

# E-GOVERNANCE AND URBAN POLICY DESIGN IN DEVELOPING COUNTRIES



**UN HABITAT**  
FOR A BETTER URBAN FUTURE





**E-GOVERNANCE**  
AND **URBAN POLICY**  
**DESIGN** IN DEVELOPING  
COUNTRIES

**E-Governance and urban policy design**

First published in Nairobi in 2015 by UN-Habitat

Copyright © United Nations Human Settlements Programme 2015

All rights reserved

United Nations Human Settlements Programme (UN-Habitat)

P.O.Box 30030, 00100 Nairobi GPO KENYA

Tel: +254-20-7623120 (Central Office)

[www.unhabitat.org](http://www.unhabitat.org)

HS Number: HS/054/15E

ISBN Number: (Volume) 978-92-1-132673-4

An electronic version of this publication is available for download from the UN-Habitat website at <http://www.unhabitat.org>

**Disclaimer**

The designations employed and the presentation of the material in this publication do not imply the expression of any opinion whatsoever on the part of the Secretariat of the United Nations concerning the legal status of any country, territory, city or area or of its authorities, or concerning the delimitation of its frontiers or boundaries. Views expressed by authors in this publication do not necessarily reflect those of the United Nations, Human Settlements Programme, the United Nations, or its Member States.

References to names of firms and commercial products and processes does not imply their endorsement by the United Nations, and a failure to mention a particular firm, commercial product or process is not a sign of disapproval.

Excerpts may be reproduced without authorisation, on condition that the source is indicated.

This project has received funding from the European Union's Seventh Framework Programme for research, technological development and demonstration under grant agreement no 287119.

**Core Team**

Project leader: Joe Hooper

Coordinator: Fabienne Perucca (UN-Habitat) and Peter Sonntagbaeur (Cellent AG)

Financial support: European Commission – 7th Framework programme

Editor: Olu Saar

Cover photos: Shutterstock

Design and Layout: Freddie Maitaria

Printing: UNON, publishing services section, Nairobi

# Contents

<b>Acknowledgements</b> .....	<b>iv</b>
<b>Introduction</b> .....	<b>1</b>
<b>PART 1: ICT - ENABLED INCLUSION AND PARTICIPATION</b> .....	<b>3</b>
a. Marginalized Groups in ICT-enabled Governance: Lessons from the Balkans.....	4
b. Audiovisual Information Centres for South-Asian Countries: Bangladesh, a Case Study .....	18
c. Dumb Phones, Smart Youth: Impact of ICT and Mobile Platforms on Youth Engagement in Local Governance .....	26
d. "City Changer Labs and Digital Civics" .....	42
e. What's after Land Tenure? From Squatter Settlements to Participative Local Governments.....	54
<b>PART 2: COLLABORATIVE URBAN POLICYMAKING</b> .....	<b>65</b>
a. Planning Support Systems as Collaborative Planning Enablers .....	66
b. GestãoUrbanaSP: The City Built on a Network Society .....	76
c. Façade Improvement through Public Participation in South Salsabil District of Tehran .....	84
d. Geographic Information Systems and Policy Coordination in a Strategic Spatial Planning Context: Problems and Possibilities.....	98
e. E-Governance and Rural-Urban Continuum: Study in Indian Context.....	110
<b>PART 3: TOOLS AND METHODOLOGIES FOR COMMUNICATION, VISUALISATION AND MONITORING</b> .....	<b>123</b>
a. Fuzzy Cognitive Maps for Urban Policy Design in Developing Countries.....	124
b. Geofencing as a Tool for Participatory Processes.....	132
c. Technology Democratizes Information and Promotes Transparency in Public Management .....	144
d. E-Participation Readiness in Developing Countries .....	154

## Acknowledgements

UN-Habitat joined the Future Policy Modeling research project (FUPOL <http://www.fupol.eu/>) as a full partner in 2013. FUPOL is a research consortium that aims to create a comprehensive information communication technology model to support public policy design and implementation. It consists of 17 partners from 9 countries and comprises multinational companies, leading research institutes, and cities. FUPOL has developed products to support the policy design and implementation lifecycle and provides a new approach to traditional politics building on major innovations (multichannel social computing, crowd sourcing, simulation).

UN-Habitat coordinated this publication to bring the developing countries and the urban policy design perspectives in this global research. This book further elaborates on ICT-enabled governance, especially in policy design, decision-making and relations with citizens and other spheres

of governments in growing urban areas. This publication is the fruit of contribution of various individuals and institutions involved in ICT, e-governance and urban policy design.

The work was initiated and supervised by Joe Hooper, the Urban Legislation, Land & Governance Branch coordinator, and coordinated by Fabienne Perucca, Local Government and Decentralisation Unit. It received continuous support from the FUPOL coordinator, Peter Sonntagbaeur and partners. We thank the chapters' authors for their direct and valuable contribution to this book.

This publication was made possible thanks to the support of the European Union Seventh Framework Programme for research, technological development and demonstration.

## Introduction

The purpose of this book is to illustrate the synergies, contradictions and potentials that are emerging through the intersection and interplay of three global trends: urbanisation, the near ubiquity of information communication technologies, and the increasing role of local governments.

The world is predominantly urban. 10 per cent of the world's population lived in urban areas at the beginning of the 20th century. By 2012, 50 per cent of the global population lived in urban areas, and by 2030 this is forecasted to rise to 60 per cent. Today's 3.6 billion urban dwellers are distributed unevenly among urban settlements of different sizes, and more than 7 of every 10 urban residents in the world are found in developing countries. Over the coming decades, the level of urbanisation is expected to increase in all major areas of the developing world, with Africa and Asia urbanising more rapidly than the rest. Urbanisation can be a powerful and positive force for development, if urbanisation is planned for in advance, and well managed and governed. However not all citizens have benefitted equally from what urbanisation can bring. Cities and towns in developing countries are facing serious challenges including: unemployment, especially among the youth, high percentage of people living in slums, inadequate urban basic services, unplanned peri-urban expansion, and high level of vulnerability to natural disaster, among others.

Powers are increasingly local and they evolve in a more complex environment. Local and regional governments are increasingly being recognized as essential actors for the achievement of sustainable development. They have the proximity and scale, being the closest sphere of government and often the first gate for people's participation in public affairs. In many countries of the world, they also have the legitimacy of being directly elected by their citizens. The size of cities and their growth, their social and spatial divides, their economic characteristics and institutional dimensions bring unanticipated dimensions of governance. Local governments have the proximity to translate the principles of good urban governance to effectively manage, govern and develop a city and to ensure equitable access to citizenship. Local capacities are also at stake to be able to address the local needs. The new complexities of cities of today require a constant and fluid dialogue between institutions, on the one side, and between people and institutions, on the other. The extent and the tools with which city governments are able to implement and deliver decisions within a complex urban environment are key.

Information and Communication Technologies (ICT) are increasingly affordable and near ubiquitous. One third of the world's population was online in 2011 and 62 per cent of users were in developing countries. ICT is transforming the way governance takes place. Mobile phones have become the most ubiquitous form of modern ICTs and the developing world now is "more mobile" than the developed world. Of the nearly seven billion mobile-cellular subscriptions, penetration will reach 96% worldwide and 90% in the developing world by the end of 2014<sup>1</sup>. Developing countries are home to more than three quarters of all mobile-cellular subscriptions (78%), where penetration continues to grow at twice the rate as in

developed countries (3.1% compared with 1.5%, respectively). Broadband and narrowband mobile communications applications are tailored for users in developing countries. The question is not so much one of access but also one of usage and the digital divide. The use of mobile phones use has permitted a larger number of citizens to increase the access to benefits of broadband internet. Mobile phones are rapidly gaining new capabilities, evolving from a simple voice device to a full-fledged multimedia tool for social networking, banking, news consumption, organising, entertainment, and in the public domain, public services<sup>2</sup>. Thanks to the innovative thinking of citizens and public officials, ICT has become a tool that has improved the inclusiveness and responsiveness of many public policies at the local level and also to improve service delivery in many municipalities and countries.

Governance is about the processes by which public policy decisions are made and implemented. It encompasses the constellation of relationships between a wide range of stakeholders. ICT enabled -governance is understood as the facilitation of governance processes by electronic tools and ICT devices (mobiles, internet, social media, interactive programmes, etc.). UN-Habitat believes that ICT can become a catalyst to improve governance in towns and cities and help increase the levels of participation, efficiency and accountability in public urban policies, provided that the tools are appropriately used, accessible and affordable.

This book examines how ICT enabled governance is applied to urban policy design. The book is divided into three parts, reflecting the various usage and questions at stake: The first part "ICT-enabled inclusion and participation" explores the citizens and governments understanding and use of ICT, particularly for inclusiveness purpose (youth, marginalized, illiterate, urban poor). The second part "Collaborative urban policymaking" gathers case studies exemplifying the bottom-up and horizontal relations that become possible and increase citizen engagement in planning processes. The third part "Tools and methodologies for communication, visualisation and monitoring" presents some specific approaches to further enable good governance in urban policy design.

The book includes contribution from Albania, Austria, Bangladesh, Brazil, India, Iran, Israel, Italy, Japan, Germany, Greece, Mexico, Oman, Peru, South Africa and the USA. The contributions portray efforts made by policymakers, researchers, community organisations, local and central governments to support urban policy design and implementation via ICT-based mechanisms. This book highlights case studies, tools, methodologies, all reflecting current challenges and potential for the use of ICT in governance processes in cities. It celebrates the work that community-based organisations and local governments are doing on the ground. Not all projects and initiatives are fully completed and there are many other applications of ICT in urban policymaking (municipal finance, service monitoring, etc.) not all reflected. As such this book does not purport to be exhaustive, but rather to show the diversity of application of ICT in urban governance dynamics and how ICT-enabled governance can revitalize the vertical, horizontal and polycentric relations between governments, citizens, non-state actors and private sector.

## Endnotes

1. The World in 2014: ICT Facts and Figures, International Telecommunication Union 2014
2. Youth, ICT and governance, UN-Habitat 2015.



# 1

Part

## ICT-ENABLED INCLUSION AND PARTICIPATION



Diverse People Digital Devices Wireless Communication Concept  
© Shutterstock/Rawpixel



# Marginalized Groups in ICT-enabled Governance: Lessons from the Balkans

- ◉ John Driscoll  
Institute for International Urban Development, Cambridge MA, USA
- ◉ Maren Larsen  
Institute for International Urban Development, Cambridge MA, USA
- ◉ Dritan Shutina  
Co-PLAN, Institute for Habitat Development, Tirana, Albania
- ◉ Aida Ciro  
Co-PLAN, Institute for Habitat Development, Tirana, Albania

## Abstract

Building on original research on social sustainability in several Balkan cities under a World Bank-Austria Urban Partnership Programme, the following chapter seeks to identify the barriers facing marginalized populations to engage fully with e-governance mechanisms, and explore ways in which the cities of Skopje, Banja Luka, Durrës, Prishtina, and Sarajevo have formulated strategies to include society's most vulnerable in socially accountable policy formulation and governance. It also presents lessons drawn from the

application of a conceptual framework that views social accountability as a means to achieve social inclusion through a governance dialogue among citizens, local government, and intermediaries, whose relationships and interactions can be enhanced by participation, transparency, as well as feedback and monitoring. Findings outline the need for greater flexibility and targeting to increase participation of vulnerable groups, while simultaneously increasing the transparency and strength of communication feedback loops.

## Keywords:

Vulnerable groups, social accountability, transparency, Balkans

## Introduction

E-governance and the contribution of rapidly advancing technologies have increasingly taken centre stage in the promotion of good governance. Unlike other public reforms that seek to increase internal efficiency and, therefore, focus almost strictly on increasing government's capacity to deliver services, e-governance and the combination of data analysis and citizen input platforms has the potential to transform the very nature of the relationship between citizens and their governments (Saxena, 2005). This transformation is happening at a time of increasing urbanization, which puts pressure on local authorities to manage urban development and provide sufficient and equitable access to services for marginalized communities within the formal and informal city, as well as access to opportunities to engage in civic life and participate in decision-making. These challenges can in turn compromise a municipality's ability to govern in an efficient and transparent way.

According to the United Nations Development Programme, good governance principles can be summarized into three pillars: participation and inclusion; non-discrimination and equality; and rule of law and accountability (UNDP, 2011). The research presented here focused on the first and last of these principles, namely the inclusion of vulnerable or marginalized groups in service delivery (including ICT-enabled services) and the social accountability and sustainability of such practices. This paper draws upon work carried out by the authors and local study teams in five Balkan cities from 2012 to 2013: Sarajevo and Banja Luka (Bosnia and Herzegovina), Skopje (former Yugoslav Republic of Macedonia), Prishtina (Kosovo), and Durrës (Albania). The project was undertaken as part of the World Bank's Europe and Central Asia (ECA) Sustainable Cities Initiative, and the World Bank and Austria Urban Partnership Programme (UPP) for Strengthening Local Governments in South-Eastern Europe. The project was funded by the UPP and managed by the ECA departments for social and for urban development, and the World Bank Institute (*The analysis, results, and views expressed in this paper are those of the authors alone and do not represent the position of the World Bank or any of its member countries. The authors would like to acknowledge the important contribution of the World Bank team in framing this pilot project on social accountability including Sabine Palmreuther, Nicolas Perrin, and Sandra Schlossar.*)

Several local governments in the Balkans have integrated aspects of e-governance into their operations, ranging from basic websites to sophisticated, interactive online platforms and even branded systems. The existence of such platforms, however, does not automatically translate into greater efficiency or greater social accountability. In fact, documentation of case studies in different regions shows that it is rare for the introduction of information and communications technology to produce any dramatic changes in accountability on its own (Fung, Gilman, & Shkabatur, 2010). While local authorities in several Eastern European cities have taken the first steps of implementing e-governance mechanisms to meet growing demand for accountable governance and policymaking, findings from the social sustainability assessment highlight diverse challenges to enhancing the quality and effectiveness of the supply. Some of the problems encountered by citizens and local authorities undertaking the audit included poorly functioning and out-

of-date municipal websites and information that is deemed irrelevant to the enhancement of service provision and quality of life. In addition to outlining the challenges of ICT-enabled governance and proposals for overcoming them, this paper will describe the methodology used to identify such challenges, as well as the approach to developing solutions formulated by local stakeholders to improve upon the existing e-infrastructure and enhance its contribution to participatory policy practices and quality service delivery.

Some of the challenges encountered by citizens and local governments in this project are the result of local political histories, economic transitions and social fabrics. Many of the shortcomings of current e-governance and social accountability mechanisms, however, are the result of much larger and widely applicable situations facing local governments, including the suburbanization of poverty through the emergence of informal settlements, deteriorating infrastructure, financial constraints, post-conflict reconstruction issues, and unequal or incomplete decentralization processes. Marginalized populations are often hit the hardest and as municipal challenges accrue, so too do their disadvantages brought on by spatial segregation, informality, unequal service provision and unemployment.

The opportunities of these platforms and processes to hold governments accountable to their most vulnerable citizens, as identified by local stakeholders, bear lessons for other local government units and citizen groups concerned with effectively increasing participation, transparency, and communication in citizen-government relations. In addition to the recommendations one can propose based on this project experience, the manner in which the assessment framework allows all stakeholders to reflect critically on the progress and setbacks of e-governance and formulate targeted solutions to redress shortcomings equally provides insights on the methodological considerations of assessing social accountability mechanisms.

These dual objectives of reflecting on the project process and sharing lessons from the project findings will be achieved by providing a brief description of the overall context in which the social audit took place. The main focus of the paper will centre on the development of the social accountability framework and its application for assessing how municipalities respond to and include vulnerable groups. The findings in each of the five Balkan cities will be analysed before presenting the proposals formulated to attend to identified weaknesses in e-governance. Since the implementation of these participative proposals is at various stages across the five cities, other cases that highlight points made in the proposals will also be used to demonstrate some of the best practices emerging in the region. The discussion of findings will conclude with potential directions in which this work can be taken and concrete lessons from the experience that can be integrated into other local governments' reflections and implementation of inclusive e-governance mechanisms.

## The Context for Social Sustainability Auditing

The findings and theoretical framework proposed here for thinking about inclusive e-governance are the result of a participatory assessment of social accountability in service provision undertaken by the authors in Banja Luka (Bosnia and Herzegovina), Durrës (Albania), Prishtina (Kosovo), Sarajevo (Bosnia and Herzegovina), and Skopje (former Yugoslav Republic of Macedonia). The assessment sought to identify existing social accountability practices, evaluate them, and work with a wide variety of stakeholders to draft proposals that incrementally enhance effectiveness and inclusivity of various mechanisms. Emphasis was placed on identifying trends across aspects of social accountability within each city, rather than engaging in a comparative exercise across cities.

Through social sustainability audits conducted in the above mentioned cities, the authors and stakeholders developed a framework for analysis and formulated people-led solutions to enhancing the accountability of municipal authorities. The project included a specific focus on proactively tackling the challenges faced by marginalized groups through the identification of their needs and associated inequalities. Information and communications technologies and related e-governance initiatives, therefore, are viewed as mechanisms for social accountability in this framework.

Social accountability is critical to the urban policy life cycle to ensure that policies adhere to the principles of good governance. Participatory and transparent processes with built-in feedback mechanisms encourage the formulation of policies and initiatives that better respond to citizens' needs by providing an open and interactive platform through which they can affect governance. Provisions for the inclusion of vulnerable and marginalized communities, as this paper seeks to demonstrate, should be explicitly integrated into and alongside mechanisms of accountability in order to produce more socially sustainable policy outputs.

Drawing on existing literature and the social sustainability audit process, the authors and other members of the study team developed the framework illustrated in figure 1 to capture the pillars of social accountability and the relationships at the core of various mechanisms, including those enabled by ICT. The framework centres on the relationship between citizens and local authorities but also acknowledges the important role of civil society bodies and non-governmental organizations, higher education institutions, and other intermediaries in facilitating dialogue between people and government and enhancing the relationship. The pillars of participation; transparency; and feedback and monitoring represent the dimensions used to develop social accountability indexes for each city in the audit, and informed the work of participatory scenario workshops to attend to the weaknesses revealed by the audit. Participation can be further broken down into two subcomponents: (1) engagement of citizens in civic life through various initiatives (current demand); and (2) opportunities available to citizens to participate (potential demand). Similarly, the transparency pillar is composed of two dimensions: (1) information availability – the disclosure of local government

information and decisions; and (2) information accessibility – the utility and ability to use this open data information productively. The organization and subcomponents of these pillars allow those interested in undertaking a social accountability audit to assess the availability of mechanisms and the ability of people to use them.

The third pillar, feedback and monitoring, is critical and deserves equal consideration in e-governance mechanisms to enhance social accountability. Feedback and monitoring is the dimension concerned with ensuring effective two-way communication between elected officials, municipal administrations and residents. Participation of citizens and transparency of local governments is less meaningful if responsiveness and dialogue between the concerned parties are not fostered in a sustainable way.

Figure 1. Framework for Social Accountability

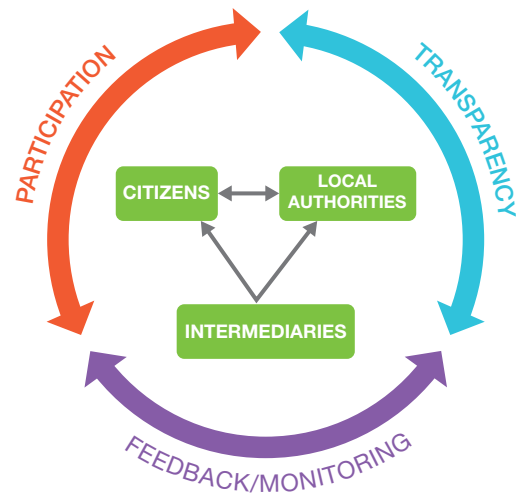

Parallel to the development of this three-part framework for ensuring social accountability, the study team worked with local city teams to compile city profiles based on available data, so as to understand the context in which social accountability mechanisms operate and to identify vulnerable segments within the population. The broad categories of vulnerable populations identified across the five cities through the city profiles included: youth, the disabled, the elderly, ethnic minorities, Roma communities, and women. Nearly all groups identified experience high rates of unemployment and poverty, contributing to the determination of their vulnerability. Definitions for certain categories differ across Bosnia and Herzegovina, Albania, Kosovo, and the former Yugoslav Republic of Macedonia, as well as the extent of their marginalization in different cities. These city profiles include those who are legally recognized as vulnerable as well as those who are vulnerable in practice. Despite minor differences among the five cities owing to historical and political contexts, vulnerability, although category-specific, was difficult to confine to particular parts of the city.



Using focus group discussions with members of the identified marginalized groups and in-depth interviews with representatives from the private sector, local government, and civil society organizations, the study team and local partners were able to obtain diverse perceptions of accountability levels and practices, and gauge the use and availability of information and communication technologies. The information gathered through these focus groups and interviews enabled the study team to complete social accountability indices for each of the five cities. It also partly dealt with the issue of non-existent or inconsistent data at the municipal and local level. Each index was composed of the five dimensions of the framework and each dimension had a score value based on “yes” or “no” responses to a set of five questions (the maximum possible score being five). The simplicity of the index allows comparison of cities with a common history and some shared characteristics. It is not meant to measure cities’ accountability practices against an ideal, but rather allows for local tailoring to make it a flexible and useful tool for multiple stakeholders within a single municipality. The findings for Banja Luka, Durrës, Prishtina, Skopje and Sarajevo are presented below, as well as the five-city index average. (A detailed copy of the index questions and rationale is presented in Annex 1.)

Figure 2. Results of Social Sustainability Audit  
(See Annex 1 for details on scoring)

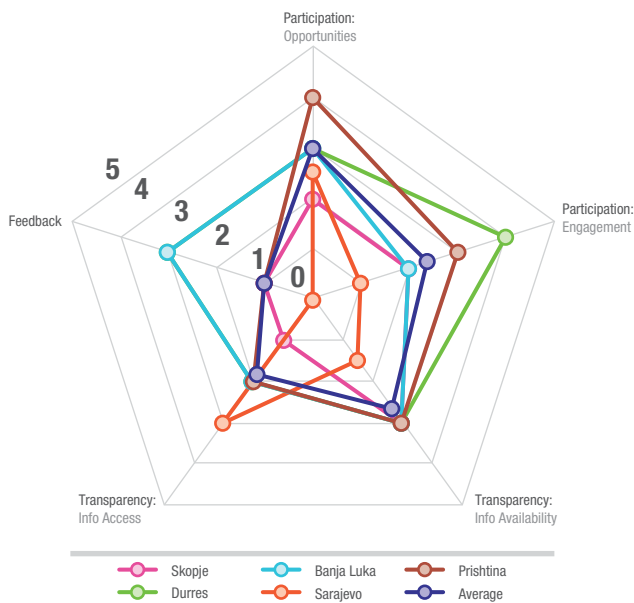

SOCIAL ACCOUNTABILITY IS CRITICAL TO THE URBAN POLICY LIFE CYCLE TO ENSURE THAT POLICIES ADHERE TO THE PRINCIPLES OF GOOD GOVERNANCE.



### ICT-enabled Accountability Challenges in Balkan Cities

As visualized in figure 2, feedback and monitoring is the weakest pillar of social accountability in these cities. It is clear from the index that opportunities for citizen input and participation exist to varying extents and that local governments are relatively transparent in their publishing of municipal information. Limited “one-size-fits-all” channels of communication for citizens to express their needs and for relevant local authorities to respond are, however, impeding greater gains in social accountability and the application of ICT in different e-governance tools. Grievance redress mechanisms were closely examined to assess the level of feedback in municipal accountability efforts including determining the existence of such mechanisms and their effectiveness, usually dependant on a reasonable response time and use of complementary technologies to broaden communication engagement opportunities. Banja Luka and Prishtina – two cities that have integrated such mechanisms – had time limits for grievance responses that were generally abided by, though neither used multiple technologies nor tracking systems. In Banja Luka, legislative provisions in both jurisdictions required government authorities and institutions to provide official responses to submitted complaints within 30 days. In practice, however, citizens reported that responses were often delayed or incomplete and the information technology tools implemented for feedback were not seen as mechanisms for collaboration. In Banja Luka and Prishtina, these mechanisms were largely underused by citizens and institutions. Past neglect of citizen grievances have fomented distrust between citizens and local governments, leading citizens to approach newer, more complicated ICT-enabled tools with skepticism.

Another explanation of the low average score of feedback and monitoring in the assessment is the ad hoc nature of regular evaluations of service provision through satisfaction surveys. Monitoring and performance measurement of municipal service provision did not appear to constitute a regular practice per se; rather it was an ad hoc process required by specific projects in which the municipality was involved. Such was the case in Durrës. Businesses or citizens, or both, would be surveyed on a project basis or, alternatively, through various non-governmental organizations actively operating in the city. One exception to ad hoc monitoring and evaluation is the annual citizen satisfaction survey administered in Banja Luka by the city’s Department of Public Utilities, Housing and Traffic.

The second lowest scoring category of assessment, on average, was the information accessibility dimension of transparency. All cities except Sarajevo scored higher on information availability than on accessibility, identifying a key area in which to make interventions to improve transparency and overall accountability practices. One of the underlying assumptions of ICT-enabled governance is that platforms are accessible and that the devices to access such platforms are useable by citizens. When looking at e-governance, particularly as it pertains to vulnerable groups, these city assessments demonstrate that it is not enough to make information available; citizens must know how to access and use the ICT platforms and devices. Banja Luka has an exemplary practice of centralizing information distribution in the Public Relations Department, in addition to producing a guide on how to access municipal information available on the city website. Low information accessibility is likely linked to ineffective or non-existent communication or feedback mechanisms, which fail to promote where and how citizens can access different services and documents. The nature of the content made available and ways of engaging may also influence accessibility. For example, in the case of Prishtina or Durrës, although the municipality has a website, it did not meet desired levels of city-citizen communication and was seen to be further marginalizing groups by failing to respond to their needs through diversified and user-friendly systems. Although all municipalities in the audit have opted for developing an almost one-way online presence (website) for many years now, by underestimating the importance of feedback and monitoring mechanisms, they have failed to capture the potential of such ICT tools to improve accountability through the added communication value as opposed to existing analog practices. This has caused citizen distrust.

Several challenges to building social accountability into governance in Balkan cities, while not directly captured in the index results, were revealed through focus group discussions, documentation of institutional and legal frameworks, and interviews with local officials. One of the overarching issues hindering progress, acknowledged by citizens and local officials, is related to the decentralization of responsibilities to different levels of government. Unequal and incomplete decentralization processes have led to confusion over domains of competency belonging to local governments or the shirking of responsibility to other levels of government. This creates several bottlenecks in the accountability of service provision which has, in some cases, engendered informal interventions to improve the situation.

Several of the municipalities in the study have smaller, local administrative units that are reportedly not functioning in a way that connects citizens to central city administrations or are inadequately implementing participation, transparency and feedback mechanisms to enhance accountability. In Bosnia and Herzegovina, these units are regarded as the closest to citizens, yet suffer from insufficient administrative and financial support, residential unfamiliarity or disinterest in their activities, lack of professional staff, and council member passivity hindering their ability to function efficiently (Galic & Predojevic, 2013). The two administrative units governing the capital – Sarajevo and East Sarajevo – further complicate the situation in a city whose local governance structure is divided between the Sarajevo Canton, the City of Sarajevo, and four mjesne zajednice (local municipalities) (Demir & Mehmedbašić, 2013). Energizing these local councils was seen as a potential means of including vulnerable groups in decision-making and community consultations, as they are seen as



Focus group discussion in Skopje (FYROM). © KOR Coalition for Sustainable Development for I2UD and Co-PLAN.



MANY SPEAK OF THE “DIGITAL DIVIDE” IN TERMS OF INTERNET ACCESS, BUT IT IS IMPORTANT TO REMEMBER THAT WHEN IT COMES TO PARTICIPATION AND COMMUNICATION WITH LOCAL GOVERNMENTS, VULNERABLE GROUPS EXPERIENCE OTHER TYPES OF DIVIDES CAUSED BY INCONVENIENT OFFICE HOURS, TIME-CONSUMING PROCESSES, OR LANGUAGE BARRIERS, WHICH DISCOURAGE THEIR CIVIC PARTICIPATION.



one of the most effective mechanisms through which to garner social accountability. Banja Luka proactively dealt with this issue through short-term project activities aimed at capacity-building for council members and interested citizens. Additionally, citizens are often unaware of the roles and functions of these local administrative units or do not know how to go about engaging them.

### :: Vulnerable Groups

Building inclusivity into governance, and particularly e-governance, first requires an identification of the excluded, or vulnerable groups. Identifying these groups and understanding their socio-economic, legal, demographic, and spatial situations and limitations is critical to developing ways of overcoming the barriers of access to the information and participation opportunities necessary to make e-governance work for vulnerable groups.

Focus group discussions, carried out in each city with participants belonging to one or more of the vulnerable groups mentioned earlier, revealed valuable insights into how communities become marginalized and how e-governance mechanisms can incorporate socially inclusive practices into their strategies and objectives. Marginalized groups are most susceptible to low-quality services due to issues such as informal settlement patterns for Roma communities, physical inaccessibility for the elderly and overall lower disposable incomes with which to access quality basic services. In the Western Balkan countries, a significant proportion of the population can be defined as “marginalized” in one way or another. Youth populations in the South-Eastern Europe region, for example, experienced rates of unemployment in 2013 averaging 49 per cent, with rates reaching 55.3 per cent in Kosovo and 62.8 per cent in Bosnia and Herzegovina (The World Bank, 2014). Furthermore, mapping efforts in each city shed light on the difficulty of spatially representing different groups, other than those living in informal settlements. Targeting vulnerable communities with location-based interventions may not, in fact, be as effective as more municipal-wide initiatives. Marginalized citizens are scattered throughout the municipality and

live in different housing and settlement typologies in urbanized areas and emerging settlements in suburban as well as peripheral locations. Improving service delivery and accountability for vulnerable groups in the Balkans, therefore, is about improving the lives of large segments of citywide populations in formal and informal areas.

As far as existing e-governance mechanisms are concerned, marginalized groups are, to varying degrees, locked in a cycle of social exclusion that hinders their participation in social accountability processes. If an administration has failed to foster participation and transparency, and neglected to establish feedback mechanisms to create a relationship with citizens prior to the introduction of ICT tools, e-governance has proved unable to build that relationship from scratch. This is especially so with vulnerable populations who, given their circumstantial limitations, are late adopters of such tools. Many speak of the “digital divide” in terms of Internet access, but it is important to remember that when it comes to participation and communication with local governments, vulnerable groups experience other types of divides caused by inconvenient office hours, time-consuming processes, or language barriers, which discourage their civic participation. Technological constraints can work to further exclude those with already low levels of engagement in local governance. Yet other dimensions of e-governance can equally be leveraged by local authorities in a tailored way to alleviate some of the political marginalization of these groups, as many of the city proposals demonstrate.

Findings from the assessment also highlight the need to reformulate thinking about the digital divide as a “demand side” problem exclusively. The digital divide understood in this context as the inability to access or use information technology efficiently for increased social accountability is a demand (citizen) and supply (city government) issue. Balkan cities have adopted ICT tools presented on municipal websites aimed at providing information, services or communication with citizens, though not all their functionalities are operational or regularly updated. Lack of information and knowledge exists on both sides as local governments often have the capacity to index information but not necessarily process it. Increased capacity can add value to these ICT systems, particularly in shortening the distance between local government and citizens. In Skopje, the assessment revealed that staff is not adequately trained to respond to the demands of the citizens despite the existence of ICT systems. Information and participation providers need to be better informed, educated and trained while the service users need to be better informed about their rights and ways of engaging with ICT-platforms and local authorities.

### Scenario Workshops and Multi-stakeholder Proposals

Upon assessing the various cities’ levels of participation, transparency and feedback, as well as identifying and gathering qualitative information from vulnerable groups, the project moved to leverage the results of the audit for actionable change. Participatory scenario development workshops were held in each city to bring together different stakeholders from local government institutions and civil society, including marginalized citizen representatives. The goal of these workshops, which all took on their own theme based on the

outputs of the audit, was to discuss appropriate social accountability mechanisms and how they could be integrated into each city's existing systems and processes. Because the audit had already done much of the work of identifying problems, the methodology of the workshops focused on developing solutions. To do this, participants were given problem and solution cards, informed by results and findings of the audit, as a starting point for elaborating agreeable and realistic scenarios. Different tools to amplify citizen voices, enhance administrations' capacity to respond to needs, and strengthen communication channels in the citizen-government relationship were proposed to tackle the development challenges in each city. Figure 3 below summarizes the proposals that came out of the different workshops.

Some of the overarching themes in these proposals include greater incorporation of intermediaries, a key actor at the centre of the social accountability framework; enhanced responsiveness of local authorities to increase participation and transparency; and specific accountability mechanisms oriented towards marginalized or informal users.

Associations of citizens and other issue specific community-based and non-governmental organizations represent an important mechanism for including vulnerable and minority groups in urban decision- and policymaking. These organizations can provide important legal and policy information to their members and directly represent their interests in governmental working groups or committees, fostering a more productive citizen-government relationship and dialogue. They also tend to have greater institutional memories than city governments and can provide consistency in social accountability and inclusion work across changing administrations and election cycles. For example, citizen associations have proven their importance within the Sarajevo Canton Government, as people with disabilities and Roma see their associations as sources of information about their rights and how to exercise them.

In cities where focus group participants felt underrepresented in city decision-making, non-governmental and community-based organizations could begin to fill that void by voicing the concerns and interests of marginalized groups in an organized way with which local governments could more easily interact and understand. Findings from the audit show that while several non-governmental and community-

based organizations already exist to represent marginalized populations, challenges arise in their ability to provide the critical link for citizens to the municipality. One of the concerns raised by residents in certain cities was the management of these associations, claiming issues such as the promotion of personal objectives over group interests and the mismanagement of funds. One way of overcoming this concern could be for the neglected local administrative units mentioned earlier to begin to function as intermediaries between citizens and broader urban governments, and become a target of investments for better vertical communication and dissemination. Skopje expressed interest in pursuing this strategy, including the revitalization and involvement of urban communities and homeowner associations.

Stronger reliance on (and integration of) intermediaries in the actionable framework for enhancing social accountability has been advocated for, within the pillar of feedback and monitoring. Enhancement of internal feedback and monitoring systems is the most important step municipalities ought to initiate in relation to the responsiveness to citizens' requests and complaints. It can also catalyze the real involvement of citizens in the strategic planning process, rather than procedural participation, if citizens know that their voices will be heard and have the potential to be acted upon. Efficient feedback and performance monitoring mechanisms can, therefore, bring about improvement in the functioning of participation and transparency mechanisms to increase social accountability. Having a third-party group manage an ICT-enabled monitoring platform can lead to better maintenance and promotion of these critical feedback practices. For enhanced inclusion, such intermediaries should also be capable of implementing alternative, low-tech interventions to improve social accountability.

Complementary, low-tech interfaces are critical to building participation opportunities and information channels in relation to marginalized communities (Morgan, 2013). One of the primary takeaways from the social sustainability audit was that when it comes to social accountability and ICT-enabled tools, one size does not fit all. Different communication conduits are necessary to reach diverse groups of vulnerable citizens. For example, the elderly and disabled often reported difficulties accessing decision makers. Youth on the other hand, are particularly passive and untrusting in the decision-making process. With an emphasis

Figure 3. Social Accountability Proposals

	BANJA LUKA	PRISHTINA	SARAJEVO	DURRËS	SKOPJE
Enhance Participation	Web and SMS platform for monitoring transport services for vulnerable groups	Upgrade City Website	Information Centre on governance structures, rights, obligations and services.	Incorporating Social Accountability in the City Development Strategy	Citizen Database
Increase Transparency	Information Desks on employment opportunities	Citizen Charter and Calendar of activities	Local Community Councils Revitalization	Participatory Budget	Representation for Disability groups
Strengthen Feedback and Monitoring	Upgrade City Website	Monitoring as part of City Modus Operandi	Public Fund for Social Entrepreneurship	Upgrade City Website	48-hr response requirement for citizen queries

Source: (I2UD & Co-PLAN, 2013)



on tools that cater to vulnerable communities at their different levels of civil engagement, cities participating in the audit proposed such mechanisms as Web-SMS monitoring of public transport to increase accessibility for the disabled in Banja Luka and linking up with middle and high schools to promote civics and active volunteerism in Skopje.

Prior to the scenario development activities that produced proposals like those mentioned for Banja Luka and Skopje, participants heard presentations about the use of ICT for increased social accountability and learned about different ways in which ICT has been used in other countries in the region to increase participation and transparency. This occurred through case study presentations with the goal of building capacity amongst stakeholders to understand the potential role of ICT in improving social accountability. One of cases in which participants took particular interest was System 48 developed in Indjija, Serbia, and implemented in Indjija as well as Strumica, Macedonia. This management system is unique in South-Eastern Europe as it tackles the feedback and monitoring pillar of accountability in an effective way while improving the internal efficiency of local authorities to coordinate their responses. System 48 institutes a two-day requirement for an institutional response to citizen grievances (Bodirožić, 2013). The system promotes better management practices at the urban administrative and institutional level, and successfully integrates regular performance reviews and monitoring of services.

Another type of best practice that has emerged since the end of the study and deals with the pervasive, region-wide issue of disconnected relationships between citizens and local authorities and weak or inefficient feedback and monitoring mechanism is the Slovakian platform “Odkaz Pre Starostu” (Message to the Mayor). Inspired by the United Kingdom’s platform “Fix My Street”, the platform is administered by an intermediary, non-partisan civil society organization (Inštitút pre dobre spravovanú spoločnosť – Slovak Governance Institute). Photographs of problems, citizen descriptions, and localization within cities are formulated into complaints, organized on the platform, and channeled to the responsible municipal entity to take action. Citizens receive confirmation upon receipt of their complaint through the dispatching system and the complaint becomes visible to others on the platform. Citizens can follow the complaint on the portal through status labeling, which indicates whether the complaint has been submitted, checked, settled, or decided on by other means. Periodically, issues that go unresolved are removed from the portal and the administrators from the Slovak Governance Institute organize groups of volunteers to repair playgrounds, collect garbage, plant flowers, and solve other unresolved issues. A chart of the resolved and unresolved citizen submissions in the capital city Bratislava as of May 2015 is presented in figure 4 below. Message to the Mayor is active in 15 Slovak towns and villages, representing 31 municipalities.

Figure 4: Number of Resolved and Unresolved Submissions by Responsible Entities in Bratislava (Source: Slovak Governance Institute, 2014)

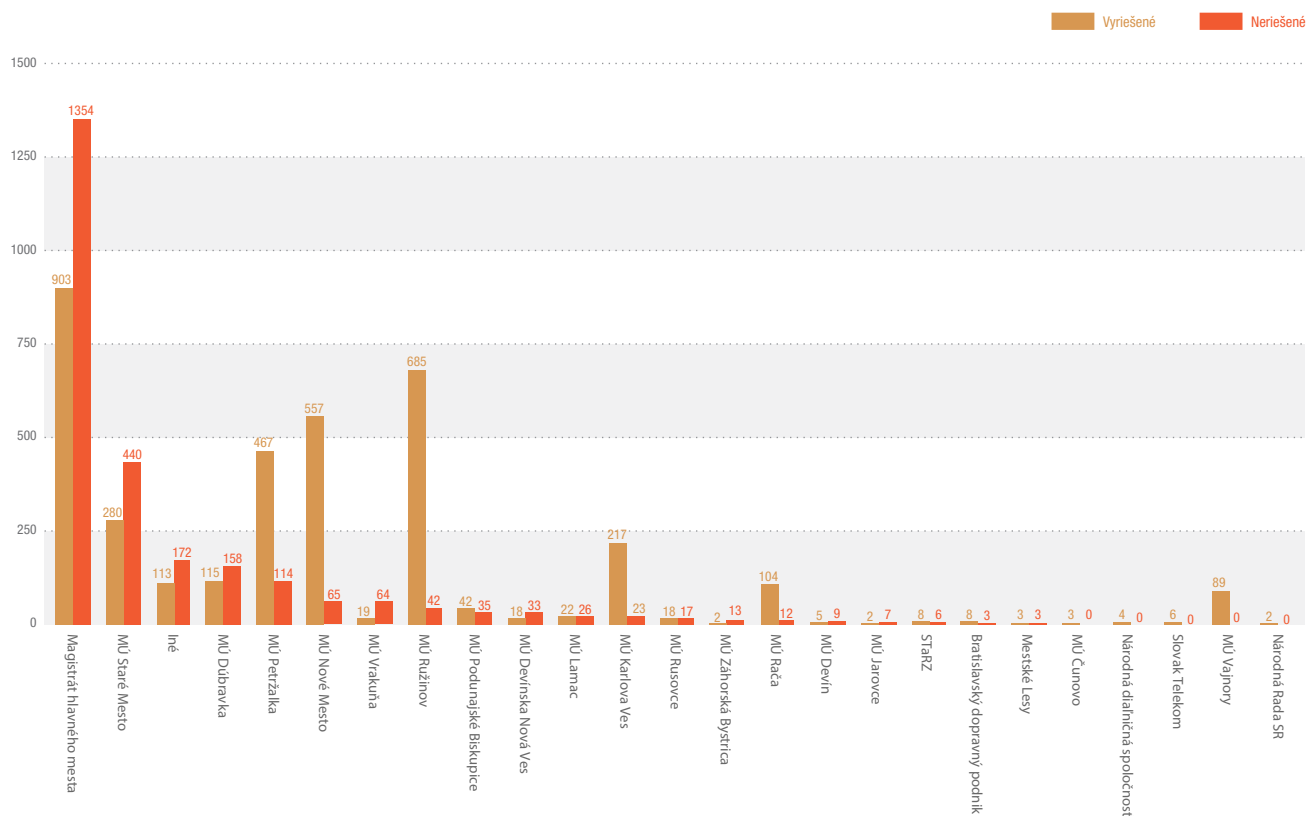

(Brown represents “resolved” and orange “unresolved”)

The mediating role played by the administrator of the platform strengthens the citizen-government service relationship through the creation of a productive and unbiased space for citizens to make demands and for local authorities to respond by the best available means. The user-friendly website and its mobile applications have facilitated participation to the extent that local authorities throughout Slovakia can no longer afford to ignore complaints filed through the platform. Municipal authorities in Slovakia now unofficially compete to respond to most citizen demands and the positive reinforcement of a culture of accountability in citizen-government relationships has been embedded by the process. The platform administrators have also held events targeting the youth population through presentations in schools and an activity for high school students to identify the problems in their city. This sort of explicit engagement in schools to ensure inclusion and mediation by a civil society organization can be highlighted as a best practice of social accountability in e-governance.

## Adopting Solutions and Transferring the Methodology

The proposals for improving social accountability in each of the five cases were jointly developed by participants from civil society organizations and the municipalities. This in itself was viewed as an important accomplishment by the participants, who were enthusiastic about bringing social accountability practices to their cities. Intended as a pilot, the social sustainability audits carried out in these Balkan cities demonstrated a methodology that can be adapted and transferred to assess accountability practices and the effective use of ICT in delivering services and formulating policy in other localities and sectors. Local authorities could, for example, use the process to undertake a self-assessment to obtain a snap-shot of the effectiveness of their current practices and how to attend to needed improvements.

The cities participating in this particular study considered different administrative departments to lead in social accountability activities. In Durrës for example, the Department of Development Projects took responsibility for the audit and planned to include “social accountability” as an integral part of the revised City Development Strategy, while in Prishtina the director of administration took the lead. Intermediaries, such as civil society organizations or educational institutions, can also carry out such audits with the advantage of having greater institutional memory than administrations that frequently change leadership. City administrations or independent organizations can begin to move towards action on these ideas by prioritizing proposals in alignment with existing municipal strategies and drafting business plans to secure external funding.

More theoretically, the social accountability framework developed concurrently with the project methodology has proven its utility in the determination of urban challenges, their interrelationships, and inclusive problem solving to heighten participation, increase transparency, and strengthen feedback and monitoring. The audit’s capacity to diagnose these issues and visualize findings in a way that is easy to understand for all stakeholders encourages wide participation and engagement to develop solutions. The study team believes this methodology has the

potential to be repeated in different cities and across regional contexts to reveal not only local challenges and solutions, but also broader lessons about e-governance.

This methodology, because of the focus on urban management and service delivery, can be employed by municipalities to assess the quality and level of access to services in specific neighbourhoods, larger districts or metropolitan areas. Although tailored to introduce good practices in social accountability and inclusion supported by the ICT sector, the methodology can also be used in other sectors, such as infrastructure or urban planning. In addition, the social audit can explore issues and concerns that are often not considered in traditional consultation processes. The methodology is open and solution-focused, which is helpful when considering projects that can be contentious by the nature of their intervention. The techniques employed through this methodology utilize scenario planning, a tool to improve open and informed deliberations on urban policy and management practices in a context of urbanization that brings greater uncertainty and larger numbers of stakeholders. Based on the experience, processes, and feedback received from the various parties involved in the social sustainability audit, (including local authorities, citizens, civil society, private sector and media) the following methodology is suggested and can be adapted by municipalities based on ranges of available data and capacity.

### 1) Mapping Urban Management – Service and Citizen Vulnerability

Efforts to integrate inclusive ICT into governance and policymaking can begin with a synopsis of key development challenges, opportunities, identification of existing social accountability practices, and mapping of vulnerable communities. In the audit, this exercise culminated in the formulation of the city profiles mentioned earlier, and informed the development of the index for measuring accountability practices. A brief synopsis report is important to obtain a clear, up-to-date snapshot of the context and current situation in the municipality relative to vulnerability, accountability, and the particular service sector that the local authority seeks to improve. As a result, such a report can contribute to highlighting additional interrelated fields that need improvement such as institutional organization, ICT and file-keeping/statistics. In this social sustainability audit experience, the process was conducted by two specialized non-governmental organizations - a model that should be replicated to minimize bias.

### 2) Engaging and Mobilizing the Key Interest Groups in the City

Because this methodology specifically deals with marginalized groups, the engagement of civil society organizations is crucial, as they tend to have good community outreach strategies and institutional as well as organizational memory of the issues and interests at stake. The contribution of qualitative information in the methodology, collected through focus groups and in-depth interviews with such diverse stakeholders as community representatives, municipal officials, central authorities, and members of the private sector, cannot be overstated. Originally conceived to overcome the lack of available data at the city and community levels, the organization of fieldwork in this way established relationships that were leveraged throughout the project life cycle, allowing the study team to obtain further insights and validate findings through continuous consultation. There is still critical “hard” quantitative information that needs to be considered when it is available—a challenge for municipalities where both the economy and physical development is characterized by informality. Identifying and taking stock of different institutional and legal frameworks is also important

in focusing the accountability index questions so that findings and eventual interventions can be aligned with existing strategies to better reach vulnerable communities.

### 3) Setting the Agenda for Change through Participatory Approaches

Based on the findings from the first two stages, municipalities (or third parties collaborating in the process) can employ participatory practices, in order to discuss and agree on a number of concrete steps to be undertaken in order to attend to, in part or in full, the issues raised. Participatory scenario development workshops held with all stakeholders benefited from consultations in the preliminary phases by allowing discussions to move quickly from expressing grievances to solving problems. From this scenario development exercise, action plans can begin to emerge. It is important that such action plans are time bound, measurable, and have clearly assigned ownership to them. For accountability purposes, such action plans should be made public and revisited in case of developments. If working in more than one area within a municipality or in multiple municipalities, a regional workshop can be held as a concluding activity for regional stakeholders to interact and learn from each other in the spirit of knowledge sharing.

### 4) Monitoring and Evaluation

As proposals and plans become actionable, it is important to ensure that action plans will be pursued and to exercise accountability and transparency practices in the very process of enhancing the commitment of urban managers to the social concerns and priorities of diverse stakeholders through the targeted improvement of ICT-related mechanisms.

Conducting such an audit around the pillars of social accountability provides a self-assessment that can help a municipality to launch a discussion on these issues with its partners. The assessment index may also find utility as a performance assessment and evaluation mechanism to gauge progress in the implementation of city projects where an audit has already been conducted. Undertaking the audit again in one of the participating cities could provide information for important longitudinal analyses to determine the effects of interventions on the different dimensions of accountability.

Different lessons from some of the shortcomings of ICT-enabled governance, particularly identified through this audit in feedback and monitoring, can be useful starting points for thinking about ICT in a context of policymaking across cultural and geographic boundaries. In attempts to integrate ICT into urban policymaking and implementation in developing countries, for instance, local authorities can consider some of the mechanism characteristics reviewed in the Balkans audit, such as time limits for government responses to citizen inputs and regular monitoring and evaluation of services, including policies, across the city. The time balance question and regular monitoring were key features of System 48, which contributed to its wide success, and were among the most popular proposals to enhance engagement of vulnerable populations with ICT and accountability practices.

## Conclusions

The process of working with different groups of stakeholders to identify and craft proposals to enhance municipal social accountability has provided important lessons that should be considered as other local

authorities and citizens implement their own e-governance mechanisms to enhance urban policy design and service delivery.

Balkan cities have made significant strides in the implementation of e-governance for enhanced social accountability. There remains, however, room to improve existing systems to expand their reach and utility for the most socially and economically vulnerable members of society. As shown in the analysis of findings from the social sustainability audits, the mere adoption of e-governance mechanisms does not automatically translate to enhanced citizen participation, local government transparency, and monitoring of practices and services. This is especially the case for vulnerable and informal communities that are not fully integrated into urban service delivery and are beyond the reach of e-governance seeking to improve the management of these services.

Many of the issues identified in the audit pointed at more fundamental issues with the citizen-city social contract that need to be tackled to make the supply of information more relevant and accessible, thus fostering demand and re-establishing a public dialogue. Similarly, if social inclusion is not an explicit aim of such tools and platforms, enhanced service provision and participatory decision-making can overlook vulnerable groups or, at worse, work to further marginalize them politically. Furthermore, inclusionary measures should be harmonized and aligned with existing systems and strategies to ensure better coordination and implementation of social accountability intentions.

Another lesson of this study is that closing persistent gaps requires dedicated resources to build capacity on the supply and demand side of e-governance and the continued development and implementation of complementary communication channels. The “digital divide” is as much of an issue on the demand side of governance as it is a supply-side issue. Although there are many ICT tools integrated into the municipal administrations of Skopje, Banja Luka, Sarajevo, Prishtina, and Durrës, often through institutional websites, not all cities have the technical capacity to maintain, process, and update information on these platforms properly. Thinking about the digital divide needs to be reconceptualized in terms of e-governance through an understanding that efficient social accountability is dependent on citizens having the right tools and knowledge to access information and participate in decision-making – the demand side, as well as a municipality's internal capacity to respond to and process citizen inputs – the supply side. Enhancing feedback and monitoring mechanisms will present opportunities to strengthen both sides of the exchange.

The power of information as it is leveraged for e-governance is dependent on what municipalities, citizens, or community organizations are able to do with the information and, as this socially inclusive framework posits, how it can be tailored to meet the needs of different groups. If there is one all-encompassing finding from the application of an approach that looks at ICT-enabled accountability mechanisms as they relate to vulnerable

communities, it is that “one size does not fit all”. The methodology applied to reach this conclusion finds its strength in its ability to diagnose which dimensions of social accountability pose the greatest challenges, and then formulate diverse interventions to overcome shortcomings through a participatory and inclusive engagement process. The necessity for a range of mechanisms is demonstrated in the Balkans by the several issues emanating from widespread informality. Social accountability tends to focus on the formal city and formal mechanisms, which is why it is important to ensure ways of working and communicating with vulnerable communities to deal proactively with formal and informal issues.

Many of the cities studied here are on track to increase the number of opportunities to engage citizen participation and share information with constituents. Participation opportunities and the availability of information lose their meaningfulness in relation to social accountability if they are not promoted and made widely accessible to all citizens. Developing an e-governance framework that incorporates accountability, social inclusion and sustainable practices into urban governance provides a useful starting point for municipalities. While social accountability

has proven a challenge in all five Balkan cities studied, commitment and engagement of local government, intermediaries, and citizens can create communication channels within e-governance mechanisms that guarantee participation, transparency, and feedback.



THE POWER OF INFORMATION AS IT IS LEVERAGED FOR E-GOVERNANCE IS DEPENDENT ON WHAT MUNICIPALITIES, CITIZENS, OR COMMUNITY ORGANIZATIONS ARE ABLE TO DO WITH THE INFORMATION AND, AS THIS SOCIALLY INCLUSIVE FRAMEWORK POSITS, HOW IT CAN BE TAILORED TO MEET THE NEEDS OF DIFFERENT GROUPS.’



## References

- Bodirožić, M. (2013). System 48 in Indijija, Serbia. ECA Sustainable Cities Regional Dissemination Workshop. Skopje. Retrieved 10 July 2014. Available from [http://i2ud.org/wp-content/uploads/2013/03/Indijija\\_Sistem48\\_HolidayInn\\_Skoplje.pdf](http://i2ud.org/wp-content/uploads/2013/03/Indijija_Sistem48_HolidayInn_Skoplje.pdf)
- Demir, E., & Mehmedbašić, D. (2013). Sarajevo Social Accountability City Note. ECA Sustainable Cities Regional Dissemination Workshop. Skopje. Retrieved 10 July 2014. Available from <http://i2ud.org/wp-content/uploads/2013/03/Presentation-Sarajevo.pdf>
- Fung, A., Gilman, H., & Shkabatur, J. (2010). Impact Case Studies from Middle Income and Developing Countries: New Technologies. Open Society Foundation, Transparency & Accountability Initiative, London. Retrieved 10 July 2014. Available from [http://www.transparency-initiative.org/wp-content/uploads/2011/05/impact\\_case\\_studies\\_final1.pdf](http://www.transparency-initiative.org/wp-content/uploads/2011/05/impact_case_studies_final1.pdf).
- Galic, N., & Predojević, N. (2013). Banja Luka City Note. ECA Sustainable Cities Regional Dissemination Workshop. Skopje. Retrieved 10 July 2014. Available from <http://i2ud.org/wp-content/uploads/2013/03/Banja-Luka-City-Note.pdf>
- I2UD & Co-PLAN. (2013). Final Reflections. Social Sustainability Assessment. ECA Sustainable Cities Initiative. Retrieved 27 June 2014. Available from <http://i2ud.org/wp-content/uploads/2013/10/ECA-final-project-brief.pdf>
- Morgan, C. (2013). ICTs and Social Inclusion. ECA Sustainable Cities Regional Dissemination Workshop. Skopje. Retrieved 10 July 2014. Available from <http://i2ud.org/wp-content/uploads/2013/03/ICTs-and-Social-Inclusion-cm-i2ud.pdf>
- Saxena, K. (2005). Towards excellence in e-governance. *International Journal of Public Sector Management*, 18(6), 498-513.
- Slovak Governance Institute. (2014). Statistika. Retrieved 10 July 2014. Available from Odkaz Pre Starostu: <http://www.odkazprestarostu.sk/>
- The World Bank. (2014, May 26). Youth Unemployment in South East Europe: Averting a Lost Generation. Retrieved 10 July 2014, from World Bank News: <http://www.worldbank.org/en/news/feature/2014/05/26/youth-unemployment-southeast-europe-averting-lost-generation>
- UNDP. (2011). Governance Principles, Institutional Capacity and Quality. In B. f. Policy, Towards Human Resilience: Sustaining MDG Progress in an Age of Economic Uncertainty. New York: United Nations.

## Annex 1: Social Sustainability Index

PARTICIPATION - OPPORTUNITIES	RATIONALE	YES =1 NO = 0
1. Does the city hold consultation meetings with the public?	Face-to-face interaction with city leaders was considered valuable in an environment plagued by bureaucratic blocks. These consultation meetings could be anything from open door mayor days to public hearings.	
2. Are there elected neighbourhood councils or equivalent structures?	Local Community Council, local administrative units, etc. were widely recognized as key intermediaries, yet not currently operating to meet this potential. Public election of members could make them more accountable to their constituents and lead to more efficient councils.	
3. Does the city administration present municipal budgets to neighbourhoods as part of the formal fiscal preparation cycle?	The city should have an adopted mechanism to obtain citizen input on budget allocations in relation to service provision, infrastructure and neighbourhood facilities. Making presentations to neighbourhood councils and community groups provides opportunities for gathering neighbourhood priorities that are not often possible in larger council public hearings.	
4. Are vulnerable groups consulted when devising strategic policy documents?	To determine whether marginalized groups are part of the city's decision-making process for citywide policies such as the City Development Strategy.	
5. Does the city have a programme to engage with CSOs when reaching out to vulnerable groups?	To assess the city-intermediary relationship in working to increase visibility and outreach to these groups to vulnerable groups. "City" meaning the municipality or other local authority.	
<b>Participation - Opportunities total score</b>		<b>/5</b>

PARTICIPATION - ENGAGEMENT	RATIONALE	YES =1 NO = 0
1. Are minority or vulnerable communities represented in the current city council?	Within multi-ethnic context of the ECA region, to gage the level of diversity and participation of minority community on the city council.	
2. Are NGOs actively engaged in representing the interest of vulnerable groups?	To determine whether vulnerable groups have a go-to organization to provide support as well as pursue their interests in the public arena.	
3. Are neighbourhood councils (or similar structures) effectively linking the citizens to the city (or municipality)?	To evaluate the degree to which citizens consider their interests taken into account in neighbourhood level governance/projects.	
4. Are there youth-based outreach programmes for civic engagement?	To determine the level of engagement and civic education of the youth as a strategic cohort.	
5. Is the website considered to be a reliable source of information?	To measure the effectiveness of the city's main ICT portal/communication channel.	
<b>Participation - Engagement total score</b>		<b>/5</b>

TRANSPARENCY - INFO AVAILABILITY	RATIONALE	YES =1 NO = 0
1. Are citizens given sufficient notice about upcoming city council meetings?	To determine whether city council meetings are open not only in theory but also in practice, since a common finding was that citizens cannot attend meetings because they find out about them too late.	
2. Are municipal council decisions posted online in a timely matter?	To determine whether the outcomes of council meetings are made available even to those who cannot attend.	
3. Are city budgets available online?	Budget transparency as part of open government practices.	
4. Does the municipality have an open data policy?	Meant to gage how open the municipality is to making data public from different sectoral programmes (such as schools, hospitals)	
5. Are CSOs required to have open data practices?	To determine whether there are transparency stipulations for intermediaries.	
<b>Transparency - Info Availability total score</b>		<b>/5</b>

TRANSPARENCY - INFORMATION ACCESS	RATIONALE	YES =1 NO = 0
1. Is there an active information desk available for citizen information?	Another common suggestion during the field activities: a physical information booth with helpful staff to help citizens find the information they need without having to navigate complex city administration structures.	
2. Is there a document (charter) outlining the responsibilities of both government and citizens that is publicly accessible?	Citizen charters have been a successful tool for eliminating information asymmetries and misunderstandings.	
3. Does the municipality provide support to citizens regarding access or navigation of its ICT tools?	To maximize the impact of using ICTs, citizens should be able to manage at a basic level the technology from the user end, thus addressing the digital divide.	
4. Are there ICT training opportunities for public employees?	To maximize the impact of e-government and other such tools, government employees should be able to manage at a basic level the technology.	
5. Does the city utilize the various forms of media to disseminate information?	Throughout the workshops, solutions included using the available slots in TV, radio and print media to disseminate city information. Local governments should take advantage of this possibility given that citizens embrace the media option.	
<b>Transparency - Access total score</b>		<b>/5</b>

FEEDBACK/MONITORING	RATIONALE	YES =1 NO = 0
1. Is the time limit for grievance response abided by?	The effectiveness of grievance redress mechanisms depends on a mandatory response time that is satisfactory to the users and implemented.	
2. Do grievance/ complaint systems use multiple types of technology?	ICTs can be very valuable in extending engagement opportunities, but there need to be a set of options to accommodate the varying levels of technology access among groups.	
3. Is there a system for tracking the responsiveness to grievances of various departments/service providers?	To determine whether the departments responsible for redress mechanisms are functioning effectively.	
4. Is there an annual citizen service satisfaction survey?	Regular evaluations of citywide or specific department's functioning in terms of service provision.	
5. Is the city website updated regularly?	To determine whether the city website can be part of a fluid communication system, information needs to be kept relevant, especially the Frequently Asked Questions section.	
<b>Feedback/Monitoring total score</b>		<b>/5</b>





# **Audiovisual Information Centres for South-Asian Countries:** Bangladesh, a Case Study

- **Tanzia Islam**  
Technical University of Berlin, Germany
- **Sahjabin Kabir**  
Harvard University, USA

## **Abstract**

This paper deals with the issues of illiteracy in Bangladesh and its effects on e-governance. The application of e-governance to the lower income group has not been taken into account previously, as e-governance normally is not discussed in the context of people living below the poverty line. The paper shows that e-governance can be a big economic chance for the densely populated area of Bangladesh that has to

face serious obstacles because of the lack of accessibility owing to poverty and illiteracy. In order to serve the low-educated community, an audiovisual system for e-services in Bangladesh is presented. The paper also discusses how this system will look like, which chances it offers, what basic structures it will require, how to establish it in an urban context and which impending problems may appear during the implementation.

### **Keywords:**

marginalized and poor, audiovisual interaction, access point, densely populated zone



## Introduction

E-governance is a valuable information and communications technology (ICT) tool with which to reach a wider population through various online service deliveries and options, including mobile devices. The benefit of the new technology is the maximization of rapid and effective information transfer to communities and individuals. Despite the benefits it already offers, “e-governance initiatives (...) should look for ways of enhancing people’s participation in policy decision-making and other governance processes” (Raúl Zambrano, 2013). In the South Asian environment, e-governance can be applicable if the public has proper access to such services. Therefore, it is necessary to provide possible solutions to the lack of information support and access to governmental services. In order to solve the problems in relation to illiteracy, implementing an interactive audiovisual system along with the conventional computing methods can be a sensible approach.

The objective of this paper is to promote the concept of an information system for e-governance activity for the lower income group, which has limited or no education. Hence, the discussion will be confined within the alternative technology options and means to focus on the issues and obstacles with literacy and accessibility. As the fields government-to-government or e-administration and government-to-business are not applicable to this chapter, the focus will lie on the government-to-citizens or e-services part, only.

In order to reach the marginalized and the poor, the proposed system will consist of service centres, access points and mobile phones. In the following chapter, the term “service centre” means an operating office with executives providing the receivers with the requested information. The term “access point” refers to machines similar to Automated Teller Machines (ATM booths), functioning as easily accessible information points for the receivers. The paper will also discuss how this system can look and its required basic structures. This work can be a helpful contribution to the establishment of an e-governmental system fitting to the specific demands of South Asia, where the majority of people cannot even afford access to the Internet. This paper will work as a design proposal based on the current situation of South Asia and will explore the possibilities that can be implemented immediately. As the prototype of a densely populated area in South Asia, Bangladesh is taken as the case study.

## The conditions for e-Governance in Bangladesh

Bangladesh is a densely populated country of about 156,600,000 inhabitants (Worldwide Governance Indicators, Country data report for Bangladesh, 1996-2013, 2013). It is considered a developing country with a gross national income (GNI) of USD900 (Worldwide Governance Indicators, Country data report for Bangladesh, 1996-2013, 2013). The gross domestic product has been growing in recent years at 6-7 per cent per annum since 2004 (Worldwide Governance Indicators, Country data report for Bangladesh, 1996-2013, 2013), which is unquestionably a positive indicator of developing countries.



INFORMATION ON WORKING HOURS, HOLIDAY, SALARY DETAILS, BONUS OFFERS, JOB VACANCY AND OTHERS CAN BE PROVIDED VIA PUBLIC ACCESS POINTS. THE ESTABLISHMENT OF A SYSTEM OFFERING THESE SERVICES CAN LEAD TO GREATER TRANSPARENCY AMONG THE PARTICIPANTS TO GUARANTEE FAIR WORKING CONDITIONS.



Alike other developing countries, the number of fixed telephone and mobile phone users is increasing yearly. Roughly, 57.5 per cent of the total population uses telephone services. On closer examination, the number of telephone subscribers increased from 74,188,000 in April 2011 to 115,627,000 in April 2014. This growth can also be observed in Internet users, whose number rose from 33,043,000 in April 2013 to 37,172,000 in April 2014 (BTRC 2013 and 2014). Such an increase of telephone and Internet users suggests that e-governance can play a key role for the economic and social development of Bangladesh.

## Advancement

The Government of Bangladesh has made several efforts to establish e-governance in the country. More than 50 per cent of the ministries have their own Local Area Network (e-Governance Horizon Scan report, an assesment study of e-Governance in Bangladesh, 2007). Electricity, telephone and gas bills can be paid via the Internet today. Different governmental information is already available along with documents that the public can download free of charge from the Net. The trend is developing, apparently slowly. Currently the government aims to achieve a “Digital Bangladesh” in 2021. So, in June 2014, it upgraded and launched a new website while announcing it had 50,000 trained officials to operate and maintain the system. This particular website is designed as “one-stop service point” and is interlinked with all governmental organizations. The Bangladesh Post Office started Electronic Mail Services (e-post) via 16 general post offices. Additionally, 1,000 telecentres (e-Governance Horizon Scan report, an assesment study of e-Governance in Bangladesh, 2007), as well as cyber cafés, e-mail and videoconferencing facilities

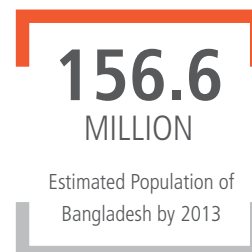

are available. The integration of ICT in the private sector is increasing, depending on the business area. The number of ATM booths, sales points with electronic cards, SMS-banking, telebanking is increasing continuously. Moreover, several devices for public access of e-services called Union Information and Service Centre have been established recently. These centres, which are part of the so-called "a2i"-programme (Access to Information Programme, n.d.), are supported by the central government and operate at all 4,547 Union Parishad – the country's lowest branch of local government. The centres consist, in general, of technical tools like computers, printers and digital cameras. Though these centres are meant to support the entire nation, especially rural folk, with e-services their outcome for the lower income group is questionable, as the provided information is not specified for them and requires certain language and basic IT skills. All these facts show the positive advancement in terms of e-governance in Bangladesh. The efforts are already visible, but still the development of the system remains a slow and time consuming process.

## Backlogs

Despite past efforts, the establishment of e-governance still faces considerable backlog. The previously mentioned demographics indicate a positive growth for Bangladesh, but a comparison of growth-related data with other sets of data clarifies the true condition: 49.6 per cent of the population earn less than USD1.25 (purchasing power parity) per day. Therefore, half of the total population cannot directly avail the equipment required for e-services (Ahmed Imran, 2010). Along with this data, the literacy rate must be taken into account. Officially, the adult (15+) literacy rate is at approximately 55.9 per cent, but the level of standard can be questioned because the mean duration of schooling is 4.8 years for the adults aged 25 and older. This means that half of the population lives below subsistence level and has not completed primary education (Halil Dunder, 2014).

In the country's urban context, the headcount rate (Head count rate (CBN), 2005) of incidence of poverty ranges between 14.6 per cent (lower poverty line) and 28.4 per cent (upper poverty line). In addition to that residents of informal urban settlements face various problems like a lack of sanitation, safety, medical support and educational facilities. This is particularly so in less developed urban areas where there is barely any access to the existing e-services. Along with that comes a lack of supporting devices and power supply that would be needed to operate services. Currently, access to e-services for a wider population in the urban regions seems to be an ambitious target, due to the costs of these services and the lack of necessary power supply. In addition, a lack of required know-how and a preservation of the traditional and centralized organizational structure impedes the effectiveness of e-governance (Ahmed Imran, 2010).

## The necessity of An audiovisual communication system

In the following part a possible solution will be presented for enhancing access to e-services. The paramount challenge e-governance faces lies in the transfer of information via the Internet and the requirement of computers or similar technologies for their reception. This may seem like a technical issue, but it becomes a huge obstacle to the

low-income group and the low-educated community, which includes almost half of the nation's population. In most of the cases, it is still difficult to operate when most people cannot read and are unaware of technical tools in general. The solution to this deficiency can be an appropriate communication system that includes service centres and communication devices. Currently, most of the government websites only provide information in English. According to the (e-Governance Horizon Scan report, an assesment study of e-Governance in Bangladesh, 2007), 98 per cent of the people communicate in Bangla, so it would be much more effective to deliver the information in Bangla as well as in English. Yet information provided only in a written format will not be very effective due to the lack of literacy. Therefore, this paper (Md. Zohurul Islam, 2012) suggests an audiovisual method along with a written one be used to communicate information. If the entire system can be operated on an audiovisual basis, more users can be reached.

Some audiovisual approaches have already been applied in South Asia, like the above-mentioned "a2i"-programme in Bangladesh, or India's "National e-Governance Plan Project", presented below. These efforts did not have any effect on the low-educated or illiterate groups, because they were not targeted. In general, the efforts to apply audiovisual approaches adopted in South Asia are largely insufficient to reach a wider range of recipients, especially the marginalized and the poor. The main reason for this is a missing design for people who are unfamiliar with the devices and applications necessary for e-services. The audiovisual system, presented here consisting of mobile phones, access points and service centres can be a solution to this problem. By the implementation of the proposed system, the urban poor of South Asia will be able to participate in future e-governance processes.

## Information That Can be Provided in the Urban Context

By establishing an audiovisual system, a wide variety of information can be provided in a bundled and synergetic way. Daily prices, local government rules, safety issues, transport- and traffic-related information, weather forecasts as well as educational services can be easily accessed. In the densely urban areas lacking medical support, the health-related issues are of predominant significance. Common diseases like malaria, diarrhoea and cholera require access to information on preventive measures and primary remedies. In addition, the government can use the information system as a tool for monitoring local health issues and necessities in the communities. Informal urban areas often require individual approaches that a standardized operating system applicable for the whole county cannot offer. Instead of a bare application of borrowed "off-the-shelf" solutions from the West, local contexts must be considered and embedded in the design. It is obvious that a red light district like that of Narayangang struggles with unique problems related to sexually transmitted diseases like HIV, which may be prevented by providing relevant information. In addition to that, serious violations of human rights like child abuse, rape, human trafficking and illegal drug use are common problems in local brothels. In most of these cases there is hardly any chance to report these crimes. The installation of an easy-to-handle interactive system may offer solutions to these problems. With such a system, legal aid can be offered in any other context of

the urban regions as well. In contrast, other regions have different structures with variant requirements. In the informal settlement at Savar, industrial workers – especially in the garment industry – constitute the majority of the marginalized and the poor community. Frequent strikes among workers have negative effects on the business community and thus on the governmental organization. Fair wages, length of working day and safety issues are the most controversial topics. Information on working hours, holiday, salary details, bonus offers, job vacancy and others can be provided via public access points. The establishment of a system offering these services can lead to greater transparency among the participants to guarantee fair working conditions.

### The Establishment of Service Centres

In order to transfer e-services to the marginalized and poor, service centres are required. The way by which this distribution system might function has been proposed in a number of research papers. To deliver e-services to the receivers, a group of service centres with specialized and trained manpower is obligatory (Islam, 2009). Providing specific help and guidance up to general and regular data monitoring, as well as updating will make up part of their tasks. The required specialized manpower is available in Bangladesh and just needs proper management. Besides the already trained employees for the “Digital Bangladesh 2021” project (Bangladesh National Portal Launched, Milestone to Achieve Vision 2021, 2014), many graduates from Bangladesh can be employed at the centres. According to the report of the ministry of finance for the

year 2011, 25 public universities, 46 private ones and many training centres are teaching ICT in the country (BANBEIS, 2012). As the existing infrastructure already has e-service centres in 64 districts (Md. Zohurul Islam, 2012), these can also be used for the proposed system.

### Improving Access to Provided Services

The idea of including the marginalized and poor community with e-services is a challenge in itself. For e-governance, an Internet database, an Internet connection and information receiving devices are required. The possible options can be mobile phones (basic or smart) or computers and access points. Considering the target group with limited income and education, the recommended options are basic mobile phones and access points. As this group cannot own personal Internet operating devices like smart phones or computers, these can be neglected here.

#### a. Mobile phones

The first proposed option is a basic mobile phone. The increasing number of mobile phone users is an indicator for this device can be useful for e-governance. Much basic information can be transferred via mobile phones. The current application of e-governance via mobile phone is mostly one-sided and rarely reciprocal. In the current e-governance system of Bangladesh, information via short message service (SMS) is already available for different services such as emergencies, weather forecasts, health-related campaigns, results of public exams and passport delivery updates. The service can be more efficient when it is not

Figure 1: E-Governance

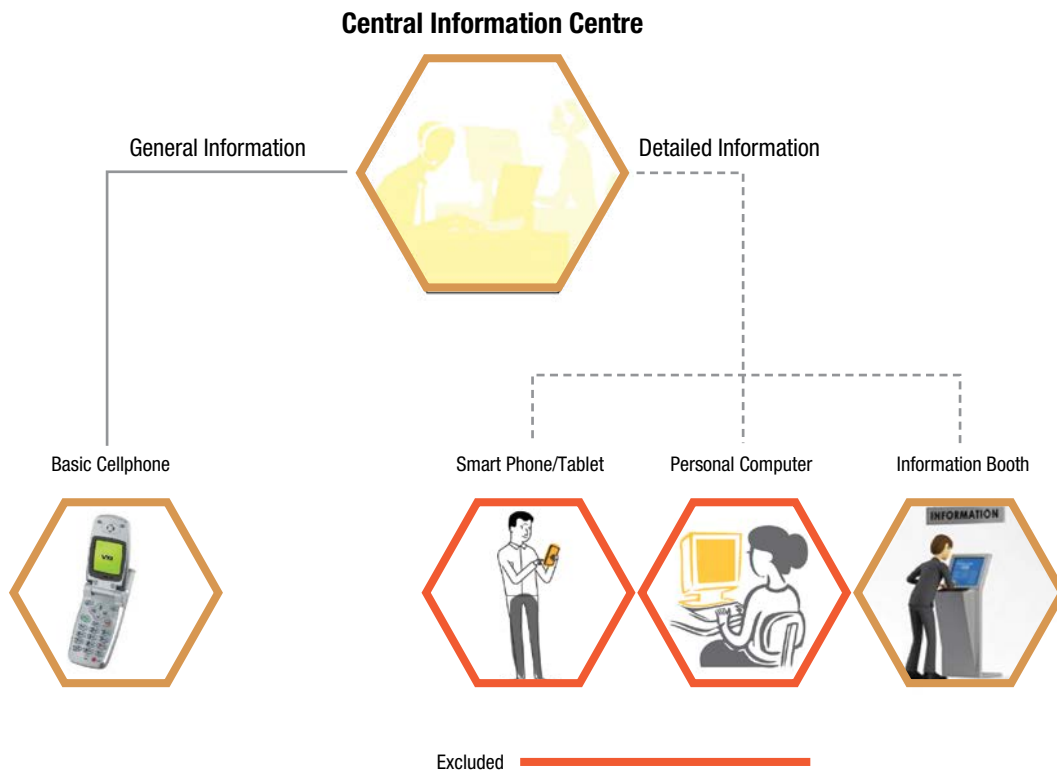

limited to SMS. A basic mobile phone can be used for e-governance by integrating the audio system that passes information based on dialing certain numbers or by providing voice commands. Calculating from zero to nine can be considered a minimum standard that anyone can fulfil.

The range of possible services and information transferred via mobile phone is wide. Recently installed examples of helplines are successful in different ways. A project in India called "childonline" (Childonline, 2014) has been adopted for women and to provide support to victims of child abuse. This commonly accepted project, which started in the city of Mumbai in 1996, offers a toll free helpline for street children. A comparable realization of this successful project seems rather complicated in Bangladesh. A recent example is the so-called "Krishi Call Centre", which was launched by an NGO called "Practical Actions" in 2012 (Krishi Call Centre, 2014). This project includes a toll-free number to provide farmers agricultural information. By dialing 16123, farmers can call a centre for information on agriculture, fisheries and livestock. During the experimental phase, about 35 calls from farmers were solicited each day. The initial support - the collection of about 5,000 questions and answers as well as the further operation - was realized by "Practical Actions" for 18 months (Krishi Call Centre, 2014), until the project was handed over to the Ministry of Agriculture. While the project was an experimental success, the process slowed after the Ministry of Agriculture took full responsibility. This will probably not be the only example of a successful initial phase that ends up failing during its roll out on a wider range. The example also shows that

the challenge lies in taking the initiative and in managing as well as continuing the process.

### b. Access Points

Where people do not have mobile phone access or where a more specified service is necessary, another way of communication must be found. As an alternative support, the establishment of access points is necessary. This option offers the chance to overcome the limitations of mobile phones and the problems of illiteracy (Halil Dunder, 2014). By installing access points providing audiovisual services, a wide range of people in Bangladesh can be reached.

The idea of installing access points to serve the "common man" has already been launched in other countries. Among these countries, the most ambitious project is probably the so-called "Common Service Centre Scheme" in India. This is part of the National e-governance Plan Project. It is organized as a public-private partnership with a budget of 270 billion rupees (about USD4.25 billion). The initial goal to install about 100,000 "telecentres" has almost been reached, so that the country is theoretically supported nationwide. These centres are supposed to offer services in education, telemedicine, agriculture and entertainment (Rajanish Dass, 2011). Although the efforts for implementing the project have been huge, it has been criticized for its poor demand and affordability among its users. Because it is predominantly useful to the higher-income groups, the system ignores the problems of illiteracy, local language contexts and relevant applications for the poor (Rohit Prasad, 2012).

#### (i) Suggested Features of Access Points

For an efficient application, the access points must provide certain facilitating features. Considering the very technical features, there are already many technologies available which can be used for the proposed audiovisual access point. The current technology supports the following options that can be considered:

Audio guidance to instruct the users: audio instructions can ensure that the information can be passed to a greater audience. Many vending machines and GPS-devices are examples.

Scanning voice command: this option will also avoid the necessity of writing. Google devices and many phone operators use similar technology.

Touch screen/button tab option: these are very basic necessary options to ensure that the system works well. Many public ticket booths as well as vending machines in western countries use them. These machines should have durable metal buttons so that maintenance costs are kept low.

Close circuit camera for the operators in case of emergency: this is a necessary option to ensure the effectiveness of the service. The operator can see the person and intervene, if required. Face detection can also ensure safety and will reduce vandalism of the info-centres. ATM booths elaborately use such devices.



**People talking on the phone. Collage made network connection of diversity races. Asian communication concept.**

© Shutterstock/szefei

**270**  
BILLION RUPEES

The budget of the National e-governance Plan Project in India, organized as a public-private partnership.

Use of logos, pictures and colour codes instead of written formats: it is easier to incorporate signs and colours to pass information. This is also a good alternative to written information. A very simple example of this is the signal light, where red means “no” and green “yes”. Logos can also carry various meanings. The best-known example is the voting ballot used during the election in Bangladesh.

Engraving for visually impaired: standardized machines often use such engravings. Besides the audio system, the use of braille will help the visually impaired community to get easy access. This can also enlarge the acceptance of the system and encourage its use by all.

Operating option with valid identification/pin code: in order to avoid misuse of the machines, a personal identification code is needed. One possible option can be the voter identification number, whose database has been updated recently. In 2007-2008, the government successfully completed the “voter ID project”. Around 80 million people were registered, which now makes it the world’s largest such database. Every person received a national ID-card including their own photo and an individual number (Ahmed Imran, 2010).

## (ii) Possible Sites Access Points

In the following part, possible locations for the access points in urban areas will be discussed. Considering the urban compactness of South Asian cities, the innovative use of space is obligatory; and every fine detail counts.

The urban information centres presented here aim mainly at the marginalized and poor. The locations of the access points require easy accessibility for this target group. The closer the point is to the user at home or at working places, the more effective it will become and more likely to get people involved in e-governance. Similarly, an equally distributed grid design for positioning access points may be a reasonable choice for many cities, but for Bangladesh this system may not be efficient because of its uneven population density. Here the location of the points should rather follow the population density map, as the marginalized and poor mostly live in dense areas.

Traffic issues, transport costs and required time to reach the access points should be taken into consideration. The information centres should be within walking distances. This can make the operating system cost-efficient and hassle-free. The centres may be colour coded. For ease of navigation, a location map of the centres can be provided at

different public spaces.

Possible locations can be bus or train stops as well as factory zones. Public and post offices, hospitals and markets are also easily accessible. Considering the land availability, cost and security, information centres might be integrated within other public buildings. In urban contexts schools are not recommended as a location. It is common to select educational institutions during elections as voting venues, but their daily use as access points might endanger pupils whose safety is of paramount importance.

## Implementation Recommendations and Impending Obstacles

As the operation of the presented system requires planning, some implementation recommendations as well as impending obstacles will be presented here.

Initially, the installation of one or more prototype units consisting of one service centre connected to an access point and a cell phone network is recommended. Here the practical suitability and the appearance of technical obstacles can be supervised in a smaller frame. After a successful test phase in which the processes can be optimized, the locations for the service centres and the access points must be defined according to the population density and local requirements, then the installations can be made. As the Access to Information (“a2i”) – infrastructure already exists, it can also be used here as long as the locations and services are optimized and the staff is trained in line with the desired goal. This will require specializations and adaptation to the new system with its special devices and services, as well as coordination of the varying databases. In addition, the number of service centres needs to be increased and adapted to the population density map of the urban regions.

The most striking challenge for the implementation of the service will be the provision of energy, as it is the prerequisite for ICT infrastructure (Md. Zohurul Islam, 2012). Therefore, alternative power sources must be secured before the installation of the service centres and access points can take place.

The three State-owned bodies - the Bangladesh Power Development Board, the Dhaka Electric Supply Authority (and the Rural Electrification Board - are the public entities responsible for power supply. According to the Ministry of Power, Energy and Mineral Resources’ Power Sector Updates for 2014, only 3,267 megawatts were generated, instead of 5,200 MW needed to meet present national demand. The target was to raise the power generation up to 5,000 MW by 2011 and 7,000 MW by 2013 to keep up with the growing demand (Power Sector Updates, 2014).

The continuous development of Bangladesh’s solar industry and more efficient energy storage can be a solution to this problem. One example is an e-learning school for underprivileged children called “The Light of Hope”, which started a project completely based on solar-generated energy for its equipment. This kind of energy support can be applicable to the access points presented here.



Once the power supply and an uninterrupted Internet connection is guaranteed and the system is running, its promotion should be pursued because most people in Bangladesh are still unaware of e-governance. Although the government has already made promising efforts with the “Digital Bangladesh” project, the system will only function properly if people know more about e-governance and how to use its facilities (Raúl Zambrano, 2013). The public needs to know which services exist and their benefits (Md. Zohurul Islam, 2012). The success of e-governance in countries like Bangladesh depends on the number of successful users, along with regular service updates. Thus a strong marketing strategy is needed. Creating small workshops for the community and advertisements demonstrating how easily accessible and useful the access points are is highly recommended. In addition to that, the installation of a model point for promotional purposes can be part of the marketing strategy.

In order to react to expected or unexpected problems during the implementation of the presented audiovisual communication system in the urban areas, the establishment of certain key success indicators is highly recommended. This can be ensured by an efficient monitoring system. The outcome of the system can be measured through direct or indirect feedback, which can consist of different elements. The basic method can be to get a regular satisfaction report in at daily or weekly intervals, which can be implemented by measuring the frequency,

the duration and the individual demand, and type of usage of the different services. Supplementary information on the usage and the weaknesses of the system can be obtained from questionnaires sent to key users from the urban areas of different age groups, professions and gender. The monitoring system for the access points will require close observation of the users' behaviour, based on locality and profession, to understand each community's needs. This combined monitoring and observation process will help in the redesign of the system and its adaptation to the individual local contexts and demands. Regular monitoring and continuous improvement on that basis will ensure the success of this proposed system as a two-sided and interactive process.

## Conclusion

The paper presented a possible solution to insufficient access to e-services for the people living below the poverty line in Bangladesh. With the establishment of audiovisual-based service centres providing information and services to mobile phone and access point receivers, the information exchange at that lower level can be enhanced. The paper discussed ways of distributing the provided services in the urban context and showed the impending problems with the implementation of these structures. The application of the presented system can finally lead to a fairer way of participating in the e-governance processes and thus help to improve the general living standard in Bangladesh.

## References

- Access to information (a2i) program. (s.d.). Available from Access to <http://a2i.pmo.gov.bd/>
- Ahmed Imran, S. G. (2010). Uncovering the Hidden issues in e-Government adoption in a least Developed Country: the Case of Bangladesh. *Journal of Global Information Management*, vol. 18, No. 2 (April-June), 30-56.
- BANBEIS. (2012). Available from Bangladesh Bureau of Educational Information and Statistics: [http://www.banbeis.gov.bd/webnew/index.php?option=com\\_content&view=article&id=316&Itemid=171](http://www.banbeis.gov.bd/webnew/index.php?option=com_content&view=article&id=316&Itemid=171)
- Bangladesh National Portal Launched, Milestone to Achieve Vision 2021. (2014, June 23). Available from Access to Information (a2i) Program: <http://a2i.pmo.gov.bd/content/bangladesh-national-portal-launched-milestone-achieve-vision-2021>
- BTRC. (2013, April). Available from Bangladesh Telecommunication Regulatory Commission : <http://www.btrc.gov.bd/content/mobile-phone-subscribers-bangladesh-april-2013>
- BTRC. (2014, April). Available from Bangladesh Telecommunication Regulatory Commission: <http://www.btrc.gov.bd/content/mobile-phone-subscribers-bangladesh-april-2014>
- Charu Malhotra, V. C. (2011). Citizen-centricity for e-Governance initiatives in Rural Areas. Indian Institute of Public Administration. Available from <http://www.unapcict.org/ecohub/citizen-centricity-for-e-governance-initiatives-in-rural-areas>
- Childonline. (2014, September 13). 'Childline 1098 service'. Available from <http://www.childlineindia.org.in/>
- e-Governance Horizon Scan report, an assesment study of e-Governance in Bangladesh (2007). Access to Information (A2I) programme.
- Hallil Dunder, T. B. (2014). Student Learning in South Asia, Challenges, Opportunities and Policy Priorities. Washington DC: The World Bank.
- Head count rate (CBN). (2005). Available from Bangladesh Bureau of Statistics: [http://www.bbs.gov.bd/RptHIES6\\_2.aspx?page=/PageReportLists.aspx?PARENTKEY=67](http://www.bbs.gov.bd/RptHIES6_2.aspx?page=/PageReportLists.aspx?PARENTKEY=67)
- Islam, G. Z. (2009). E-Governance Implementation in Metropolitan and Rural Areas of Bangladesh: An Illustrative Prototype. *International Technology Management Review*, 2 Number 1 (October), 33-49.
- Krishi call centre. (2014, June). Available from Practical actions: <http://practicalaction.org/krishi-call-centre-bangladesh>
- Md. Zohurul Islam, R. K. (2012). Preparation of E-Government in Bangladesh: An Exploratory Analysis. *JU Journal of Information Technology (JIT)*, 1 (June), 19-26. Available from [www.juniv.edu/jujit/files/2012/09/4.pdf](http://www.juniv.edu/jujit/files/2012/09/4.pdf)
- Power sector updates. (2014, May 22). Available from Ministry of Power, Energy and Mineral resources: <http://www.powerdivision.gov.bd/user/brec/85/85>
- Rajanish Dass, A. B. (2011). Status of Common Service Center Program in India: Issues, Challenges and Emerging Practices for Rollout. INDIAN INSTITUTE OF MANAGEMENT, W.P. No. 2011-02-03. Available from <http://www.iimahd.ernet.in/assets/snippets/workingpaperpdf/2011-02-03RajanishDass.pdf>
- Raúl Zambrano, R. K. (2013). From Connectivity to Service Delivery: Case studies in e-governance. New York: United Nations Development Programme. Available from <http://www.undp.org/content/dam/undp/library/Democratic%20Governance/Access%20to%20Information%20and%20E-governance/From%20Connectivity%20to%20Service%20Delivery%20-%20Case%20Studies%20in%20E-Governance.pdf>
- Rohit Prasad, R. S. (2012). Critique of the Common Service Centre Scheme. *Economic & Political Weekly*, xlvi (6), 18-23. Available from <http://www.indiaenvironmentportal.org.in/files/file/Service%20Centre%20Scheme.pdf>
- Worldwide Governance Indicators, Country Data Report for Bangladesh, 1996-2013. The World Bank. Available from <http://info.worldbank.org/governance/wgi/pdf/c20.pdf>



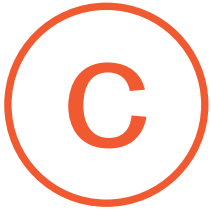

# Dumb Phones, Smart Youth:

## Impact of ICT and Mobile Platforms on Youth Engagement in Local Governance

○ Daniella Ben-Attar  
Israel (daniella.benattar@gmail.com)

○ Tim Campbell  
USA (timcampbellphd@gmail.com)

### Abstract ○

This purpose of this paper is to explore the current and potential impact of mobile platforms on civic engagement of urban youth in local governance in developing countries. The population of youthful actors is at the forefront of a mobile information and communications technology (ICT) revolution in cities of the developing world. The paper aims to provide insight into how “narrowband” mobile platforms are being used by and for youth to overcome social, political and economic exclusion to begin driving positive change

in their communities. The authors draw on 50 case examples to illustrate how mobile platforms accelerate youth civic engagement, transform interaction with local officials, and exert pressure on local and national governments. The chapter identifies trends, spots barriers and opportunities, and indicates what local and national governments can do to foster and strengthen democratic participation of young citizens by means of mobile platforms.

### Keywords:

ICT, mobile, youth, urban governance, engagement



## Introduction

Two global trends—the so-called “youth bulge” and the “mobile miracle”—are having dramatic and transformative impacts on governance, particularly local government, across the world. The youth bulge refers to the 15-24 year cohort (29 by some definitions), the largest cohort in history, numbering more than 1.2 billion people. At present, 87 per cent of this cohort group live in developing countries, and a majority of young people reside in cities. An estimated 60 per cent of all urban dwellers will be under the age of 18 by 2030 (UN-Habitat, 2012). Despite their growing number, youth are largely excluded from participation in local and national decision-making, leaving them socially and politically marginalized. Many live in informal settlements where opportunities for dialogue with governments are scarce. At the same time, young people have been at the forefront of the rapid developments in ICT, particularly the mobile miracle.

The miracle refers to the explosive growth of hand-held cellular phones, particularly low-end mobile devices which, in contrast to modern smartphones, are limited in capabilities and are thus often referred to as “dumb phones”. The growth of these devices over the past decade has been spectacular. Penetration rates are 96 per cent globally and 89 per cent in developing countries (ITU, 2013). Youth are at the centre of these developments, both as drivers and consumers of technological innovation. They are almost twice as networked as the global population, with the ICT age gap more pronounced in least developed countries where young people are often three times more likely to be online than the general population (Pew Research, 2014).

The confluence of these two trends has many social, political and civic impacts. This chapter will explore how the widespread use of mobile devices among the youth cohort is beginning to transform civic and political relationships of youth with their local governments. Few need to be reminded of the role mobile phones played in the Arab Spring, where a largely youthful population participated massively in political communication and revolt. Similar awakenings are taking place in communities around the globe as youthful citizens are putting “dumb” technological tools to effective use on issues that affect them: jobs, education, health and accountability of local government.

## Background

Much of the literature on ICT and local government has concentrated on e-portals and citizens’ access to government services to obtain items such as licenses, permits and records. These early developments were characterized by the generic term “e-government”, which concentrated on increasing the efficiency of government operations and services through the Internet. Backus mapped out the main Internet-based applications in 2001 (Backus 2001). Later literature distinguished between this (e-government) and e-governance, the latter being a broader concept including the use of ICT by various actors in society to enhance citizen engagement in expressing voice, making choices, and shaping political institutions (Palvia and Sharma, 2007). The very fact that Backus expressed an implicit “direction” in the linkage between citizens and the governed—emphasizing the centrality of government—reveals how quickly relationships have changed since the turn of the millennium. Subsequently, academic studies and practitioners began

to reflect a shift from citizen-centric and citizen-driven electronic government (UN-Habitat, 2012). Finally, when discussing these trends in a developing world context, the term m-governance (mobile governance) has been used to reflect the limitations in infrastructure and rapid uptake of mobile technologies alongside the development of innovative mobile applications utilizing ICT for the public good (OECD/International Telecommunication Union 2011). Recent literature has focused on the role of mobile-enabled social media in support of governance (DANIDA, 2012).

While literature on youth and ICTs has received significant attention, not much scrutiny has been directed toward urban youth with mobile devices in the developing world. The first significant study of this issue was published by ITU in 2013, presenting a model to measure the “digital native” population worldwide, analysed by region, development level, income grouping and educational enrolment levels (ITU, 2013). “Digital natives” are defined as the population of networked youth, aged 15-24 years, with five or more years of online experience. The findings highlighted a need for research into how growing up in a digital age is impacting the way young citizens in developing countries think, learn and engage in civic activity. While groundbreaking in nature, the ITU study limited its definition of online experience to Internet usage, thereby leaving out the massive numbers of young mobile phone users and the momentous impact that these simple devices are having in their daily lives. Where in-depth attention is given to how mobile phones are impacting developing countries in general and governance in particular, these analyses have not applied a specific focus on youth issues and youth engagement in this context (World Bank, 2012). Indeed, the literature has taken a siloed approach, focusing on trends of ICT, local governance and youth engagement, separately.



**An unidentified nomad mother on a cell phone in the Sahara desert on Dec. 28, 2012 in Morocco. The telecom regulator ANRT reports mobile penetration in Morocco at more than 110%.**

© Shutterstock.com/cdrin

This chapter attempts to examine the intersection of these areas to consider how ICTs, particularly mobile usage, affects youth engagement in local governments of the developing world.

## Methods and Cases

A body of empirical data of 50 cases was developed for the present review. See Annex I. Cases were drawn from reviews of literature and web searches, screening for a youth dimension in applications of ICT that affect local governance. Cases were confined to sponsored and spontaneous uses of technology—covering mobile phones, apps and software, mostly but not exclusively narrowband and sometimes in conjunction with other technologies, including radio and the Internet. Thirty-eight of the cases were discovered by means of Internet search. An additional 12 cases were uncovered in connection with previous or present work with the World Bank, the United Nations, non-governmental organizations (NGOs) or other sources. As part of the field work, 26 interviews were held by phone or in person with youth; local government staff and officials; activists and practitioners in related fields; and 12 of the interviews with persons directly involved in the cases reviewed (Annex II). A draft document was then shared with youth and practitioners in consultations in order to obtain further input before finalizing the analysis (Annex III).

In all instances the cases link young citizens, and in about half the cases citizens of all ages, in some way to the practice or policy of local governments. For the most part, the cases are drawn from experiences outside of the developed, post-industrial world. Only four cases are drawn from developed countries, but about one-fifth are global in nature; that is in the public domain and available to users anywhere on the globe.

We can make no claim that the cases considered in this analysis are in any way representative of the myriad of applications that might be found of youth-related ICT on governance. At the same time, there is no obvious bias in the method by which this data was collected, although geographical representation is uneven, favouring Africa and Asia over Latin America and the Caribbean, Eastern Europe and countries in the post-industrial world.

## Key Characteristics of Cases

The case experiences are all projects or practices organized by a sponsor, usually a government, a youth group, or other NGOs. Government and youth groups account for two-thirds of the “sponsors” or organizers of the case examples. The rest are other NGOs or businesses; for instance, telecommunications providers. Viewed from the perspective of target group or objective, over half were aimed at youth; the second largest share, nearly 40 per cent, was aimed at citizens in general. The large number of ICT initiatives sponsored by youth groups reflects the creative and dynamic nature of ICT in the hands of youth. Young users are energetic and creative in exploring ways to connect with others in relationship to community and local government. They also lend credence to the notion that youth are in many ways the leaders of ICT governance initiatives for all citizens – innovating technology, generating content and developing applications. As such, inquiries into

this issue must go beyond the basic question, “How can ICTs improve urban governance for youth?” They should also ask, “How can youth help harness ICTs to improve urban governance for all?”

We turn now to examine how each of the cases relates to four areas of ICT-enabled governance, emphasizing as much as possible the local level of government. We adopt a framework defined by UN-Habitat that relates ICT to key features of urban governance. The framework, presented by UN-Habitat (2012)<sup>1</sup> is a practical and results-oriented approach and has the advantage of applying a youth lens to key domains of ICT-enabled governance. The framework consists of the following four elements:

1. Balance of inclusiveness and responsiveness when using technology.
2. Engaging young citizens as partners in urban governance.
3. Public openness through technology.
4. Impact on outcomes for youth.

The reader should note that often the cases reviewed in this study are multidimensional and can easily represent more than one of the four areas. Notwithstanding this possible methodological “noise”, the cases indicate that applications of ICT and youth cluster primarily in two key areas: inclusiveness and engagement. See table 1.

The distribution in table 1 reflects a logical outcome of ICT, particularly our focus on mobile platforms, in the hands of youth. Mobile platforms with such applications as social networking naturally favour horizontal linkages of exchange among peers. Areas 1 and 2 also intrinsically involve dimensions of connectedness, communication and exchange. On the other hand, areas 3 and 4 refer to somewhat more internal aspects of local government, ones that require deeper engagement—by citizens and government—to develop and share knowledge about internal processes and to improve government services.

We now turn to a more detailed, qualitative analysis of our principal findings below organized according to the four areas of governance outlined.

**Table 1** Case Impact by Area of Governance

AREA OF GOVERNANCE	OCCURENCE
1 – Inclusiveness & responsiveness	11
2 – Engaging young citizens	23
3 – Public openness	10
4 – Outcomes	6
<b>Total</b>	<b>50</b>

## Findings in Four Areas of ICT-Enabled Governance

### 1. Balancing Inclusiveness and Responsiveness when Using Technology

Information and communications technologies are enabling greater inclusion of youth viewpoints in governance, and in some cases new or more responsive services. These developments are linked to the way in which young people are reshaping civic discourse by means of ICTs, particularly mobile platforms. New avenues are being created to allow increased youth opinion; young people are being empowered to provide user generated information to policymakers, and a wider spectrum of youth is being engaged.

Pervasiveness of mobile phones increases the “voice” of the youth and puts a premium on local governments’ responsiveness. This phenomenon was non-existent a decade ago; today it represents a potentially momentous change in government-youth relationships. As a veteran youth leader from Kigali said: “A few years ago, a leader would usually go down to the field one day and go back to the same place only one year later and in between there would be no way to reach him or make him accountable. Now the bond with social media is reaffirmed on a daily basis. Leaders can’t just promise things and disappear.”<sup>2</sup> The increased volume of traffic is increasingly difficult for governments to ignore. Instant communication and social networking trends offer young people unique and unprecedented tools with which to leverage opinion and political influence.

Our findings suggest that increased responsiveness on the part of early adopters in government (local and national) gives young people new access to leaders and leadership positions. In many cases, electronic communications shortcut conventional modalities of citizen-municipal communication, thereby obviating the slow and cumbersome personal appointments and official meetings in municipal offices. Today an ordinary young person can interact with government offices, see rapid results of appeals and even communicate directly with the president of a country and get a response. This was unthinkable just a few years ago. Mayor Jerry Silaa of Ilala Municipal Council in the Tanzanian city of Dar es Salaam confirms the impact that social media has had on his own agenda: “I can assure you that twenty per cent of the events I attend come from online social networks. If used well, ICT can be a very good method to engage the community – but it should be used as a means to an end, not as an end in and of itself.”<sup>3</sup>

Mobile phones can also improve the quality and quantity of user-generated information in a way that transforms understanding of the status and needs of youth by public officials and local government bureaucrats. Conversely, youth groups are more aware of the limitations and possibilities of local governments in providing services. User-generated content among youth is a key ingredient to this process. In Uganda, a UNICEF supported programme run by local youth organizations titled Ureport has created a platform for strengthening communication and dialogue around core development issues through short message service (SMS) and the radio. With over 89,000 Ugandans

signed up and participating by March 2012, young “social monitors” are sent regular polls, gather data on community services and issues, and receive useful facts for action and advocacy - providing the “pulse” of Ugandan youth.<sup>4</sup>

Mobile devices allow for the effective scaling up of participation by the young. Young leaders can reach unprecedented numbers of their peers with their projects and programmes, including the previously unengaged and disadvantaged, giving a voice to the voiceless. For instance, ICT opens new channels for youth with disabilities, whether or not it be to speak on issues such as employment, education and governance.<sup>5</sup> Mobile platforms also lower what can be termed the “threshold of entry”; that is they help those who are less disposed to speaking out, and those in younger age groups express themselves more easily than in face-to-face meetings at which they often feel intimidated or insecure.<sup>6</sup> In addition, community mapping efforts illustrate the power of ICT tools to draw in a wider circle of activists, spreading to new and sometimes unforeseen impacts in health, security and community cohesion.

Radio still remains the most effective tool for reaching the public, particularly when it comes to disadvantaged and poorer communities. Many cases demonstrate an effective combination of radio and mobile phone for including wider sections of previously unengaged youth in civic activity. In Nepal, the Voices of Youth project enables teens to use text messages (SMS via toll free mobile phone number) for self-expression and peer-to-peer support broadcast on radio programmes that are heard by 6.3 million youth. Youth are invited to speak or text on a range of topics. The station has received over 33,000 messages since the launch, which comes from approximately 4,000 listeners. The toll free initiative connects the website, mobile and the radio network.<sup>7</sup>

The mobilization of youth and amplification of their voice through ICTs can also influence decision makers to create new channels for offline youth engagement. The Khanyisa Youth Network in South Africa established a youth-led mobile radio programme connected to social media and mobile phones reaching at least 300,000 people. The broadcasts have helped sensitize local government to youth needs, challenges and aspirations, eliciting new interactions and outcomes.



MOBILE DEVICES ALLOW FOR THE EFFECTIVE SCALING UP OF PARTICIPATION BY THE YOUNG. YOUNG LEADERS CAN REACH UNPRECEDENTED NUMBERS OF THEIR PEERS WITH THEIR PROJECTS AND PROGRAMMES, INCLUDING THE PREVIOUSLY UNENGAGED AND DISADVANTAGED, GIVING A VOICE TO THE VOICELESS.



For example, a radio discussion on job opportunities revealed that many young people were unable to find work because they drop out of school and were too poor to continue their studies. The Municipality of Cape Town responded by issuing 50 scholarships to such people who wanted to continue their studies. This first response led to subsequent deeper engagement by appointing youth to serve on municipal committees and utilization of the youth network to disseminate information on municipal services to young people.<sup>8</sup>

In sum, cheap and ubiquitous cell phones and social media create a daily bond among young citizens and between youth groups and leaders. The extent to which new voices raised and opinions expressed reaches the inner workings of local government in examples like those cited here requires further investigation and assessment. Yet it seems clear that the volume of messaging leads to a rupture in the traditional codes between youth and government.

## 2. Engaging Young Citizens as Partners in Urban Governance

The upsurge in mobile phone usage has opened new avenues through which to collaborate and engage local government. In the first place, use of mobile phones has significantly increased political awareness and raised activism among young users. As one youth leader in Tanzania said, “There has been a huge difference since 2005 when young people were not very aware of their rights or their opinions regarding what should be done in their country. The spread of mobile phones has made youth more politically aware and active; most youth have social media enabled mobile phones and are using these platforms to access information and voice their opinions.”<sup>9</sup>

Youth are leading the way in utilizing technology for sharing information and generating content relevant to their lives. One expression of this trend is the development of youth-to-youth ICT platforms connecting social media, Internet and mobile phones. Such platforms can serve as a catalyst for civic engagement, encouraging young people to be proactive in building awareness about issues affecting their lives, make informed decisions, and take action. For example, young leaders in Tanzania have established an online forum, [vijaforum.org](http://vijaforum.org) (the Swahili for “youth forum.org”), as a one-stop information centre for youth, as well as an interactive discussion forum. Information necessary for the positive development of young people is posted to the site including documents, reports, news and audio files – all largely accessible through mobile phones.<sup>10</sup> Young leaders in Kenya see the access of information as an empowering agent allowing youth to “hold their head high and walk into a meeting with government officials. Knowledge is power, power is self-esteem.”<sup>11</sup>

There are signs that ICTs are beginning to provide new, constructive ways for youth to be involved in governance and government leaders to make change. In some cases, the engagement is direct and immediate. Striking examples from Rwanda, Kenya and India feature authorities reacting quickly, sometimes from the highest office, to complaints or requests posted by young activists through social media who, in turn, were energized by the attention and the responses they received. As



THE UPSURGE IN MOBILE PHONE USAGE HAS OPENED NEW AVENUES THROUGH WHICH TO COLLABORATE AND ENGAGE LOCAL GOVERNMENT. IN THE FIRST PLACE, USE OF MOBILE PHONES HAS SIGNIFICANTLY INCREASED POLITICAL AWARENESS AND RAISED ACTIVISM AMONG YOUNG USERS.



a youth leader from Kenya noted, “social media is a highway to the politicians, taking them down from their high position and bringing them nearer to us...especially when you get an answer.”<sup>12</sup> Young leaders in Sri Lanka are training municipal staff in ICT skills and creating new ICT platforms for citizen-government local interaction. This is part of a broader UN-Habitat supported programme in Kandy City called “YES - City of Youth”.

Youth are also engaged through election monitoring and watchdog roles. The Ersod Project in Yemen trained over 1,000 youth to monitor the February 2012 elections and provided a means for reporting election violations, irregularities or suspicious activity using SMS text messaging. A committee was formed to investigate reported problems and incidents were posted on an interactive map that allowed individuals to track the election online from the website.<sup>13</sup> Social media is increasing youth participation in election campaigning and engagement. The recent election in India mobilized a large number of first-time voters through social media in what was referred to as a “youthquake” that could revolutionize “forms of political engagement, the expectations from government and the political landscape itself.”<sup>14</sup>

The use of collaborative technologies is challenging traditional notions of democratic involvement by allowing youth greater opportunities to express their political will. Youth feel that they have gained more power through these tools, and that governments are beginning to show signs of being more responsive and accountable. For example, two 23-year-olds from Latvia who were frustrated by their inability to participate in the political process built an e-petition system where Latvians could submit and support proposals for new laws and other political changes. The government agreed to look seriously into any petition that got a certain amount of popular support on the platform and, according to some sources, the system has been used by at least 20 per cent of Latvians.<sup>15</sup>

ICTs can engage and motivate youth to get involved in developing and learning about their communities and thus forge increased commitment and empowerment. For instance, citizen journalism, user-generated content, and neighbourhood videos and music are attractive ways to get youth engaged in positive local development processes.





**Internet and social networks replace live communication. Three girls together chat using their smartphones outdoor.**

© Shutterstock/ Jelena Aloskina

Youth have been involved in urban planning through creative uses of digital platforms such as the “Block-by-Block” project. This initiative creates real-world environments in Minecraft, a popular online game, and lets young people who live in these environments step in and show urban planners what they would like see changed. Our interviews suggest that these activities can have a positive impact on decision makers that begin to view youth as assets in local development, and who can be leveraged to help achieve municipal objectives.

Current ICT-enabled communication between government and citizens is already having an impact on youth, making them feel more connected, engaged and heard. Even when ICT-based government initiatives are not youth-focused, young people perceive such communication as being directed primarily at their age group. As social media is considered “youth territory”, they feel that the very use of ICT channels demonstrates the government’s intention of reaching out to young people.

### 3. Public Openness through Technology

The negative impacts of corruption affect young people today, as well as their outlook for the future. The cases offer several striking examples of the need for youth to channel their creativity and innovation in the fight against corruption. ICT can empower young citizens to engage constructively in the development of new mechanisms to increase accountability and transparency, thereby contributing to good governance.

The majority of ICT applications and tools developed to follow public officials, monitor governance processes and increase public access to information is not necessarily youth-focused, but appears to be youth-driven. It seems that young technology entrepreneurs and software developers are those who are coming up with these tools and bringing them to the wider public. Young Kenyans have developed successful applications geared toward making open data information more understandable and user-friendly, including edWeb, Virtual City, and Mzalendo. In the Kyrgyz Republic, the Politmer website is being used to track the promises made by politicians during elections once they are in office. Citizens can post online those promises that they heard elected officials make in public, and these commitments are then verified, categorized and monitored by the Politmer team through the site.<sup>16</sup>

The spread of mobile phones has also empowered youth to mobilize against corruption taking the form of SMS campaigns. For example, Transparency International Zimbabwe launched a programme through which people report on bribery and corruption by sending an SMS that reaches a centre that processes the information and “takes appropriate steps to assist clients.”<sup>17</sup> This type of SMS platform is demonstrative of the power of basic mobile phones in governance processes in a country where Internet penetration is less than 12 per cent but mobile phones are accessible to most.

Young people are also harnessing the Internet to share ideas and experiences across borders in their common fight for accountability.

One of the most well-known platforms is the Global Youth Anti-Corruption Network, bringing together youth organizations, journalists and musicians from over 45 countries to fight corruption through an online social network, video conferences and face-to-face events.<sup>18</sup>

As with other ICT-enabled governance applications, it is clear that online anti-corruption programmes cannot replace traditional safeguards of good governance. Rather, they serve as a tool for increasing public participation in the fight for accountability and transparency and offer new opportunities for enhancing progress in these areas. This has particular significance for youth, who through ICTs are “sidestepping ingrained social hierarchies based on the principle of seniority”<sup>19</sup>.

#### 4. ICT Impact on Outcomes for Youth

As a large part of the population, youth benefit from general ICT-enabled services implemented by local governments such as administrative measures, transport and safety. Platforms such as Huduma in Kenya offer mobile-based communication avenues for citizens to voice, SMS or e-mail service needs or comments directly to authorities and service providers.<sup>20</sup> Similar platforms and services exist in Peru and Mexico.<sup>21</sup> However, research shows a dearth of youth-focused services. Youth face unique challenges that are specific to their stage in the life cycle and they can benefit from ICT services to enhance their opportunities in these areas. Examples might include ICT services for job placement, job readiness, entrepreneurship and e-learning. In Indonesia, the Municipality of Surabaya provides internships for high school and university students, offering an opportunity to gain experience with ICT while at the same time enabling participants to help the municipality.<sup>22</sup>

Local government ICT programmes for youth are heavily focused on ICT training. Increasingly, youth require ICT skills as part of their preparation for entering the workforce and participating in the global knowledge economy. Municipalities therefore tend to view ICT services for youth through the lens of economic empowerment, focusing on skills and access. In Kigali, capital of Rwanda, the municipality runs ICT training programmes targeting young people. “Business Development Centres” equipped with high speed Internet and ICT equipment are being set up in each of the city’s three districts as part of a national initiative to cultivate ICT usage.<sup>23</sup>

Youth organizations often help deliver these services. The Nibyiza Group, a youth NGO in Kigali focusing on ICTs, has trained over 500 youth from 40 cooperatives in the city who are finding employment or creating their own jobs. The programme has been run in collaboration with the municipality, enhancing the local government’s own services for youth.<sup>24</sup> In Cape Town, South Africa, a government programme enabling young people to access the Internet for free through a designated Internet café in the city was not being utilized due to lack of advertising and difficulties in accessing the café’s location. Working in cooperation with youth organizations, the municipality was able to raise awareness and overcome the travel challenges to improve such services.<sup>25</sup>

## Key Barriers and Challenges

### Capacity

The relative advantage of young people who have grown up with modern devices has created a “youth-local government ICT gap” that is growing steadily. The interviews provided clear evidence of a disconnect between young activists and older people holding the most responsible posts in local government. Experience with e-government services in the past has demonstrated that factors such as technological and human capacity, financial sustainability and bureaucratic resistance can limit the adoption of ICT programmes and reduce their long-term impact.<sup>26</sup> The executive director of MAP Kibera, a young leader from Kenya, said: “The reality is that most people in government are not very strong ICT users, this is something youth do better. We encourage them to blog in and respond, but a lot of them still believe in the traditional form of governance, setting meetings and sitting down together. We are trying to change this.”<sup>27</sup>

A key challenge reported by youth interviewees is the tendency of governments to limit their view of ICTs and youth to issues of access and skills. While obtaining ICT skills is of key importance in today’s market, the potential impact is much broader. Young people are interested in applying their skills to influence social, economic and political arenas. This is something that governments are still slow to understand. Youth-focused ICT programmes have emphasized skills, access and infrastructure, with little attention to how these tools can be applied to solve the problems that are of most concern to the youth.<sup>28</sup>

Another issue is the volume of traffic that mobile platforms, in particular, have brought to the relationship between the public and government. Contacts that were once annual or monthly are now daily in frequency; and the pace and volume of exchange will expand with the increased access to ICT devices. Accordingly, there is a need for greater municipal capacity in terms of staff time, skills and attention to measure, manage and take advantage of the increased flow of communications.

### Level of Government

In many cases, ICT-enabled governance in connection with youth and youth affairs has a greater impact at the national level than at the local. National government leaders are setting the example for engaging directly with citizens (especially youth) through ICTs, although this trend has not been institutionalized. Several case interviews (Rwanda, Tanzania, Gaza, Kenya, South Africa) illustrate activity where national political leaders are using Twitter accounts, blogs, SMSs and websites to engage the public, who by default end up being mostly youth. These instances materialize partly from frustration of young people whose voices are ignored or unheard by elder leaders at the local level (a sentiment echoed by all youth interviewed to date).

Rwandan President Paul Kagame is a stark example. Several instances were cited describing how he interacted with young people via Twitter and focused on concerns relating to many issues, from police violence towards youth to business ideas for urban tourism. No such possibilities currently exist for these same youth to approach the local authority with

these locally-based needs. Even more significant, President Kagame merged the national ministries of Youth and ICT in April 2012. This is a groundbreaking move both in terms of ICT and youth, with youth ministries elsewhere commonly grouped with sports or culture. However, these national developments are not reflected in the policy and practice of local government in Rwanda. The Municipality of Kigali is only beginning to plan for developing ICT tools for interaction with the public, with no specific consideration or strategy regarding youth in the context of governance.<sup>29</sup>

The irony in these findings is that modern mobile tools of communication are serving to strengthen direct communications with the centre instead of buttressing connections to decentralized governance. As long as they remain outside the ICT revolution, local governments are vulnerable to intrusions by national government. Local governments often lack policy or budgetary support from the national government when it comes to ICT-enabled governance. Accordingly, pioneering municipal officials find themselves in an uphill battle as they attempt to implement efficient, modern and responsive government.

## Key Opportunities

### Young Leadership and Youth Capacity

The research points to an emerging trend of young leadership in developing countries that offers an opportunity for the increased use of ICTs for governance and positive engagement with youth. Stakeholders view young leaders in government as the lowest hanging fruit in terms of adopting ICTs to improve local governance for youth. For instance, in Rwanda and Tanzania, it is the younger leaders and city officials who are using ICT tools to reach out and speak directly to youthful constituents using their vernacular. They can be identified as key champions in taking forward ICT-enabled urban governance for youth.

The increase in younger people occupying positions of power has contributed to a change in mindsets. The cases suggest that youth are encouraged toward civic action by the presence of strong role models. In addition, informants feel that the wider community has begun to view youth as leaders and change-makers. Young people are increasingly regarded as innovative, fast, and result-oriented. Furthermore, as the majority segment of the population, avid users of mobile platforms and innovators of new technology, it seems evident that youth will be at the forefront of the move to ICT-enabled governance.<sup>30</sup>

This opportunity is already taking shape in the way that young people are lending their skills to enhance the capacity and digital literacy of local governments as demonstrated by cases in Sri Lanka and Rwanda. In the YES – City of Youth Project in Sri Lanka, an ICT capacity gap among local officials emerged as a major barrier to overall programme progress that needed to be tackled. YES – City of Youth Project Coordinator, Poornima Meegamma, explains: “One major barrier we have is communicating with city officials who like paper and face-to-face interactions. To change this situation, we started training City Council staff on Internet, email, local language ICT and Facebook. We plan to connect city officials to citizens on a Facebook Page.”<sup>31</sup>

## Technology

Communications technologies differ greatly in the opportunities and limitations they pose for youth and local government. Mobile broadband has the most promise to increase Internet use in developing countries. While currently only available to a small percentage of people, smartphones are getting cheaper, which will increase affordability, and mobile Internet access with concomitant prospects for magnified impact on governance.<sup>32</sup> For example, in South Africa, mobile Internet users are dominated by young people, 94 per cent of whom are aged between 13 and 34. Dubbed the “Mobile Only Internet Generation”, a survey revealed that mobile Internet access is the only access method for many users across Africa.<sup>33</sup>

Social networking and user generated content are key online activities for youth, and these are logical entry points for developing effective ICT-enabled governance mechanisms for youth.<sup>34</sup> The proportion of Internet users engaging in these activities has reached very high levels, with over 70 per cent of users in Brazil, Colombia, and the Russian Federation reporting using the Internet for these purposes.<sup>35</sup> The challenge here is to understand how to use these platforms effectively for meaningful youth engagement and the conditions necessary to ensure successful implementation.

## Areas of Further Research

In processes—participation, deliberation, priority setting, and monitoring—the cases have shown that ICT has potential to be a powerful enabler to engage youth in governance decisions. However, important questions of how to best use these tools towards youth engagement goals are still being explored. There is a need to examine, expose and further develop best practices in this emerging field in order to promote effective implementation. This can be accompanied by inquiries into how successful programmes and strategies can be transferred across regions, and methodologies for measuring impact. There are many questions about gender usage, ethics and possible moral hazards on the part of cell phone providers that need attention.<sup>36</sup> More comprehensive age-specific data by region and technology needs to be developed in order to ensure effective, serious policy relating to youth participation through ICTs. Finally, initial findings point to the importance of learning more about how to make ICT-enabled governance applications relevant, attractive and exciting to engage youth effectively and the potential role they can play in designing such applications.<sup>37</sup>

## Conclusions and Policy Recommendations

Young citizens introduce an entirely new dimension to ICT and governance. The findings caution that ICT is not the answer to developing democratic institutions for youth in the developing world, but a tool that may contribute to this broader goal. Without structured channels and frameworks for youth engagement in the “physical world”, the potential of ICT may fall short for young people and for local governments. In sum, this fast-moving field is to an important extent in the hands of youth, and the development of new applications poses a challenge for local governments unlike any of the major trends in the past 40 years, including environment, gender, sustainability and good governance.

The research conducted so far suggests a number of directions that might enable greater potential benefits of ICT and accommodate the challenges it poses for youth and local government:

**1. Putting Youth and ICT in local Governance on the Agenda.**

Governance needs to be infused with a much stronger sense of the young: to account for their needs, be responsive to their concerns, and to harness their energies. Youth citizens with mobile phones are governance game changers, authors of a generational-technological revolution. Policymakers will want to gauge the stakes for governance and democratic participation by exploring the impact of these changes. Careful analysis is required to understand the conditions and proper governance frameworks that are conducive to successful youth engagement via ICTs.

**2. Extend Impact of Social Media on Local Government.**

Mobile phones connected to social media allow young people to engage local government directly. Policymakers can build on the inroads created through social networks to extend into areas of governance that have so far been impacted less by ICTs and youth, such as improving local services and increasing transparency.

**3. Capacity-building for Local Governments**

Training and capacity-building for local governments in digital communications can play a critical role in reducing the ICT capacity gap between young citizens and local government staff. Such training needs to go beyond basic ICT skills and focus on how ICTs can be harnessed for good governance and youth-focused policy outcomes.

**4. Level the Playing Field between National and Local Governments in ICT.**

In many cases, national governments are better equipped to respond to youthful concerns voiced via ICTs at the local level. National governments should be encouraged to help local governments attend to youthful concerns at the local level on their own. This may be supported by increased “decentralization” of youth/ICT strategies, bolstered by budgetary allocations and devolution of authority.

**5. Support Crowdsourced Data for Public Goods.**

Local, national, and international agencies should explore the great potential of harvesting the best of youthful contributions to local government by such means as social media, crowdsourcing and coordinated use of mobile platforms as a way to revitalize local democracy.



## References

- Anas Rawi (2012). Yemenis to Participate in SMS Election Monitoring. Yemeni Times. Retrieved 15 July. Available from <http://www.yementimes.com/en/1547/news/420/Yemenis-to-participate-in-SMS-election-monitoring.htm>.
- Brasil, T. (2012) Projeto Exelencias. Retrieved 12 August 2014. Available from <http://www.exelencias.org.br/>
- Voces Blog Post (2013). Election Bug Catches 1,000 Youth in Yemen. Retrieved 8 April 2013. Available from <http://creativevoces.com/2012/06/election-bug-catches-1000-youth-in-yemen/>
- DANIDA (2012). Using ICTs to Promote Governance: A Danida Study. Retrieved 15 July 2013. Available from <http://um.dk/en/~media/UM/English-site/Documents/Danida/Partners/Research-Org/Research-studies/Using%20ICT%20to%20Promote%20Governance%202012.ashx>
- Fitzpatrick, A. (2012). Can Youth Change the World with Technology? Retrieved 10 July 2012. Available from <http://mashable.com/2012/05/24/youth-change-world-technology/>
- International Telecommunications Union (2011). Measuring the Information Society. International Telecommunications Union. Geneva, International Telecommunications Union.
- International Telecommunications Union (2013). ICT Facts and Figures. Retrieved 15 November 2013. Available from <http://www.itu.int/en/ITU/Statistics/Documents/facts/ICTFactsFigures2013-e.pdf>
- Kubatana.net (2012). TI-Z Launches Interactive SMS Platform to Report Corruption. Retrieved 11 April 2013. Available from [http://www.kubatana.net/html/archive/cact/121105tiz.asp?sector=INFTEC&year=2012&range\\_start=1](http://www.kubatana.net/html/archive/cact/121105tiz.asp?sector=INFTEC&year=2012&range_start=1)
- Nashrulla, Tasneem (2014). Why India's Young, Urban Adults Are Finally Interested In The Elections. Retrieved 11 April 2014. Available from <http://www.buzzfeed.com/tasneemnashrulla/why-indias-young-urban-adults-are-finally-interested-in-the>
- OECD/International Telecommunication Union (2011). M-Government: Mobile Technologies for Responsive Governments and Connected Societies, Retrieved 8 August 2014. Available from <http://dx.doi.org/10.1787/9789264118706-en>
- Palvia, Jain, and Sushil Sharma (2007). E-Government and E-Governance: Definitions/Domain Framework and Status around the World. Retrieved 15 June 2014. Available from [http://www.iceg.net/2007/books/1/1\\_369.pdf](http://www.iceg.net/2007/books/1/1_369.pdf)
- Pew Research Global Attitudes Project (2014). Emerging Nations Embrace Internet, Mobile Technology. Retrieved 4 February 2014. Available from <http://www.pewglobal.org/2014/02/13/selected-age-break-tables/>
- Plan International (2010). Digital and Urban Frontiers: Girls in a Changing Landscape. Retrieved April 2013. Available from <http://www.planusa.org/becauseiamagirl/docs/becauseiamagirl2010.pdf>
- Project Ersod (2012). Project Ersod. Available from <http://ersod.org/>.
- Rao, M. (2011). Mobile Africa 2011. Retrieved July 2012. Available from <http://www.slideshare.net/momobeijing/mobile-africa-2011>.
- Secretariat of the Global Alliance for ICT and Development (2011). Youth and ICT as Agents for Change: Issues Paper. United Nations Department of Economic and Social Affairs (UNDESA). Retrieved 10 June 2012. Available from <http://unpan1.un.org/intradoc/groups/public/documents/gaid/unpan035691.pdf>.
- SMS in Action (2012). SMS in Action. Retrieved 15 July 2014. Available from <https://smsinaction.crowdmap.com/main>.
- Thompson, Briana (2012). Young and Wired. Accountability Lab. Retrieved 11 April 2013. Available from <http://bloggingonaccountability.org/2012/12/11/young-and-wired/>
- Todos Somos Dateros. (2012). Todos Somos Dateros. Retrieved 28 July 2012. Available from <http://datea.pe/info/todos-somos-dateros>.
- UN-Habitat (2012). ICT-Enabled Urban Governance in the Developing World. Quick Guides for Policymakers. Nairobi.
- United Nations Development Programme (2011). Mobile Technologies and Empowerment. Enhancing Human Development through Participation and Innovation. Retrieved July 2012. Available from [http://www.undpegov.org/sites/undpegov.org/files/undp\\_mobile\\_technology\\_primer.pdf](http://www.undpegov.org/sites/undpegov.org/files/undp_mobile_technology_primer.pdf)
- Voices Against Corruption (2012). Voices Against Corruption. Retrieved 10 July 2014. Available from <http://voices-against-corruption.ning.com/page/about-gyac>.
- World Bank (2012). ICT4D 2012: Maximizing Mobile. Retrieved 12 July 2014. Available from <http://web.worldbank.org/WBSITE/EXTERNAL/TOPICS/EXTINFORMATIONANDCOMMUNICATION/ANDTECHNOLOGIES/0,,contentMDK:23190786~pagePK:210058~piPK:210062~theSitePK:282823,00.html>.

## Annex I

### List of Interviewees

(conducted during fieldwork)

#### Saeed Mohammed Al-Dowail

President of the Assembly, Democracy Youth Society, Yemen

#### Eric Brown

Youth Coordinator  
Sustainable Cities International, Vancouver, Canada

#### Chalid Buhari

Head ICT Department, Surabaya, Indonesia

#### January Cletus

Secretary General, Tanzania Development Forum for Youth

#### Noluthando Hermanus

Project Coordinator, Khanyisa Youth Network, South Africa

#### Poornima Heshadharani

YES – City of Youth Project Coordinator, Kandy, Sri Lanka

#### Ajit Jaokar

Oxford University

#### Mthun Kumarasinghe

YES project participant, Kandy, Sri Lanka

#### Thomas Maqway

Founder and former first Chairman, Tanzania Development Forum for Youth  
Current Executive Director at Centre for Economic Prosperity

#### Walaa Mdoukh

Projects Coordinator, Palestinian Friendship Centre for Development, Gaza

#### Niranjan Meegammana

Project Director & Chief Technologist, Shilpa Sayura Foundation, Sri Lanka

#### Vincent Mikuru

MAP Kibera

#### Eva Clemente Miranda

Transport Water and Urban and Information Technology  
World Bank

#### Oliver Mugame

Former Vice Mayor, Finance and Economics, Municipality of Kigali

#### Phillemon Mutashubirwa

Programme Manager, UN-Habitat, Tanzania

#### Jean Philbert Nsengimana

Minister of Youth & ICT, Government of Rwanda

#### Kepha Ngito

Executive Director, MAP Kibera

#### Charles Rusimbi

Manager of Youth, Sports and Culture, City of Kigali

#### Martin Ruvugabigw

Executive Director, Nibyiza Group, Kigali, Rwanda

#### Sangwa Rwabuhuhi

President and Founder, Nibyiza Group, Kigali, Rwanda

#### Hon. Jerry Silaa

Mayor, Ilala Municipal Council, Dar es Salaam City, Tanzania

#### Giuliano Stiglitz

CEO, Orange Advertising Americas - France Telecom Group

#### Cedric Umuhire

ICT Systems Management Unit Director, City of Kigali, Rwanda

#### Roxana Widmer-Iliescu

Senior Programme Officer, ITU

#### Srinivas Chary Vedala

Executive Director, Administrative Staff College, Hyderabad, India

#### Mahmoud Zant

Executive Manager, Palestinian Friendship Centre for Development, Gaza

## Annex II

### Consultations

(Feedback and reflections on cases and full document)

#### Youth Consultations

##### Anette Arneberg

Member of Oslo Youth Council

##### Joanne Kariuki

Executive Director, YouthAlive! Kenya

##### Balder Bryn Morsund

Vice President of Oslo Youth Council

##### Chris Muthuri

Partnerships and Institutional Development Officer, Youth Alive! Kenya

##### Sigri Stokke Nilsen

Coordinator for Young Participation at UngOrg, City of Oslo, Norway

##### Ida Ragnarsson

Programme Manager, National Council of Swedish Youth Organizations

##### Andreas Sveta

President, Oslo Youth Council

##### Viktor Orri Valgarðsson

National Youth Council of Iceland

#### International Telecommunication Union

##### Doug Court

Broad Band Commission for Digital Development & Junior Analyst, ITU

##### Nicolas Jammes

Project Coordinator, ITU-Global Girls in ICT Day Project

##### Roxana Widmer-Iliescu

Senior Programme Officer, ITU

## Annex III

## Fifty Cases – Youth, ICT &amp; Local Governance

NO.	AREA OF GOVERNANCE	COUNTRY	TYPE	CASE	REFERENCE
1	1 Balancing inclusiveness and responsiveness	UK	b>y	Apps for Good - offers unemployed youth a free training course on how to design, code and build social apps.	<a href="http://mashable.com/2012/04/18/facebook-apps-for-good/">http://mashable.com/2012/04/18/facebook-apps-for-good/</a>
2	1 Balancing inclusiveness and responsiveness	West Bank	n>y	Ruwvad ICT youth programmes provide ICT instruction, social networking and engagement via ICTs. Developed online Palestinian Youth Portal	<a href="http://www.ruwvad.org/index.php?rt=SitePages/ICTYouthProgramming">http://www.ruwvad.org/index.php?rt=SitePages/ICTYouthProgramming</a>
3	1 Balancing inclusiveness and responsiveness	India	y>g	Smart Vote - (Bangalore Political Action Committee) Using IT and mobile phones for voting registration participation, driven by and focusing on youth.	<a href="http://www.smartvote.in/">http://www.smartvote.in/</a>
4	1 Balancing inclusiveness and responsiveness	Madagascar	g>y	Governance by mobile. National government with international and local cell phone providers encourage participation by youth to provide inputs in development policy.	<a href="https://www.undpegov.org/featured/Madagascar">https://www.undpegov.org/featured/Madagascar</a>
5	1 Balancing inclusiveness and responsiveness	Nepal	n>y	Voices of Youth teens using Text messages (SMS via toll free mobile number) for self-expression and peer support on a radio show heard by 6.3 million youth.	<a href="https://smsinaction.crowdmap.com/reports/view/137">https://smsinaction.crowdmap.com/reports/view/137</a>
6	1 Balancing inclusiveness and responsiveness	Uganda	n>y	Ureport - through SMS and radio young “social monitors” are sent regular polls, gather data on community services and issues, and receive useful facts for action and advocacy.	<a href="http://www.unicef.org/infobycountry/uganda_62001.html">http://www.unicef.org/infobycountry/uganda_62001.html</a>
7	1 Balancing inclusiveness and responsiveness	Global	g>y	Girls & ICT Programme - portal to create awareness for young girls of opportunities that ICT education and career development can offer.	Interview with Roxana Widmer-Liescu, ITU <a href="http://girlsini.org">http://girlsini.org</a>
8	1 Balancing inclusiveness and responsiveness	19 countries	y>c	Participation 3.0 - Fosters development of Internet-based technologies to improve local participation and transparency in government-community affairs.	<a href="http://pages.e-democracy.org/Participation_3.0">http://pages.e-democracy.org/Participation_3.0</a>
9	1 Balancing inclusiveness and responsiveness	Philippines	g>y	Checkmyschool.org – students use social media (Facebook and Twitter) and SMS to comment, monitor and evaluate their schools and inform the public.	<a href="http://www.checkmyschool.org">www.checkmyschool.org</a>
10	1 Balancing inclusiveness and responsiveness	USA	n>c	Code for America recruits young graduates to serve as interns with local authorities to create web-based improvements for access by citizens and functioning of government.	<a href="http://www.Codeforamerica.org">http://www.Codeforamerica.org</a>
11	1 Balancing inclusiveness and responsiveness	Philippines	n>y	eSkwela Project - provide ICT-enhanced educational opportunities for Filipino out-of-school-youth and adults.	<a href="http://eskwela-apc-nstp.wikispaces.com/about+the+project">http://eskwela-apc-nstp.wikispaces.com/about+the+project</a>
12	2 Engaging Citizens as Partners in Urban Governance	Rwanda	g>y	Mobile App Challenge (for jobs) Rwanda’s Ministry of Youth and ICT, and the UNDP, in close collaboration with Motorola Solutions, deployed a Mobile App Challenge implemented by YouthConnekt, aimed at young entrepreneurs to promote job creation and youth empowerment.	<a href="http://www.biztechafrica.com/article/youthconnekt-launches-mobile-apps-human-development/7718/#.U6CTX_IdWSq">http://www.biztechafrica.com/article/youthconnekt-launches-mobile-apps-human-development/7718/#.U6CTX_IdWSq</a>
13	2 Engaging Citizens as Partners in Urban Governance	Ghana, Zimbabwe, others	g>y	Health Education Text by SMS developed by texttochange is employed by Savannah Signatures, and NGO to promote education in sexual health in Ghana. Similar programmes have been launched in other countries.	<a href="http://www.texttochange.org/news/simple-sms-provides-young-people-ghana-sexual-health-education">http://www.texttochange.org/news/simple-sms-provides-young-people-ghana-sexual-health-education</a>
14	2 Engaging Citizens as Partners in Urban Governance	Brazil	n>y	Mapa Falante (speaking map) CEDAPS (Centro de Promocao da Saude—Centre for Health Promotion) an NGO, employs mapping techniques to gather information about community health needs by those who know them best: the residents. Tools include mobile phones and the Internet. In related activities, teenagers use digital cameras sitting in old bottles, which are launched via kites to take pictures of specific danger points in favelas, where rubbish heaps can turn into a home for mosquitoes carrying dengue fever.	<a href="http://www.cedaps.org.br/portfolio/mapeamento-participativo-do-territorio-mapa-falante/">http://www.cedaps.org.br/portfolio/mapeamento-participativo-do-territorio-mapa-falante/</a>
15	2 Engaging Citizens as Partners in Urban Governance	India	g>c	The rise of social media, increase in first-time youthful voters, and demand for social justice are producing a “youthquake” in electoral campaigning and engagement.	<a href="http://www.buzzfeed.com/tasneemnashrulla/why-indias-young-urban-adults-are-finally-interested-in-the">http://www.buzzfeed.com/tasneemnashrulla/why-indias-young-urban-adults-are-finally-interested-in-the</a>

NO.	AREA OF GOVERNANCE	COUNTRY	TYPE	CASE	REFERENCE
16	2 Engaging Citizens as Partners in Urban Governance	Kenya, Haiti, Nepal	g>c	Block by Block Design. Software sponsored by Minecraft and local partners asks young community members to redesign public spaces by using a popular sandbox game that allows players to build anything within the limits of their imaginations.	<a href="http://www.Blockbyblock.org">http://www.Blockbyblock.org</a>
17	2 Engaging Citizens as Partners in Urban Governance	Canada	g>y	Youth Vital Signs - youth vital signs report makes use of questions pushed a cell phone. Has worked well. City checks data.	Youthvitalsigns.ca
18	2 Engaging Citizens as Partners in Urban Governance	Gaza	y>c	Young Reporters for Citizenship – trains youth on issues of citizenship and media to impact key local and national issues	Interview with Palestinian Friendship Centre for Development <a href="http://tinyurl.com/d373puu">http://tinyurl.com/d373puu</a>
19	2 Engaging Citizens as Partners in Urban Governance	Ghana	n>y	Ghana Decides - foster a better-informed electorate for free, fair and safe 2012 elections using online social media tools, focusing on youth	<a href="http://ghanadecides.com/">http://ghanadecides.com/</a>
20	2 Engaging Citizens as Partners in Urban Governance	Kenya	n>c	Huduma - mobile-based communication avenues for citizens to voice, SMS or email service needs or comments directly to authorities and service providers	<a href="http://www.huduma.info/">http://www.huduma.info/</a>
21	2 Engaging Citizens as Partners in Urban Governance	Latvia	y>c	Latvian E-Petition - two 23-year-olds built an e-petition system where Latvians could submit and support proposals for new laws and other political changes.	<a href="http://mashable.com/2012/05/24/youth-change-world-technology/">http://mashable.com/2012/05/24/youth-change-world-technology/</a>
22	2 Engaging Citizens as Partners in Urban Governance	Peru	g>y	Todos Somos Dateros (we are all information providers) Online and cell enabled system for citizens to voice their concerns aggregating these concerns and channeling them to city-level decision makers	<a href="http://techpresident.com/news/wegov/23520/peruvian-ngo-discovers-fatal-weakness-civic-participation-platforms">http://techpresident.com/news/wegov/23520/peruvian-ngo-discovers-fatal-weakness-civic-participation-platforms</a>
23	2 Engaging Citizens as Partners in Urban Governance	UK	n>y	Riot Clean Up – new Twitter handle mobilizing social media for community re-building and clean-up efforts following riots.	<a href="http://thenextweb.com/twitter/2011/08/12/act-ii-london-taps-twitter-and-facebook-to-help-re-build/">http://thenextweb.com/twitter/2011/08/12/act-ii-london-taps-twitter-and-facebook-to-help-re-build/</a>
24	2 Engaging Citizens as Partners in Urban Governance	Madagascar	g>y	M-Governance Platform for Youth - supports youth participation in discussions about development in Madagascar using mobile tools based on SMS.	<a href="http://www.undpegov.org/sites/undpegov.org/files/undp_mobile_technology_primer.pdf">http://www.undpegov.org/sites/undpegov.org/files/undp_mobile_technology_primer.pdf</a>
25	2 Engaging Citizens as Partners in Urban Governance	Afghanistan	g>c	National Elections - Large youth voter base has led to campaigning via social media and mobile technology for the first time in Afghan electoral history. Young people constituted 70% of provincial council candidates across the country.	<a href="http://www.theatlantic.com/international/archive/2014/04/the-newfound-political-power-of-afghan-youth/360216/">http://www.theatlantic.com/international/archive/2014/04/the-newfound-political-power-of-afghan-youth/360216/</a>
26	2 Engaging Citizens as Partners in Urban Governance	Rwanda	g>c	#MinisterMondays Twitter chats - Rwanda's health minister responds to every tweet received during chats held every other Monday; SMS channel integrated for those with simple phones.	<a href="http://tinyurl.com/blc4ntb">http://tinyurl.com/blc4ntb</a>
27	2 Engaging Citizens as Partners in Urban Governance	Pakistan	g>y	Sanitation Hackathon – students developed mobile- and web-based applications for water and sanitation utilities in Pakistan.	<a href="http://blogs.worldbank.org/endpointityinsouthasia/node/786">http://blogs.worldbank.org/endpointityinsouthasia/node/786</a>
28	2 Engaging Citizens as Partners in Urban Governance	Rwanda	y>c	IGIHE.COM - Youth-created national online news portal - provide news, people posting feedback and twitter with comments on current events	Interview with Olivier Mugame, Former Vice Mayor, Kigali, <a href="http://igihe.com/">http://igihe.com/</a>
29	2 Engaging Citizens as Partners in Urban Governance	Rwanda	y>y	Nibyiza Group - Initiates projects to create new opportunities for thousands of youth in Rwanda through ICT.	Interview with Sangwa Rwabuhiri, Interview with Cedric Umuhire, ICT, Manager, City of Kigali <a href="http://www.youthrwanda.org">http://www.youthrwanda.org</a>
30	2 Engaging Citizens as Partners in Urban Governance	South Africa	y>y	Drive Out Philippi Radio - using radio to communicate with youth through a local radio station connected to social media and mobile phones	Interview with Khanyisa Youth Network
31	2 Engaging Citizens as Partners in Urban Governance	Tanzania	y>y	Vijanaforum.org - online platform by and for youth with information sharing centre and discussion forum for youth to voice their views and organize.	Interview, Tanzania Development Forum for Youth, <a href="http://www.vijanaforum.org">http://www.vijanaforum.org</a>
32	2 Engaging Citizens as Partners in Urban Governance	Tanzania	g>c	Open Governance Initiative Young people were successful in uniting to advocate a freedom of information bill in response to national government call for views of citizens in drafting country strategy document.	Interview with Thomas Maqway
33	2 Engaging Citizens as Partners in Urban Governance	Global	n>y	One Young World - a non-profit organization that provides an open platform for young people to create positive change.	<a href="http://mashable.com/2011/09/19/one-young-world-social-good-summit/">http://mashable.com/2011/09/19/one-young-world-social-good-summit/</a>

NO.	AREA OF GOVERNANCE	COUNTRY	TYPE	CASE	REFERENCE
34	2 Engaging Citizens as Partners in Urban Governance	Yemen	n>y	Ersod Project - youth trained to monitor elections and provide a means for reporting election violations, irregularities using SMS text messaging.	<a href="https://smsinaction.crowdmap.com/reports/view/201">https://smsinaction.crowdmap.com/reports/view/201</a>
35	3 Public Openness	Global	y>c	Global Youth Anti-Corruption (GYAC) - global network of young leaders, journalists, artists and ICT experts from civil society who work to improve transparency for better governance.	<a href="http://voices-against-corruption.ning.com/page/about-gyac">http://voices-against-corruption.ning.com/page/about-gyac</a>
36	3 Public Openness	Global	b>y	Mobile Alliance - association of worldwide mobile operators that works with governments and governing bodies to protect youth and young people from being exploited on mobile devices.	<a href="http://www.gsma.com/publicpolicy/myouth/mobiles-contribution-to-child-protection/mobile-alliance/">http://www.gsma.com/publicpolicy/myouth/mobiles-contribution-to-child-protection/mobile-alliance/</a>
37	3 Public Openness	India, Kenya	n>c	I paid a bribe - Web sites and video cams capture and curate stories about corruption.	<a href="http://www.ipaidabribe.com/">http://www.ipaidabribe.com/</a>
38	3 Public Openness	Philippines	y>c	Cell phone Ringtone - Recorded phone conversation alleged to be between Gloria Arroyo and election official - became popular cell phone ringtones after made public, especially among the youth.	<a href="http://en.wikipedia.org/wiki/Hello_Garci_scandal">http://en.wikipedia.org/wiki/Hello_Garci_scandal</a>
39	3 Public Openness	Kenya	y>c	MAP Kibera - ICT media mapping technology to encourage more participation of people in community, engage citizens in mapping.	Interview with MAP Kibera <a href="http://mapkibera.org/">http://mapkibera.org/</a>
40	3 Public Openness	Uganda	y>c	War Child SMS-based campaign against corporal punishment - Text messages to stop abuse and corporal punishment of youth and children.	<a href="https://smsinaction.crowdmap.com/reports/view/176">https://smsinaction.crowdmap.com/reports/view/176</a>
41	3 Public Openness	Kyrgyz Republic	y>c	Poltimer website - used to track the promises made by politicians during elections once they are in office.	<a href="http://politmer.kg/ru">http://politmer.kg/ru</a>
42	3 Public Openness	Brazil	n>c	Excelencias - developed by Transparency International Brazil and widely used by journalists to increase accountability through reporting; provides open access to public information at various levels of government.	<a href="http://www.excelencias.org.br/">http://www.excelencias.org.br/</a>
43	3 Public Openness	Zimbabwe	n>c	SMS Reporting on Corruption - Transparency International Zimbabwe programme people report on bribery and corruption by sending an SMS that reaches a centre that processes the information and takes action.	<a href="http://www.kubatana.net/html/archive/cact/121105tiz.asp?sector=INFTEC&amp;year=2012&amp;range_start=1">http://www.kubatana.net/html/archive/cact/121105tiz.asp?sector=INFTEC&amp;year=2012&amp;range_start=1</a>
44	3 Public Openness	Tunisia	n>y	Parliamentary Marsad (observatory) Interactive website tracks and provides updates on activities of Tunisian parliament, allowing citizens to questions officials. Questions and answers are moderated by nonpartisan group.	<a href="http://techpresident.com/news/wegov/24936/people%27s-marsad-tunisian-parliament#.U1kn336qZEQ.twitter">http://techpresident.com/news/wegov/24936/people%27s-marsad-tunisian-parliament#.U1kn336qZEQ.twitter</a>
45	4 Adopting technology to improve outcomes	Indonesia	g>y	Surabaya Municipality Internship Programme - internships for high school and university students to gain experience with ICT and help the municipality.	Interview with head of ICT department, Municipality of Surabaya
46	4 Adopting technology to improve outcomes	Indonesia	g>c	Broadband centres in strategic locations in the city allow citizens to learn about the Internet, emails, blogging, as well as other educational or job-specific applications in scheduled classes.	Interview with head of ICT department, Municipality of Surabaya
47	4 Adopting technology to improve outcomes	Many countries	n>y	m2Work (mobile microwork) - aims to expand microwork to the 5 billion mobile phones in the developing world.	<a href="http://www.ideasproject.com/community/en/treasury/m2work">http://www.ideasproject.com/community/en/treasury/m2work</a>
48	4 Adopting technology to improve outcomes	Senegal	y>c	Jokko Initiative, Tostan NGO - community-wide democracy and empowerment programmes integrating SMS texting as part of overall education and literacy.	<a href="http://www.tostan.org/web/page/599/sectionid/548/pagelevel/2/interior.asp">http://www.tostan.org/web/page/599/sectionid/548/pagelevel/2/interior.asp</a>
49	4 Adopting technology to improve outcomes	Sri Lanka	y>g	Youth Empowerment Society (YES) City of Youth - helps youth explore digital resources and employs these tools to change the city.	Report & Interview, Project Coordinator Poornima Meegammana <a href="http://www.kandy-youth.org">www.kandy-youth.org</a>
50	4 Adopting technology to improve outcomes	South Africa	g>y	eThekwini Municipality community asset mapping pilot projects with youth in 2 communities, youth explored sustainability features of their community, sites collected and put on the municipality's online Green Map.	<a href="http://www.imaginedurban.org/sites/Blog/default.aspx">http://www.imaginedurban.org/sites/Blog/default.aspx</a>

## Endnotes

1. UN-Habitat, 2012. "Quick Guides for Policymakers (second series) ICT-enabled Urban Governance in the Developing World" Nairobi: UN- Habitat.
2. Interview with Sangwa Rwabuhuhi, President and Founder, Nibiza Group, Kigali, Rwanda, July 2012.
3. Interview with Hon. Jerry Silaa, Mayor, Ilala Municipal Council, Dar es Salaam City, Tanzania, December 2012.
4. Available from [http://www.unicef.org/infobycountry/uganda\\_62001.html](http://www.unicef.org/infobycountry/uganda_62001.html)
5. Roxana Widmer-Iliescu, Senior Programme Officer ITU, Consultation, November 2012.
6. Chris Muthuri, YouthAlive! Kenya, Consultation November 2012.
7. This is a UNICEF initiative implemented with local NGOs, for more information see: <https://smsinaction.crowdmap.com/reports/view/137>
8. Interview with Noluthando Hermanus, Project Coordinator, Khanyisa Youth Network, South Africa, November 2012.
9. Interview with Thomas Maqway, Founder and Executive Director of the Centre for Economic Prosperity; Founder and former first Chairman, Tanzania Development Forum for Youth, July 2012.
10. Interview with January Cletus, Secretary General, Tanzania Development Forum for Youth, December 2012. Available from <http://www.vijanaforum.org/infocentre/>
11. Interview with Kepha Ngito, Executive Director, MAP Kibera, July 2012.
12. Chris Muthuri, YouthAlive! Kenya, Consultation, November 2012.
13. "Yemenis to Participate in SMS Election Monitoring," Yemeni Times, Anas Rawi, 16 February 2012. Retrieved July 2012 Available from <http://www.yementimes.com/en/1547/news/420/Yemenis-to-participate-in-SMS-election-monitoring.htm>. See also "Election Bug Catches 1,000 Youth in Yemen," June 25, 2012 Creative Voices. Retrieved 8 April 2013. Available from <http://creativevoices.com/2012/06/election-bug-catches-1000-youth-in-yemen/> .
14. See Nashrulla, 2014. Can Youth Change the World with Technology?, Alex Fitzpatrick, Mashable.com, 24 May 2012.
15. Available from <http://mashable.com/2012/05/24/youth-change-world-technology/>
16. <http://politmer.kg/>
17. TI-Z launches interactive SMS platform to report corruption, Kubatana.net, 5 November 2012. Retrieved on 11 April 2013. Available from [http://www.kubatana.net/html/archive/cact/121105iz.asp?sector=INFTEC&year=2012&range\\_start=1](http://www.kubatana.net/html/archive/cact/121105iz.asp?sector=INFTEC&year=2012&range_start=1)
18. <http://voices-against-corruption.org>
19. Young and Wired, Briana Thompson, Accountability Lab, 11 December 2012. Retrieved 11 April 2013. Available from <http://bloggingonaccountability.org/2012/12/11/young-and-wired/>
20. <http://www.huduma.info/>
21. <http://datea.pe/info/todos-somos-dateros>
22. Interview with Surabaya Municipality, June 2012.
23. Interview with Cedric Umhire, ICT Manager of the Municipality of Kigali, July 2012 and interview with Chalid Buhari, Head ICT Department, Surabaya Municipality, Indonesia July 2012.
24. Interview with Charles Rusmbi, Manager of Youth, Sports and Culture, City of Kigali, December 2012. Training took place in the Kigali Kimisagara One Stop Youth Employment and Productive Centre.
25. Interview with Noluthando Hermanus, November 2012.
26. "Maximizing Mobile", World Bank, 2012, p. 94.
27. Interview with Kepha Ngito, July 2012.
28. Interview with Sangwa Rwabuhuhi, December 2012.
29. Interview with Cedric Umhire, July 2012.
30. This conclusion is confirmed by the Secretariat of the Global Alliance for ICT and Development, UNDESA in its issue paper Youth and ICT as Agents for Change. Available from <http://unpan1.un.org/intradoc/groups/public/documents/gaid/unpan035691.pdf>
31. Interview with Poornima Meegammana, Project Coordinator, YES – City of Youth, Kandy Sri Lanka November 2012.
32. Low-cost semiconductor technology has pushed down the price of a basic smartphone to below \$100 in emerging markets over the past year.
33. Mobile Africa Report 2011, Dr. Madanmohan Rao, MobileMonday, March 2011. Retrieved from: slide/ page 34. Available from <http://www.slideshare.net/momobeijing/mobile-africa-2011>
34. "Social networking and user-created content are now among the main online activities in which young people especially (who constitute the majority of the population in developing countries) are actively engaging..." Measuring the Information Society 2011, ITU, Geneva Switzerland, p.3.
35. Ibid.
36. Interview with Roxana Widmer-Iliescu, Senior Programme Officer, ITU, July 2012 and Nicolas Jammes, Project Coordinator, ITU-Global Girls in ICT Day Project, Consultation, November 2012. Also see Digital and Urban Frontiers: Girls in a Changing Landscape, Plan International 2010. Retrieved April 2013. Available from <http://www.planusa.org/becauseiamagirl/docs/becauseiamagirl2010.pdf> .
37. Interview with Giuliano Stiglitz, CEO, Orange Advertising Americas - France Telecom Group July 2012 and Sigri Stokke Nilsen, Coordinator for Young Participation at UngOrg, City of Oslo, Norway, Consultation, October 2012.







# “City Changer Labs and Digital Civics”

○ Alfonso Goveia  
Mexico

## Abstract ○

People are the drivers of cities. Their creativity can be mobilized in a comprehensive and participatory planning process that fosters social cohesion, and opens up social paths of change to better prepare citizenship for the upcoming, unprecedented urban growth. “Digital civics”, a UN-Habitat initiative, mediates citizens’ interactions through platforms of

knowledge, ecosystems of interaction, and interfaces for governance. One of its prototype projects, City Changer Labs, engages youth to solve urban problems with mobile innovation and entrepreneurship in order to become technologically empowered and socially contextualized citizens<sup>1</sup>.

### Keywords:

ICT, Governance, Youth, Innovation, Entrepreneurship, Mobile Technology, Living Labs, City Changer Labs, Digital Civics,

## Introduction

Cities will expand and mutate at unprecedented ranges and rates. By year 2050, 2.7 billion more inhabitants will demand a three-fourths increase of all existing urban stock<sup>2</sup>. The need to house this population, build and operate physical infrastructures, and provide urban services cannot be met in the next 35 years without substantial changes in the ways people behave and engage in public life.

Traditionally, social institutions arose and adapted slowly to old pre-existing urban forms and transforming them while discovering new urban configurations. In an era of digital connectivity, accelerated city growth has to consider, now, alternative ways for citizenship to be the cause and effect of new city structures. People are the producers of, rather than the consumers of, cities. So, innovative relationships between individuals and governments are needed to make major political transformations in civic life at digital spaces and at places<sup>3</sup> in the cities.

Nowadays technological solutions promote a paradigm of intelligent urban development, or “smarter”<sup>4</sup> infrastructure, to become more sustainable and resilient. However, there is still much to do for city residents in order to increase equity in development, equal access opportunities to knowledge and communication, and to open up the creation of innovative governance and social infrastructure<sup>5</sup>. New levels of participatory action, investments in social capital and prudent management of resources are needed in order to solve some of the most complex problems currently facing cities<sup>6</sup>.

Digital civics provides basic principles that can be used as a conceptual framework to understand the growing field of smart cities. The initiative can also guide policy formulation, programmes and projects by which residents can interact with their environments and among themselves using digital tools.

As part of this initiative, City Changer Labs engage youth to solve urban issues through innovation and entrepreneurship in mobile technology.

## Background

The world is young, urban, mobile, increasingly digital, but still unequal. Half of its population is under the age of 30<sup>7</sup> and live in cities.<sup>8</sup> Global penetration of cellular phone subscriptions has reached 96 per cent<sup>9</sup> of the world's city inhabitants, one-third of society use the Internet<sup>10</sup> but one-fifth still exist below the internationally determined poverty line of USD2 per day.

Making youth partners in development can help ease their transition to productive citizens. After all, youths are key agents for economic growth and technological innovation. When empowered to play a vital role they shape the process and the outcome of personal and communal development<sup>11</sup>.

Working for youth as beneficiaries, engaging them as partners, and supporting them as leaders can help appreciate and mobilize their talents, and reduce their vulnerability to unstable environments.<sup>12</sup> It

will also increase their absorption into the job market and, as a result, build a stronger economic base that reverse poverty trends<sup>13</sup>. There is a strategic urgency to raise the human capital of youth through education and training, to help them become more productive during their working years<sup>14</sup>.

Daniella Ben-Attar and Tim Campbell<sup>15</sup> have identified a framework for youth and ICT-enabled governance. Their research shows how mobile platforms, the most important ICT tools that affect youth, can enhance their engagement in local government affairs and foster inclusiveness and responsiveness. Through crowdsourcing, georeferencing and communication networks youth are leading the way in political participation.

A natural enabling environment for promoting youth and governance are hackathons. These are events for software development. The name blends the words “hack” and “marathon”. The first refers, in today's dictionaries, to playful and exploratory programming, dealing with something successfully in a quick and inelegant manner, clearing one way, figuratively speaking, through metaphorical jungles. The second expresses a common practice in software development: marathon bursts of coding.

As Steve Levy explains; historically, “hack” in old Massachusetts Institute of Technology (MIT) lingo, meant a feat imbued with innovation, style and technological virtuosity. Within this context hackers are adventurers, visionaries, risk takers, and artists, conscious that one could go infinitely far by immersion in the deep concentration of the hacking mindset. Their philosophy of sharing, openness, decentralization, and hands-on experience aims to improve machines and the world at large. From the true innovators at the MIT Artificial Intelligence Lab in the 1950s and 1960s, to the populist Californian coders of the 1970s, to the programmers of the 1980s, Levy shows how hackers believe they understand machines at its most profound level, and how their quests have written the real story of the computer revolution<sup>16</sup>.



CITY CHANGER LABS OFFER A RESPONSE TO THESE TWO UNATTENDED NEEDS: RELEVANT URBAN CHALLENGES, THROUGH COMMUNAL DEFINITION WITH THE HELP OF UN-HABITAT'S GLOBAL KNOWLEDGE OF URBAN ISSUES, AND A NEW PIPELINE FOR INNOVATION AND ENTREPRENEURSHIP THAT ACCELERATES THEIR PROPOSALS INTO COMMERCIAL PRODUCTS AND OPPORTUNITIES FOR YOUTH ENTREPRENEURSHIP.



In the past two years hackathons have exploded as marathon coding competitions to pitch, programme and present functional application prototypes developed in a few hours. With them has come a wave of innovation, entrepreneurship as well as new opportunities to network, learn, and test ideas and technological solutions. For the ICT industry and venture capitalists, hackathons are an ideal way to recruit talent and discover good ideas for funding<sup>17</sup>.

Hackathons build upon another important method: agile software development<sup>18</sup>. Agile methodology primes prototypes and iterations. As Manifesto for Agile Software Development proclaims, it values individuals and interactions, as well as collaboration and response to change. It believes that the best software architectures, requirements and designs emerge from self-organizing teams. With new ICT tools and resources, hackathons can help catalyze the new philosophy of “now-ist” or “Deploy or Die” of Joi Itto<sup>19</sup> and “focus on being connected, always learning, fully aware, and super present”.

Hackathons, however, frequently miss pertinent social challenges and lack continuity to support development of their application prototypes. City Changer Labs offer a response to these two unattended needs: relevant urban challenges, through communal definition with the help of UN-Habitat’s global knowledge of urban issues, and a new pipeline for innovation and entrepreneurship that accelerates their proposals into commercial products and opportunities for youth entrepreneurship.

## Digital Civics

The hackathons of City Changer Labs happen within the framework of “digital civics”, the UN-Habitat initiative to support effective citizenship and governance to better prepare for expected city growth.

The purpose of digital civics is to put people first, engage citizens in collective action, to empower their awareness, decision-making, tactical influence and the construction of new social paths for change, which will in turn prepare cities for the future challenges they will face.

People are the real drive of cities and their transactions are at the heart of urban life. How they connect, relate and act create those networks of interactions that Manuel Castells calls the space of flows in the space of places<sup>20</sup>. We could well think of these transactions as the synapses of cities, and call those clefts where their sparks happen “the space of interfaces”. That is the connecting points where people link activities into issues circulating through the nodes of the space of flows.

Digital civics works at this space of interfaces, considering technology as part of a larger scope of human activities that occur in a social context, influencing work and tools applied to reach particular goals. Emphasis is on interaction between human actors and their shared contexts; understanding, as in Activity Theory<sup>21</sup>, that tools shape the way we interact with reality, and usually reflect the accumulation and transmission of social knowledge<sup>22</sup> over time.

Complementary to smart cities that rely on sensing, digital civics rely on acting. Sensors, networks and analytics are the main elements of

smart cities, while the components of this new initiative are people in communities that share norms, a clear division of labour, precise tools and common goals for collective action.

Traditionally, civics involves the study of citizenship: educating citizens about their rights and duties, their role in the choice of a form of government, with its operation and oversight; about ethics in public life, the adoption of legal codes, the application of justice, the control of legal systems; the processes of governance, the balance of power; and even the desired kind of state. New digital resources transform these civic activities and allow communities to engage in dialogue, make decisions, translate expectations into policy and monitor compliance. There are plenty of opportunities to empower citizens to identify relevant issues, understand the implications of their solutions and respond with concrete actions.

Four goals guide digital civics: foster social cohesion – as mission; promote openness and transparency - as vision; work with comprehensive participatory planning - as instrument; and use ICT - as media.

Three layers of components form digital civics: knowledge platforms, ecosystems of interactions, and interfaces for governance. Platforms for knowledge structure a field of expertise for open collaboration. Ecosystems of interaction engage citizens in collective action. interfaces of governance orchestrate flows of interchange.

Figure 1. Digital Civics

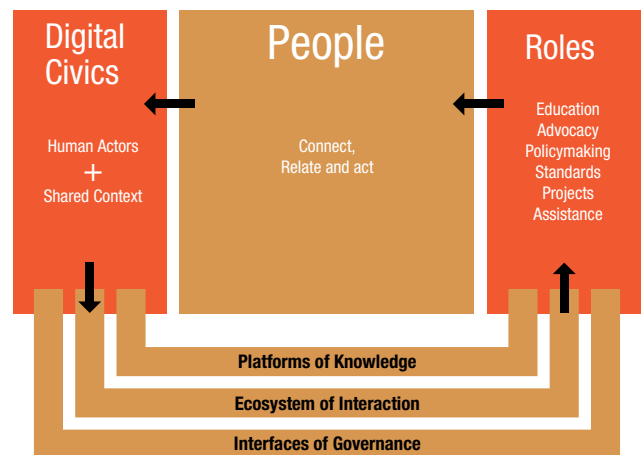

Platforms for knowledge order data, analytics, visualization and collaboration tools. A particular field of knowledge orders its information, complements its analysis with predefined functional operations, provides standard means to visualize its results, and promotes cooperation among its community of users and working groups. Open data movement is a well-known example of a platform of knowledge where data is structured to be freely available to everyone without restrictions from any mechanism of control. Others examples include the United Nations Sustainable Development Knowledge Platform<sup>23</sup>, or the Green

Growth Knowledge Platform by the Global Green Growth Institute, the Organisation for Economic Co-operation and Development, the United Nations Environment Programme and the World Bank<sup>24</sup>; or, more generally, application programming interfaces that provide databases, software components and their interaction for open software development in a specific field, like Maps API for Google Developers.

UN-Habitat-Mexico has started to develop knowledge platforms for its own programmes, in particular the City Prosperity Index, Safer Cities and the City Resilience Profiling Programmes.

Creating knowledge platforms opens up the possibility for “ecosystems of interaction” to engage the public in co-creation and cooperative work that sparks innovation and entrepreneurship. They do so by providing enabling environments where stakeholders can use predefined toolkits to set common goals and to solve clear urban problems. These ecosystems of interaction can take many forms that range from training and capacity-building experiences, online educational opportunities; to living laboratories, open-hardware events, fabrication laboratories (or fab labs); or artistic hacker spaces, entrepreneurial workshops, boot camps, conferences or competitions. UN-Habitat-Mexico has explored two examples of ecosystems of interaction; the first is the City Changer Labs, showing how to engage youth to solve urban issues with mobile technology. The second is the Block-by-Block<sup>25</sup> competition at Aldea Digital 2014 in the Zocalo of Mexico City. This is the main square where 7,500 children came out to play with Minecraft to learn how public space is built, and collected 431 complete children projects for Plaza Tlaxcoaque in the Downtown Historic District.

Interfaces of governance coordinate flows of interactions, with digital and collaborative resources that promote massive engagement and collaborative action. For example, the largest inclusive planning process under way with the United Nations Global Survey for a Better World lets citizens vote their priorities for the global agenda of developmental issues. A proposal is under way to link these priorities to ecosystems of interaction for global mass collaboration<sup>26</sup> This conceptual framework of knowledge platforms, together with ecosystems of interactions and interfaces of governance can be useful in understanding the multitude of initiatives being promoted worldwide by the “smart city” movement, and serve as a preliminary search for potential actions for a new form of citizenship.

The social relevance of digital civics consists in making knowledge open and collaborative, interactions possible in diverse tool-making environments, with governance always in control of public rule-making opportunities.

### City Changer Labs

City Changes Labs began two years ago as part of the UN-Habitat campaign I’m a city changer<sup>27</sup>, and also aligned with the agency’s other thematic priorities such as governance under the Urban Legislation, Land and Governance Branch, and youth and employment under the Youth and Job Creation Unit in the Urban Economy Branch.



CREATING KNOWLEDGE PLATFORMS OPENS UP THE POSSIBILITY FOR “ECOSYSTEMS OF INTERACTION” TO ENGAGE THE PUBLIC IN CO-CREATION AND COOPERATIVE WORK THAT SPARKS INNOVATION AND ENTREPRENEURSHIP. THEY DO SO BY PROVIDING ENABLING ENVIRONMENTS WHERE STAKEHOLDERS CAN USE PREDEFINED TOOLKITS TO SET COMMON GOALS AND TO SOLVE CLEAR URBAN PROBLEMS.



The initiative, which began in August 2012, entails centres of innovation and entrepreneurship where young people create new digital technologies to overcome urban challenges. The Labs call young people to a process that catalyzes and channels their creativity; strengthens existing initiatives in the local ecosystem of innovation and entrepreneurship; fosters synergies between such actions; and promotes global talent networks to improve cities.

Citizen participation, particularly civic engagement of youth, is the main political goal of the Labs. Its process benefits government and citizens by helping develop leadership and management skills that increase awareness, facilitate decision-making, promote tactical influence, and opens up new paths for change. The empowerment of multiple stakeholders, and their interconnection to relate and act, comes from the application of social innovation processes that enable the creation of civic-oriented technologies by communities to solve local challenges through civic engagement and collective action<sup>28</sup>.

The Lab process is coordinated with local actors, public institutions and the private sector, to be most beneficial. It is composed of three phases: creativity, innovation and entrepreneurship.

#### First Phase: Creativity

The first phase begins with a hackathon that lasts a weekend (36 hours). The participants aged 18 to 30 years have a multidisciplinary background and are challenged with a specific urban theme of their local context.

Calls for participation in hackathons include posters, banners and infographics distributed through social media and physical presence. Banners present, with a compelling visual design, the urban issue to be solved, with a tagline that attracts and orients the potential audience toward the theme to tackle with an app prototype. Infographics give more clues in a couple of paragraphs that summarize, daily, the dynamics of the event; the roles of competitors, jury, and mentors; the desired profiles of participants; the results expected; and following steps after winning the contest.

Figure 2. City Changer Labs Promotion Material.



A format questionnaire for enrollment, at a website registration link helps detect the background and particular ideas of participants, and allows them to conduct, during two weeks, the selection of a balanced group of social innovators, software developers, marketing, design, communication and entrepreneurs. An intense interchange of e-mails, chats with registry and local communities complements the selection process in order to balance a group of talented multidisciplinary and creative individuals.

On the morning of the first day, the challenge is explained in detail, together with the context that gives relevancy to its solution. The criteria for selecting the winners are presented. These are innovation and creativity of the proposed idea, social impact of the app, and capacity of the winning team to develop a commercial product.

Thirty-six hours later participants deliver a functional prototype and hand in two products: a code and a slide presentation of their idea. A panel of judges formed by renowned leaders and thematic experts, local authorities, academia and private sector, grade their results, deliberate in private, and a final verdict is publicly announced.

### Second Phase: Innovation

The winners advance to the second phase of the process, where the app developers receive a four-month scholarship to convert the prototype of the awarded application into a version ready for public launch. They have the four months to complete this process, with the support of academic institutions and the private sector.

Agreements with city authorities and public-private partnerships are signed to enable the sustainability and viability of the app and its “back office” in order to feed public policy instruments and urban activities.

During this stage youth are also trained in marketing, advertising, and communication, among other subjects, that should be incorporated into the commercial future of the application.

### Third Phase: Entrepreneurship

The stage begins when the app is ready for the next leap: to become public and for general use. During the next four months activities include brainstorming sustainable business model alternatives; formalizing the status of the app into a start-up; and liaising with local actors to include this new start-up technology to the local social fabric.

### Results

All applications are open source, and with a Creative Commons Attribution-NonCommercial-ShareAlike license that allows creators to share their knowledge with an open, agile, but controlled copyright.

So far, there are six City Changer Labs: three in Mexico, one each in Central and South America, and a joint partnership in Miami, United States.

#### Its themes are:

- “Youth and Governance” (2012), in Mexico City, with the support of Telmex, the largest Mexican telecommunications carrier.
- “Youth and Public Space” (2013), in Monterrey, Mexico, promoted by the Laboratorio de Convivencia and IMPLAN, Instituto Municipal de Planeación y Convivencia.
- “Youth and Financial Inclusion” (2013), in San Salvador, El Salvador, with the participation of UN-Habitat and AECID (Agencia Española de Cooperación Internacional para el Desarrollo.)
- “Youth and Hard-Cities/Soft-Cities” (2013), a virtual CCL at TAGDF, a Televisa event in Mexico City.



- “Youth and Urban Resilience” (2014), in Medellin, Colombia, as part of the 7th World Urban Forum, and the first international hackathon.
- “Social Good: Using Technology to Solve Problems in Emerging Markets” (2014), in Miami, USA, with eMerge Americas 2014

As a result, there have been near 600 participants, 65 new apps prototypes and 6 winners: “City Changes”, an aggregator of citizen initiatives; “Kualy”, good stories to counteract a social imaginary of violence; “KKO”, a bankless mobile finance alternative; “Air Predictor”, a personal and personalized air quality monitor; “WeMake” a network-making resource for social resilience; and “DLD” a community engagement tool for GitHub<sup>29</sup> software developers interested in social good.

Our experience has met with extraordinary interest from local and international youth, as well as support from local public-private partnerships, authorities, private enterprise, and academic institutions.

The City Changer Labs facilitate the participation of young people to become active citizens in the democratic transformation of their cities’ management, and improvement of the local digital and knowledge economy.

Among the lessons learned is the importance of creating controlled ecosystems of interaction for people to participate. Equally important to understand is that the definition of urban issues can be bettered by building upon existing participatory processes already binding communities of interest, such as MyWorld and the United Nation Global Survey for a Better World where citizens vote on issues relevant to their

daily lives. There has been strong support in all Labs from different interest groups; the coincidences with their causes and goals definitely promote synergy. The mixture of different backgrounds of participants in multidisciplinary teams contributes strongly to richer proposals and opens up new opportunities for cooperation and even friendship.

It has not been easy to create platforms of knowledge and data as foundations on which to build these enabling environments for interaction. Neither has it been a simple matter to keep the enthusiastic support of resources for phase two: scholarships, nor to wait for much longer periods of development of commercial products, such as up to two years for the first app, nor to appease fearful local politicians of their imaginary threats from social networks for unresolved citizens initiatives.

The measurable benefits for governments and citizens, until now, have been the response of interest, both in the number of participants as in the sum of stakeholders engaged in the process. It is too early in the programme to deliver meaningful statistics for the selected applications, as most are still under development. However, it is essential to mention what has happened around each event, and how these events have become important entry points for citizen engagement.

Telmex transformed the results of the hackathon into an app called “+xmiciudad”, to be launched on 21 August 2014 in 31 Mexican State capitals; and to continue, in a second phase, along 98 additional Mexican cities where the UN-Habitat City Prosperity Index is about to be computed.

Figure 2. City Changer Labs App Examples



**Table 1** City Changer Institutions Involved

THEME	LOCAL COUNTERPART	LOCAL SUPPORT	NUMBER OF INSTITUTIONS	NUMBER OF PARTICIPANTS	NUMBER OF APPS & PROJECTS	ADDITIONAL RESULTS
Youth and Governance	CTIN, Centro de Tecnología e Innovación de América Móvil, Telcel y Telmex	Telmex	1	100	13	"xmciudad" an API for citizen participation has been developed by Telmex and is ready to be launched first in 31 state capitals of Mexico, and 92 other cities in the country and Latin America with America Movil.
Youth and Public Space	IMPLANC, Instituto Municipal de Planeación y Convivencia. LABC, Laboratorio de Convivencia	Local Government: Municipality of Monterrey; Academia: ITESM, Instituto Tecnológico de Estudios Superiores de Monterrey, Facultad de Arquitectura de la UANL, Universidad Autónoma de Nuevo León. Private Sector: Axtel, Arca Continental CocaVCola, CAINTRA, Cámara Nacional de la Industria de la Transformación, CANACO, Cámara Nacional de Comercio, Ecotono Urbano; Ecosystem of Innovation and Entrepreneurship: Reto Naranya, Hackerspace, Consejo de Software de Monterrey, ACM Monterrey, CoVWorking, Viral, OpenData MTY, Yo Propongo, Ashoka y Vertebrata.	20	70	9	WebValleys, actual transformation of public spaces, with urban design and free WiFi, in Barrio Histórico, Historic District Downtown Monterrey.
Youth and Financial Inclusion	ONU-Habitat El Salvador & AECID, Agencia Española de Cooperación Internacional para el Desarrollo	International: AECID, Agencia Española de Cooperación Internacional para el Desarrollo, Embajada de España en El Salvador, Centro Cultural de España. Local Government: Ministerio de Educación, Ministerio de Economía, Instituto de la Juventud de El Salvador. Academy: Universidad Tecnológica, Universidad Francisco Gavidia. Private Sector: Telefónica El Salvador, TIGO, SVNet, CASATIC, Cámara Salvadoreña de Industrias de Tecnologías de Información y Comunicaciones. Social Sector: CONEXIÓN, Asociación Conexión al Desarrollo de El Salvador, Yawal, INSERT.	16	70	6	Winning App remained as prototype as scholarships were not delivered by sponsors.
Youth and Hard & Soft Cities	Televisa & Codeando México	Local Authorities: none. Academy: Universidad Politécnica del Valle de México. Private Sector: Televisa Social Sector: Codeando México.	3	90	3	Product developed by students at the Universidad Politécnica del Valle de México. Environmental Monitoring Agency in Federal District has manifested interest to apply it as counterpart to its official air quality monitoring network.
Youth and Urban Resilience	Museo Casa de la Memoria	International: UN-Habitat City Resilience Profiling Program, UN-Habitat Youth Fund, Barcelona Supercomputing Center. Local Government: Alcaldía de Medellín, Ruta N, UNE, Dirección de Equidad y Políticas Demográficas y FOPAE, Fondo de Prevención de Emergencia de la Alcaldía de Bogotá. Academy: Universidad EAFIT, Centro de Estudios Urbanos y Ambientales, Universidad de Antioquia, Instituto de Antioquia, Cátedra UNESCO Sostenibilidad. Private Sector: anonymous. Social Sector: MITV Harvard Club de Colombia, Casa Tres Patios, Un/loquer, PlatoHedro, Hackerspace, Laboratorio de Convivencia de Monterrey.	20	70	7	Prototype is under development.
Tech for Good	eMerge Americas	Local Authorities: MiamiDade County. Academy: University of Miami. Private Sector: Medina Capital, Microsoft. Social Sector: SecondMuse.	4	200	33	Prototype is under development, and patent registration underway.
Block by Block at Aldea Digital 2014	Telmex	International: UNVHabitat. Local Authorities: GDF, Gobierno del Distrito Federal, Labpc, Laboratorio para la Ciudad. Academy: UNAM, Universidad Nacional Autónoma de México. Private Sector: Telmex. Social Sector: Minecraft Community of Gamers.	5	7,429	431	Children projects are ready to be studied as a research thesis for Urban Planning Degree by volunteers that helped during Aldea Digital. City Budget to be allocated for construction of 2015 edition.
<b>Totals</b>			<b>69</b>	<b>8,029</b>	<b>502</b>	

The original hackathon became an entry point for a public-private-people partnership which, although it took two years to complete, led to the creation of an online training programme for capacity-building on urban development. This training programme will concentrate the accumulated knowledge of UN-Habitat with the digital resources of the company to support public officials, civil society and academia.

The urban challenge notion of the City Changer Labs and the UN-Habitat Block-by-Block initiative were applied to a children's competition within Aldea Digital 2014.

Organized by Telmex, it is the world largest digital inclusion event at the Zocalo. In 2014, it broke three Guinness World Records with 258,986 visitors in two weeks, and 177,517 trainees in 44 open workshops where more than 35,000 participants, of all ages and socioeconomic backgrounds, used a computer and e-mail for their first time<sup>30</sup>.

The UN-Habitat Block-by-Block initiative was applied to teach children, through playing with Minecraft, how to build public space. With Telmex and Laboratorio para la Ciudad, the Government of the Federal District, we proposed Reto Tlaxcoaque: "Juega y Cambia tu Ciudad" (in Spanish: "Tlaxcoaque Challenge: Play and Change your City").

Plaza Tlaxcoaque at the Historic Centre of Mexico City was digitally modelled in Minecraft and children were asked to propose designs to improve its accessibility, conviviality, security and playfulness by using the Minecraft palette, with the opportunity to win four xBox One.

The response was unexpectedly overwhelming: 7,429 children came to play, 1,438 proposed ideas and 431 projects were completed. This experience shows how strong children's interest can be when a concrete challenge is presented within a controlled ecosystem of interaction, with predefined tools or games available to construct solutions.

There were a smaller number of contestants in the Labs because participation was restricted to an older, multidiscipline, and creative crowd: 600 competitors and 65 app prototypes. A major impact has been in the response of 69 institutions - among them international agencies, local government, the private sector, academia and non-governmental organizations - willing to support the Labs. (See table 1)

## Solutions and Recommendations

City Changer Labs can help democratize management of a city and lead it to greater efficiency; create a global urban innovation ecosystem; promote the talent of young people to develop socially relevant urban

Figure 4. Block-by-Block Competition at Aldea Digital 2014





Figure 5. Block-by-Block Competition at Aldea Digital, Reto Tlaxcoaque



technologies; foster entrepreneurial skills and strengthen economic sustainability of their initiatives; facilitate the insertion of new high-tech companies into their social fabric; and promote the application of new tools in the planning, construction and operation of cities.

Their impacts can be in:

**1. Technology:** Create Urban Innovation Centres for active citizenship. These creative spaces shall combine living labs, places for co-working, education and training; arenas for cooperation and competition; posts for discovery and reward of young talent; and sites where new citizen leaders can emerge.

**2. Entrepreneurship:** Develop and capitalize on new technologies emerging from these centres, with “entrepreneurial environments” that foster multidisciplinary teams, incubation, acceleration and financing of new high-tech companies.

**3. Collaboration:** Promote public-private partnerships to address technological opportunities with new synergies of active education; information and dissemination channels; confluence of international and national networks of cities, technology and social action; committees of international experts; forum for international standards of digital cities.

**4. Market:** Promote urban technology development agencies for new markets in urban management policies and services; platforms for the development of applications; business partnership opportunities; and local managers of City Protocol, the international protocol on functional criteria and best practices for smart cities.

Overall, the City Changer Labs facilitate the participation of young people to become active citizens in the democratic transformation of their cities’ urban management and improvement of the local digital and knowledge economy. The developed tools intend to be fully integrated into their urban environment, to provide better solutions to the current urban problems and issues.

## Future Research or Operational Directions

The rationale for future development of City Changer Labs and digital civics lie in the actual context cities. Cities, throughout the mobile world, now have good quality communication infrastructure waiting for innovative ways to make a positive impact on citizens. There is an ever-growing resource of leadership and locally available capacity for technology-based programming. There are real opportunities to turn collective innovation into practical actions. Each day increases the potential for cross-departmental collaboration in city management. Public-private partnerships and new methods or citizen engagement can make civic-oriented technology flourish. With these new types of partnerships we are at a turning point to create more resilient cities by focusing on equity, inclusivity and the needs of the urban population<sup>31</sup>.

For the future we see a collective research of urban issues, citizen engagement and collective action through the development and construction of replicas of platforms, ecosystems; and interfaces of governance in different fields of urban knowledge, working like building blocks, or Lego pieces, for cross-cutting standardization of models, categories and measurements, which can integrate digital civics into the movement of open culture.

## Conclusion

City Changer Labs can contribute to UN-Habitat’s mission to promote active citizenship through urban centres of technological innovation and youth-led development.

The social relevance of digital civics consists in making knowledge open and collaborative, interactions possible in diverse tool-making environments, with governance always in control of public rule-making opportunities.

## References

- Bannon, L. (2014). What is Activity Theory?, Retrieved 19 August 2014. Available from <http://carbon.ucdenver.edu/~mryder/itc/activity.html>
- Ben Attar, D., and Campbell, T. (2012). ICT, Urban Governance and Youth. Report 4: Global Youth-Led Development Report Series. UN-Habitat.
- Block-by-Block (2014). Retrieved 19 August 2014. Available from <http://blockbyblock.org/post/84516320603/aldea-digital-block-by-block-winners-announced>
- Castells, M. (2008). Space of Flows, Space of Places: Materials for a Theory of Urbanism in the Information Age. In Tigran Haas (Ed.) *New Urbanism and Beyond: Designing Cities for the Future* (pp. 314-321). New York, NY: Rizzoli.
- Euromonitor International (2012). Special Report: The World's Youngest Population. Retrieved 10 July 2014. Available from <http://blog.euromonitor.com/2012/02/special-report-the-worlds-youngest-populations-.html>
- GitHub (2014). Build software better, together. Powerful collaboration, code review, and code management for open source and private projects. Retrieved 10 July 2014. Available from <https://github.com>
- Global Green Growth Institute (2014). Global Green Growth Knowledge Platform. Retrieved 19 August 2014. Available from <http://www.greengrowthknowledge.org/about-us>
- Govela, A., and Massarrat N. (2014). Digital Civics Initiative, Improving Cities through Innovation, Collaboration and Technology. City of Ideas 2014, Gifted Citizen Proposal. Puebla, Mexico.
- Guinness World Records (2014). Telmex logra tres records en Aldea Digital. Retrieved 26 July 2014. Available from <http://www.guinnessworldrecords.es/news/2014/4/telmex-logra-tres-records-en-aldea-digital-2014-57239/>
- Internet World Stats (2014). Usage and Population Statistics. Retrieved 10 July 2014. Available from <http://www.Internetworldstats.com/stats.htm>
- Itto, J. (2014). Want to Innovate? Become a 'Now-ist'. TED 2014. Retrieved 10 July 2014. Available from [http://www.ted.com/talks/joi\\_ito\\_want\\_to\\_innovate\\_become\\_a\\_now\\_ist?utm\\_source=t.co&awesm=on.ted.com\\_e0lBd&share=1a85706e51&utm\\_content=roadrunner-rshorturl&utm\\_campaign=&utm\\_medium=on.ted.com-none](http://www.ted.com/talks/joi_ito_want_to_innovate_become_a_now_ist?utm_source=t.co&awesm=on.ted.com_e0lBd&share=1a85706e51&utm_content=roadrunner-rshorturl&utm_campaign=&utm_medium=on.ted.com-none)
- ITU (2013). The World in 2013. ITC Facts and Figures. Retrieved 19 August 2014. Available from <http://www.itu.int/en/ITU-D/Statistics/Documents/facts/ICTFactsFigures2013-e.pdf>
- Kaptelinin, & A., Nardi, B.A. (2006). *Acting with Technology: Activity Theory and Interaction Design*, Cambridge, Massachusetts: The MIT Press.
- Leckart, S. (2012). The Hackathon Is On: Pitching and Programming the Next Killer App. *Wired Magazine*. Retrieved 9 July 2014. Available from [http://www.wired.com/2012/02/ff\\_hackathons/all/1](http://www.wired.com/2012/02/ff_hackathons/all/1)
- Levy, S. (2010). *Hackers.*, Sebastopol, California. O'Reilly Media.
- Manifesto for Agile Software Development (2014). Retrieved 10 July 2014. Available from <http://agilemanifesto.org>
- Seventh World Urban Forum Medellín Declaration. Equity as a foundation of sustainable urban development. Retrieved 1st. February 2015. Available from <http://unhabitat.org/7th-world-urban-forum-medellin-declaration/>
- Neirotti, P., and others (2014). Current trends in Smart City initiatives: Some stylised facts. *Cities*, 38, 25-36.
- United Nations (2010). World Programme of Action for Youth. Retrieved 10 July 2014. Available from <http://www.un.org/esa/socdev/unyin/documents/wpay2010.pdf>
- United Nations (2010). Youth Participation in Development. Summary Guidelines for Development Partners. Retrieved 10 July 2014. Available from <http://social.un.org/youthyear/docs/policy%20guide.pdf>
- United Nations (2011). World Urbanization Prospects, The 2011 Revision. Retrieved 10 July 2014. Available from [http://esa.un.org/wpp/ppt/CSIS/WUP\\_2011\\_CSIS\\_4.pdf](http://esa.un.org/wpp/ppt/CSIS/WUP_2011_CSIS_4.pdf)
- UN-Habitat (2011). I'm a City Changer Campaign. Retrieved 10 July 2014 from <http://imacitychanger.unhabitat.org>
- United Nations (2012). World Population Prospects: The 2012 Revision. Retrieved 10 July 2014. Available from <http://esa.un.org/unpd/wpp/Excel-Data/population.htm>
- United Nations (2014). Sustainable Development Knowledge Platform. Retrieved 19 August 2014. Available from <http://sustainabledevelopment.un.org>
- World Bank Live (2011). Realizing the Demographic Dividend: Challenges and Opportunities for Ministers of Finance and Development. Retrieved 10 July 2014. Available from <http://live.worldbank.org/realizing-demographic-dividend-challenges-and-opportunities-ministers-finance-and-development>

## Endnotes

1. Kaptelinin, & A., Nardi, B.A. (2006). *Acting with Technology: Activity Theory and Interaction Design*, Cambridge, Massachusetts: The MIT Press.
2. United Nations (2011). World Urbanization Prospects, The 2011 Revision, Retrieved July 10, 2014 from [http://esa.un.org/unup/pdf/WUP2011\\_Highlights.pdf](http://esa.un.org/unup/pdf/WUP2011_Highlights.pdf)
3. Castells, M. (2008). Space of Flows, Space of Places: Materials for a Theory of Urbanism in the Information Age. In Tigran Haas (Ed.) *New Urbanism and Beyond: Designing Cities for the Future* (pp. 314-321). New York, NY: Rizzoli.
4. Neirotti, P., De Marco, A., Cagliano, A. C., Mangano, G., & Scorrano, F. (2014). Current trends in Smart City initiatives: Some stylised facts. *Cities*, 38, 25-36.
5. Seventh World Urban Forum Medellín Declaration. Equity as a foundation of sustainable urban development. Retrieved 1st. February 2015. Available from <http://unhabitat.org/7th-world-urban-forum-medellin-declaration/>
6. Govela, A. & Massarrat N. (2014). Digital Civics Initiative, Improving Cities through Innovation, Collaboration and Technology. Gifted Citizen Proposal for City of Ideas 2014, Puebla, Mexico.
7. United Nations (2012). World Population Prospects: The 2012 Revision. Retrieved July 10, 2014 from <http://esa.un.org/unpd/wpp/Excel-Data/population.htm>
8. United Nations (2011). op. cit
9. ITU (2013). The World in 2013. ITC Facts and Figures. Retrieved August 19, 2014 from <http://www.itu.int/en/ITU-D/Statistics/Documents/facts/ICTFactsFigures2013-e.pdf>
10. Internet World Stats (2014). Usage and Population Statistics. Retrieved July 10, 2014 from <http://www.internetworldstats.com/stats.htm>
11. United Nations (2010). World Programme of Action for Youth. Retrieved July 10, 2014 from <http://www.un.org/esa/socdev/unyin/documents/wpay2010.pdf>
12. United Nations (2010). Youth Participation in Development. Summary Guidelines for Development Partners. Retrieved July 10, 2014 from <http://social.un.org/youthyear/docs/policy%20guide.pdf>

13. Euromonitor International (2012). Special Report: The World's Youngest Population, Retrieved July 10, 2014 from, <http://blog.euromonitor.com/2012/02/special-report-the-worlds-youngest-populations-.html>
14. World Bank Live (2011). Realizing the Demographic Dividend: Challenges and Opportunities for Ministers of Finance and Development, Retrieved July 10, 2014 from <http://live.worldbank.org/realizing-demographic-dividend-challenges-and-opportunities-ministers-finance-and-development>
15. Ben Attar, D., & Campbell, T. (2012). ICT, Urban Governance and Youth. Nairobi, Kenya. UN-Habitat Report 4: Global Youth-Led Development Report Series.
16. Levy, S. (2010). Hackers, Sebastopol, California. O'Reilly Media.
17. Leckart, S. (2012). The Hackathon Is On: Pitching and Programming the Next Killer App. Wired Magazine. 02.17.12. Retrieved July 9, 2014 from [http://www.wired.com/2012/02/ff\\_hackathons/all/1](http://www.wired.com/2012/02/ff_hackathons/all/1)
18. Manifesto for Agile Software Development (2014). Retrieved July 10, 2014 from <http://agilemanifesto.org>
19. Ito, J. (2014). Want to innovate? become an 'now-ist'. TED2014, Retrieved July 10, 2014 from [http://www.ted.com/talks/joi\\_ito\\_want\\_to\\_innovate\\_become\\_a\\_now\\_ist?utm\\_source=tc&awesm=on.ted.com\\_e01Bd&share=1a85706e51&utm\\_content=roadrunner-rshorturl&utm\\_campaign=&utm\\_medium=on.ted.com-none](http://www.ted.com/talks/joi_ito_want_to_innovate_become_a_now_ist?utm_source=tc&awesm=on.ted.com_e01Bd&share=1a85706e51&utm_content=roadrunner-rshorturl&utm_campaign=&utm_medium=on.ted.com-none)
20. Castells, M. (2008). op. cit.
21. Kaptelinin, A., and Nardi, B.A. (2006). op. cit.
22. Bannon, L. (2014). What is Activity Theory?, Retrieved August 19, 2014 from <http://carbon.ucdenver.edu/~mryder/itc/activity.html>
23. United Nations (2014). Sustainable Development Knowledge Platform, Retrieved August 19, 2014 from <http://sustainabledevelopment.un.org>
24. Global Green Growth Institute (2014). Global Green Growth Knowledge Platform, Retrieved August 19, 2014, from <http://www.greengrowthknowledge.org/about-us>
25. See <http://blockbyblock.org/post/84516320603/aldea-digital-block-by-block-winners-announced>
26. Goveia, A. & Massarrat N. (2014). op. cit.
27. UN-Habitat (2011). I'm a City Changer Campaign, Retrieved July 10, 2014 from <http://imacitychanger.unhabitat.org>
28. Goveia, A. & Massarrat N. (2014). op. cit.
29. GitHub (2014). Build software better, together. Powerful collaboration, code review, and code management for open source and private projects. Retrieved July 10, 2014 from <https://github.com>
30. Guinness World Records (2014). Telmex logra tres records en Aldea Digital. Retrieved July 26 from <http://www.guinnessworldrecords.es/news/2014/4/telmex-logra-tres-records-en-aldea-digital-2014-57239/>
31. Goveia, A. & Massarrat N. (2014). op. cit.







# What's after Land Tenure?

## From Squatter Settlements to Participative Local Governments

### ○ Claudia Sakay

Ph.D. in Design, Architectural Design Program, The University of Tsukuba, Japan

### ○ Paola Sanoni

Ph.D. in Political Science, Graduate School of International Public Policy, The University of Tsukuba, Japan

### ○ Toshihiro Hanazato

DEng, Professor, School of Arts and Design, The University of Tsukuba, Japan

### Abstract ○

Land tenure security enforces community participation in local governments. Additionally, it promotes community-based organizations (CBO) as social inclusion strategy in the process of urban inclusion due to their influence on local governments for decision-making. In 1983, in the squatter settlement of Manchay, the need for survival generated a reason for establishing a CBO in the search for land tenure rights. In 2013, these communities were facing the challenges of inclusion to the local government system.

The role of information and communication technologies (ICTs) is to facilitate communication between citizens and governmental institutions for compliance of their rights and be included in the process of governance. This study analyses the role of the CBO in the squatter settlement of Manchay in Lima during the process of achievement of legitimate land rights towards their inclusion on their local government, and how ICTs contribute to this inclusion process. Empiric data collection registers 73 in-depth structured interviews taken between 2010 and 2013.

### Keywords:

Squatter settlements, e-governance, ICT, CBO, land tenure, participative government

## Introduction

Information and Communication Technologies provide a set of tools to support the processes of communication between the communities and individuals. Moreover, it provides the tools to establish a liaison with their representatives and authorities creating ties of joint effort and trust, promoting collaborative processes of e-governance in a platform where citizens have the right to express their needs, opinions and propose solutions to solve the significant problems in their locality. In Peru, the implementation of e-governance informatic platforms and ICT tools are used to articulate, moderate and summarize the citizen's contributions and feedback, which facilitates open access to information for all citizens. The usage of ICT contributes toward the promotion of national programmes, particularly in squatter settlements where low-income populations can access information and establish communication with their representatives in local government online 24 hours a day from private booths and telecentres.

Squatter settlements in Peru have a long history due to a process of informal and rapid urbanization, which reached its record in the 1960's (Riofrio, 2003). In the last 20 years these informal neighbourhoods - mainly characterized by inadequate access to water and sanitation, poor quality of housing and insecure residential status - continue to demand the right to own land, as the need for housing and infrastructure has never ceased (UN-Habitat, 2007). Consequently, the social, economic, political, spatial and environmental conditions open debate about the association between the illegal conditions of squatter settlements with the process of legalization of the properties for the urban poor.

Observations and assertions during the land formalization process, has led to communities organizing themselves to demand that their local governments install basics such as electricity, water, sewage and access to communication means. These demands show that the concept of safety for squatter populations is related to improved conditions of housing and neighbourhoods (Durand-Lasserre, 2006). In this scenario, community participation becomes the mechanism of communication of squatter settlements and their authorities accomplishing a role in sustainable development becoming the new paradigm on how the poor increasingly take the initiative in ensuring their needs, rights and tenure security.

In this context, community-based organizations are considered representatives of the citizenry, able to be involved in the design, implementation and management of community improvement projects. Therefore, community-based organizations are a key element of social order in squatter settlements as they mark the patterns of communication between citizens and their local governments, promoting participation and establishing mechanisms for e-governance. This phenomenon explains the importance of these organizations for the spreading of ICT on the implementation of e-government processes. Using ICT as open platforms for exchanging needs and solutions in the form of opinion, local authorities can receive information and ideas about a settlement's issues, often hitherto jeopardized by fear of eviction or retaliation.

E-governance in squatter settlements can support and simplify governance for all parties, backing the delivery of government products and services, promoting exchange of information, streamlining communication, transactions and system integration using ICT. Thus said, ICT become the pieces of the puzzle with the capacity to break all barriers of communication between citizens and government. Still, access remains uncertain in a population with limited resources. On the other hand, squatter communities are demanding transparency in the management of local government resources management, autonomy after decentralization, and greater independence to express their demands, prerogatives and priorities. In response, governments had shown interest in the implementation of platforms for e-governance to attend to specific needs of their communities by opening a communication channel for all citizens.



THE USAGE OF ICT CONTRIBUTES TOWARD THE PROMOTION OF NATIONAL PROGRAMMES, PARTICULARLY IN SQUATTER SETTLEMENTS WHERE LOW-INCOME POPULATIONS CAN ACCESS INFORMATION AND ESTABLISH COMMUNICATION WITH THEIR REPRESENTATIVES IN LOCAL GOVERNMENT ONLINE 24 HOURS A DAY FROM PRIVATE BOOTHS AND TELECENTRES.



This chapter aims to identify the use and functionality of ICT and the incipient processes of e-government implemented in the squatter settlement of Manchay in Lima, Peru, during the process of achievement of legitimate land rights towards their inclusion on their local government. It is the focus of the chapter to explain how e-governance and the use of ICT can improve communication between illegal occupants of the land and local authorities. Additionally, the chapter seeks to explain what happens when inhabitants become owners of land with rights to participate in local government policymaking, and how they conceptualize the so-called process of social inclusion. Literature review, observation, interviews and empiric data collection has been used to gather information. Data processing facilitated cultural understanding of poor people's communication means and relations with government institutions. Between 2010 and 2013, there have been 73 in-depth structured interviews in the first plot of the squatter settlement of Manchay, in Lima's Pachacamac District.

## Background

In Peru, the process of irreversible migration from the Andes Mountains and the jungle into the peripheral areas of Lima on the coast started in the 1950's. This movement gained in intensity in the 1980's and 1990's due to the collateral effects of political conflicts and terrorism in rural

areas. Squatter settlements grew on private lands or governmental resettlement projects on state-owned peripheral ground, resulting in informal and formal land tenure arrangements (Calderon, 2004). In response to the continuing land invasion, the correspondent authorities of the central government had eventually legalized most informal settlements applying a combination of mechanisms of land tenure and registration, and implementation of infrastructure projects. Moreover, processes of participative policymaking established by law promote the inclusion of inhabitants' opinions and proposals into the local governance process, giving space for the use of ICT as tools for collecting ideas, opinions and responses, thus ensuring dialogue between citizens and authorities.

Land tenure in squatter settlements took on a different hue before 2000 when informatics was introduced to simplify central government administration. From 1982 to 1986, the metropolitan municipality of Lima extended 134,000 land titles in the attempt to formalize squatter settlements. However, more than 100,000 of these titles were lots without basic services. Land regularization became incoherent and fragmented but saved the State money (Calderon, 2004). While authors like De Soto (2000) are convinced that the effect of land titles is usually significant, others think that the effects are only moderate (De Souza, 2011; Gilbert, 2002; Payne, 2001). In 1996, formal land tenure was backed by statutory law; that is through the creation of the Commission for the Official Registration of Informal Property. The Commission's policy was supported by the World Bank and was inspired by the vision and ideas of the Peruvian economist, De Soto (2000). He said that legalization of ownership and registering titles had a positive effect on squatter populations. The commission follows chronologically with the penetration of the Internet in public administration (1996), later incorporating the massification of connectivity services and e-government, promoting the use of ICT for inclusion of public opinion on policymaking as declared on its website.

At the same time, community participation in squatter settlements in Peru was promoted by community-based organizations at the onset of a land invasion and during the whole settlement process (Riolfrio, 2003). The incentives to organize collectively come out of the need to shape formal representative leaders for negotiations with the local authorities in order to settle legal issues and to solve basic needs for squatters such as formalization of informal property, as well as the provision of potable water, sewage, electricity, health, nutrition and education.



PARTICIPATION IN DECISION-MAKING COULD ONLY BE REACH IF COMMUNICATION IS ESTABLISHED (BULTER, 2011). BESIDES, THE ADOPTION OF A TELECOMMUNICATIONS LAW OBLIGATES PRIVATE OPERATORS TO PROVIDE SERVICES COUNTRYWIDE.



## ICT AND E-GOVERNANCE IN SQUATTER SETTLEMENTS

Information and communication technologies have been defined widely in literature, generally encompassing all sorts of data processing and transmission instruments that provide communication to enhance understanding between citizens. In this chapter, ICTs are defined in the context of current use by governments as a transversal tool to promote communication and coordination between institutions, and provide transparency in public management. The technologies are also tools with which to connect public servants and citizens to understand state functions and capacities, and citizens' needs for improving formulation, implementation and evaluation of processes and policies.

The utilization of ICTs supports rapid urban growth through communications flows and interaction between individuals and organizations, helping to connect and integrate people to communities associated by interests. Once infrastructure has been provided, and considering training costs, still the low cost of maintenance of these technologies, facilitates access for depressed economies, making it more accessible than landline telephone or even mobile services. Thus, in poor societies such as squatter settlements, ICTs have shown evidence of being useful in promoting social and economic dynamism (Wheeler et. al, 2000).

The use of ICTs to support e-governance is a powerful incentive for the participation of the urban poor in decision-making because it improves coordination for delivery of basic services, enhances local development opportunities, and promotes political accountability due to the need to obtain response (UNDP, 2003). However, in developing countries, the main problem of e-governance is related on the availability of ICT infrastructure. Despite the huge potential of ICTs to assist communities increase their overall well-being through community development, the lack of external funding for equipment can be a barrier to success as provision in itself is no guarantee of successful adoption in a community (Harris, 2001). The ICT use in the public sector is very little. Therefore, the first stage for an e-government has been the organization of its internal operations, services and then the change toward Internet-based systems. (Bhatnagar & Bjorn-Andersen, 1990). Moreover, e-government in squatter settlements must accommodate certain unique conditions, needs and obstacles (Heeks, 2001). For instance, they have poor infrastructure, weak educational systems, and unequal access to technology. Furthermore, there are community-based disadvantages resulting from uneven societal adoption of ICTs (Castells, 2000). Provision of infrastructure for ICT access (broadband), either high or low capacity through government and private sector efforts, by itself is insufficient to deal with these issues (Marshall et. al, 2003).

The presence of ICTs in squatter areas is becoming complex between the space of flows and the space of places which binds new landscapes, political and cultural interactions (Castells, 1999; Skeates, 1997). In other words, the implementation of ICTs attempts to invigorate political relations by allowing direct community participation in government, avoiding mediations, optimizing the representative process, and expanding participative democracy and governance. Therefore, squatter

communities can use the access to ICTs to modifying their living conditions by actions such as organizing projects related to land tenure regularization, infrastructure improvement and housing development. This is using ICTs to make policy changes by communicating with authorities and representatives, which otherwise would become a bureaucratic undertaking for communities and local governments.

## E-Government in the Context of Peru

Peru lies between Ecuador, Colombia, Brazil, Bolivia, and Chile. The country has an exclusive economic zone of 200 nautical miles over the Pacific Ocean with 3,080 km of coastline on its west side (INEI, 2013). Peru's capital and business hub is Lima. Once a highly centralized State, the government of Peru has been developing policies and actions for decentralization since the 1990s. Today, the country is a multiparty democracy. Regional and local governments are elected every four years in general elections. State power rests with the executive, legislature and judiciary. The ministries of the State are in charge of the executive power, which controls most of the government's budget. Its portfolio is organized by national interest including the Ministry of Dwelling Construction and Sanitation with its Commission for the Official Registration of Informal Property of 1996 (COFOPRI). The Commission is in charge of land tenure and execution of title deeds. The Ministry of Transport and Communications and its technical specialized organ, the National Office of Electronic Government, is in charge of ICT for promoting e-government and social inclusion. ICT has been used to modernize the processes of governance and offer a platform for the interaction of citizens and their representatives to promote participative decision-making, and improve their access to governmental services at local levels.

National Office of Electronic Government regulates and implements national e-government policy. The office also supervises ICT activity of the State's departments, information security, and development of ICT. Additionally, it provides advice on ICT to public entities. This office is in charge of the administration of several of the State's websites, including that of the central government, which is constituted as the interactive system of information for citizens through the Internet. Other websites are for the Services to Citizens and Enterprises, and the Commission for Development of the Society of Information (CODECI). The National Office of Electronic Government (ONGEI) is also in charge of the e-government strategy, according to the National Plan for E-Government 2013-2017 which establishes the role of ICT for promoting social inclusion (ONGEI, 2014).

The Commission for Development of the Society of Information is a multisectoral body created in 2003. Its main objective has been the elaboration of a development plan for the Society of Information in Peru to align the interest of the government sectors (economy, education, health, transport, communication, welfare, dwellings, etc). The document produced has been named the Peruvian Digital Agenda and, since its creation, has been used for monitoring and assessing the Plan of Development (CODESI, 2014). The Commission for Development of the Society of Information is now an active part of National Office of Electronic Government, integrated by members from the government, enterprises and citizen representatives. The Commission's role is to

create space for concentrating opinion. It will also form strategic partnerships with private enterprises, telephony operators, institutions of international aid, and community representatives with whom to bridge the digital divide.

Local governments are using ICT through municipal platforms to interact with governmental institutions. In 2002, after promulgation of the Law of Transparency and Access to Public Information (supreme decree no. 072-2003-PCM), the central government established the mandatory application of ICT for public institutions to communicate with the citizens over the official website that the government had provided for that purpose. Thus, public institutions must publish and maintain updated information on budgets, performance, indicators, public services and projects of public investment.

Participation in decision-making could only be reached if communication is established (Bulter, 2011). Besides, the adoption of a telecommunications law obligates private operators to provide services countrywide. Thus, 98 per cent of squatter settlements in Lima were connected to the electricity grid by 2000 (Calderon, 2004). The demand for ICT has meant that everyone may have access to telecommunications networks through broadband Internet, mobile and landline phones, satellite television, and they are able and willing to pay for these services (Sanoni, 2012).

## E-Governance Processes in the Squatter Settlement of Manchay

Established in 1983, Manchay is an example of a self-created squatter settlement in the city council area of Pachacamac, about 24 kilometers southeast of Lima. With a population of some 50,000, Manchay is an example of gradual upgrade in the quality of housing, infrastructure and other amenities in squatter settlements (Figure 1). Manchay is 11 kilometres long and 4 kilometres wide. Due to the rugged topography in which it stands, the entire settlement is divided in 28 geographical sectors. Because of these characteristics, the entire community cannot, as a whole, participate in decision-making so management of the settlement has been decided into smaller units. In this way, it is easily prey to a situation of divide, control and rule (Sheng, 1990; Sakay et. al, 2011).

Squatter settlements are represented by community members due to the massive fight against poverty that keeps them united in resisting invasion of the land by developers. Manchay's population formed community-based organizations to fight for squatter land tenure and to represent residents at the local council. The best known of these organizations is CUAQUEM, which translates to the "Unique Central Organization of Manchay". It comprises leaders who represent the settlement's 28 sectors. CUAQUEM has been accomplished for the creation of a plan for the management of Manchay, giving other community-based organizations the responsibility for safety, welfare, infrastructure and land tenure. This well-organized social and political structure provides a better understanding of their needs, facilitating the development of projects to improve the squatter settlement in a short time (Sakay & Hanzato, 2011). CUAQUEM is the main partner to the local government for promoting the use of ICT and the implementation of e-government processes in Manchay.

Figure 1. General View of Manchay Squatter Settlement. Source: C.Sakay, 2013.



Manchay belongs to the Municipality of Pachacamac, which borders Lima. Following the Law of Transparency and Access to Public Information, Pachacamac has been working on the implementation of ICT to increase local participation and redesigning administrative and management processes to modernize the delivery of services using the resources of e-governance. By creating the website in year 2000, Pachacamac aimed to provide information services, future projects, annual budgets reports and public projects. The objective was to promote the integration of their community members and offer tools for strengthening the relations between authorities and communities by providing a platform of communication to strengthen the interaction between governance and citizenship.

Table 1 shows that from 73 surveys the media most used to receive national and international information are radio (94 per cent) and television (57 per cent). Differences between the use of mobile and landline telephony (including SMS) are significant. Of those interviewed, 82 per cent prefer to use mobile telephones because they are cheap and are easily accessed. By contrast, landline telephone service charges are high and obtaining the sets requires the presentation of formal documentation proving the ownership of property, when the contract is signed with the service provider. However, as the use of computers grows, cheap access to ICT and the Internet may become the communication tool of choice in the urban environment. Presently, though, in squatter settlements like Manchay, 53 per cent of the residents cannot afford a computer. Almost half the population has no access to the Net at home but 39 per cent have access from other dwellings (table 1), showing their desire for connectivity. In surveys, inhabitants stressed the difficulties of communication, costs of infrastructure and the high access fees

to networks. Still, there is no evidence to link the use of the Net and its application in e-government processes.

**Table 1** Residents with Access to Communications.

TYPE OF COMMUNICATION ACCESS	% OF POPULATION (N=73)
Computer with internet access	39
Computer no internet access	8
No computer / no internet access	53
Land line phone	57
Mobile phone	82
Radio	94
Don't have radio	6
Television	57
Satellite television	25
Don't have television	18

(Source: by the authors).

Since 2000, the need for access to Internet connection and mobile phones in Manchay has led to the establishment of telecentres. These are public facilities that allow customers who do not have private use of a computer or the Internet to have access for educational, social media networking and economic development (Gomez & Gould, 2010). Telecentres are profitable microenterprises which provide a number of minor services such as text printing, copying documents, sending messages by facsimile, and making long-distance phone calls charged on pre-paid cards to be used on web-based global operators. Telecentres in Lima



were originated by the Peruvian Scientific Network. The Network was set up in 1991 as a private association to develop and promote use of the Internet in Peru and in other Latin American countries.

In Manchay, 6 of the 16 families who were granted land were interviewed (table 2) run home-based telecentres, which are small private booth (figure 2). Even so, there is no evidence that residents use these facilities to participate in local government. However, one noticeable aspect of Internet use in Manchay is the frequency of posts to the Net, and the information contained therein about community activities and events. In addition, it contains the number of active members of the Pachacamac69 Municipality's social media network website, which also raises the issue of access.

**Table 2** Type of Home-based Business in Manchay.

BUSINESS TYPE	NUMBER OF HOUSES (N=16)
Large grocery store	3
Small grocery store	4
Internet, phone call centers	6
Drugstore	1
Services (veterinarian, lawyer)	2

(Source: by the authors).

## E-Governance and Informal Property of Squatter Settlements in Manchay

In metropolitan Lima, poor families are inclined to obtain legal property rights to their homes and not just seize possession of them (Calderon, 2004). The traditional system of providing land titles and registration in Peru is complex, inefficient and expensive, thus unaffordable to the poor. The common failure of the government to defend or even recognize informal tenure rights in individual disputes gave rise to rent-seeking behavior in the form of invasions of untitled land (Olortegui, 2001).

In 1991, a Peruvian non-governmental organization embarked on an innovative property titling project in Lima. The organization's goal was "the rapid conversion of informal property into securely delineated land holdings by the issuing and registering of property titles" (World Bank, 1998a). Between 1992 and 1995, roughly 200,000 titles were issued at an extremely low cost, convincing the government and a growing international audience of the potential for efficiency gains from urban property formalization (World Bank, 1998b). In 1996, the Commission for the Official Registration of Informal Property (COFOPRI) was created with support of the World Bank. The Commission's role is to assure formal and sustainable rights to real State property in selected and poor settlements of larger urban areas. Registration with the Commission is not mandatory, and it can be a lengthy and costly process for squatter residents. As a result, most squatter households prefer to avoid the Commission or defer registration to a time when the land and housing subdivisions have already taken place (Sakay, 2012). Although by May 2014 (see figure 3) COFOPRI (2014) had

already distributed more than 2 million urban property titles, it was noticeable that during 1999 and 2000 the relative political stability of the country enable the implementation of the land regularization policy without much political opposition.

From 2000, COFOPRI started posting to its website the registration procedure for occupants of informal property. On the website, linked also to the official site of the Peruvian State, COFOPRI publishes cadastre information including maps, property conditions such as the number of floors, type of building, or if the property is serviced with potable water, electricity and sewage provided by municipalities. The legalization process of COFOPRI in 2014 is much more transparent due to the use of ICT, as

Figure 2. Home-based Telecentre Businesses in Manchay.



Source: C.Sakay, 2013.

Figure 3. Property Titles Granted by COFOPRI in Urban Areas.

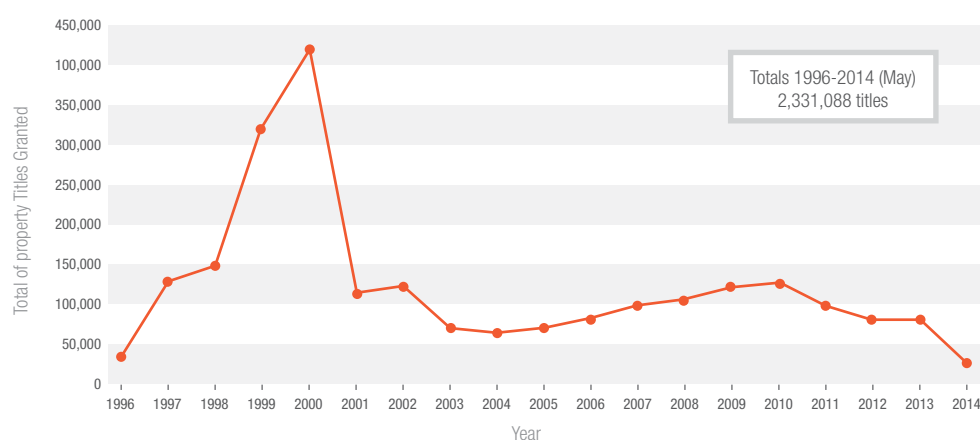

Source: the authors based on COFOPRI statistics, 2014.

e-government tools aligned with the procedures and regulation supervised by the National Office of Electronic Government (ONGEI). This programme aims to implement ICT for facilitating processes of land formalization by increasing access to public information through the COFOPRI website<sup>70</sup>. On this website, Manchay residents and every community can access online information related to land tenure formalization such as location of main offices, new calls for titles registration, requirements and also making online inquiries about the status of their properties or the profile status of the property title requested. Residents can send consultation and messages using a private e-mail account (that can be obtained free online) for receiving responses to their inquiries. However, it is still not possible to start the process of registration of their land by filling an online request. For example, CUAQUEM representatives in Manchay had access to information online and organized a meeting in December 2013 to explain the processes and other information to community members who were unable to connect to the website. Thus, communities can get together, discuss issues and agree on how to achieve their objectives. Additionally, representatives of community-based organizations can contact their local authorities to express their opinion. This is the mechanism by which these organizations can support their decisions as a group and influence local policies.

## E-Governance and Community Based Organizations in Manchay

The concept of community participation was created and defined by the United Nations in 1955 to deal with community development as a process that creates conditions of economic and social progress for the whole neighbourhood through its active participation (Kombe & Kreibich, 2000). In other words, community participation is defined as a group of people with a sense of belonging and values that represents the involvement of community members towards meeting common interests of securing tenure. This is the main reason why many authors agree on the incorporation of community participation into land regularization policy as an alternative approach adoption in land management activities (Muraya, 2006; De Soto, 2000; UNCH, 1991).

E-governance is an information and electronic model of governance that seeks to achieve processes and structures for harnessing the potentialities of ICT at various levels of government and the public sector. For their part, community-based organizations represent the spontaneous initiatives of citizen bodies to render services to communities and serve as a communication channel between authorities and the people the organizations represent. Consequently, the use of e-governance platforms conveys central government's commitment to apply these technologies as communication tools to enhance inter-institutional governmental relationships and their relations with the citizenship. The platforms also enable government to uphold human dignity and autonomy, support economic development, allow citizens to voice their opinions, and encourage efficient service delivery (Riley, 2001). Thus, community-based organizations can contribute toward the processes of e-governance by promoting the use of ICT in their communities.

In this context, community-based organizations in Peru are local voluntary non-profit groups that advocate for the welfare of the community. When the first land invasion occurred, community-based organizations provided support for the public's involvement in decision-making at the local government - especially on legal matters. Later, they took on the additional task of advocating for the provision of water, sewerage electricity and other basic public services.

There are 163 community-based organizations in Manchay. Surveys show that of 73 cases in Manchay, most people feel proud of their neighbourhood and are actively involved in the improvement of their living conditions, as the highest percentage of participation is reflected in activities related to land regularization, infrastructure development and nutrition issues (table 3).

The joint initiatives of community-based organizations in Manchay have led to the area's autonomy and safe development. Despite their limited access to education, there is a strong community yearning for modernity and easy access to modern means of communication, and for social

**Table 3** Types of CBOs in Manchay and Percentage of Participation.

TYPE OF CBO IN MANCHAY	ACTIVITIES	TOTAL NUMBER OF GROUPS	% OF PARTICIPATION (N-73)
Community Organization (CUANQUEM)	Land regularization Instalation of electricity Instalation of water	1	42%
Community Managed Kitchens (Comedores Populares)	Nutrition Provide meals at subsidised prices	95	21%
Glass of Milk (Vaso de Leche)	Nutrition Provide a glass of milk a day to children, elderly population	42	13%
Mothers Club	Socioeconomic activities support Health and wellness	15	9%
Youth Club	Education support	8	2%
Association of Vendors and Entrepreneurs	Generate income activities	1	8%
Association of Small Farmers of Manchay (APACAM)	Agriclture production	1	5%

Source: by the authors.

inclusion. For example, the National Programme for Food Assistance (PRONAA) has recently implemented a website, with the support of the local government, to attend to Manchay's community needs.

PRONAA provides food distribution to poor areas. Since 1992, it has had many channels of communication with society and community-based organizations through its "Glass of Milk" programme; serving breakfast to children, women and senior citizens in community centres. It also runs community managed kitchens. Since the website's creation, these organizations have been working to improve the website's capacity to solve community logistic and communication problems (PRONAA, 2014). PRONAA intends to solve its procurement problems and make the process more transparent by giving the number of transactions involved through online operation, publishing the bidding invitation list for products and services online, and buying directly from small-scale producers. These centres are administrated by representatives of community-based organizations, who are switching their operational methods of work from paper to the ICT tools and other forms of electronic communication.

**Table 4** Educational Background of Households interviewed.

EDUCATION DEGREE	% OF HOUSEHOLDS N=73	% OF CBO'S LEADERS N=13
No education	30	13
Elementary School	31	62
High School	25	0
Technical incomplete	2.5	15
Technical complete	6	10
University incomplete	2	0
University complete	3.5	0

Source: by the authors.

The main role of these community organizations is to create access to marginalized groups, encouraging grass-roots participation in projects and community empowerment by promoting training and supporting community activities (Sahley & Danziger, 1999). Literature shows that training for education is considered as important for sustaining local community participation (De Soto, 2000; Poerbo, 1992). Leaders of community organizations need instruction in technical and social skills, organizing communities, conducting meetings and communicating with local authorities.

Survey results show that most Manchay residents who are involved or participated in a community organization are of the first generation of migrants. Therefore, most of them only attained elementary or high school education. Still, they use ICT tools for communication and coordination activities with their community members, showing evidence of overcoming another barrier. Of the 13 leaders of community organizations interviewed, most had elementary education; only a few had technical training (table 4).

## E-Governance and Social Media Network in Manchay

Social media network websites are registering tremendous growth. Communities, online community services and several groups are getting fed with ideas by virtual communities worldwide. Access to global communication through the Internet has enabled Manchay residents to use free web-based social media networks. The Manchay community created a group profile on Facebook<sup>71</sup>, which has registered at least 22,000 visits since 2012 and remains active, providing a regular flow of posts about local community issues, events, social programmes and medical campaigns (such as vaccination and specific diseases prevention). The creation of this social media network account is used to convey information about community projects, discussion groups, events and creation of socioeconomic development through business advertisement and services. Moreover, it provides information on the

settlement that allows the creation of points of interest and facilities on Google Maps such as churches, schools, markets, police stations, parks and health centres. This helps people to organize the pursuit of common interests. These network-based applications are external to the e-government process on the platform provided by the municipality, but indicate clearly the tendencies of groups leading the community.

## Future Work and Recommendations

The main difficulty in incorporating Manchay and other squatter settlements into e-government is the situation of inherent inequality in comparison with Lima. A starting point is for local governments to begin providing land tenure security, facilitating ICT access, and promoting community participation in well-established communities. A trustful relationship between government and citizens facilitates coordination for making, implementation and compliance with policies possible. Workshops, training sessions and technical advice for communities, united by common interests, can increase the interest and confidence level in local governments. However few can make for closing the digital divide, which requires provision of infrastructure neglected by private companies.

Local governments need to strengthen their communication strategy in order to make residents and community representatives be part of the decision-making processes. Information communications technology has demonstrated its reliability as a reliable source to supply, retrieve and disseminate information, ensure transparency, and exchange experiences between community organizations, authorities and residents.

## Conclusion

This chapter explored the community of Manchay in Peru and located the community's case in the current social and political context.

Development in squatter settlements is a specific form of community participation, the success of which is determined by two key factors: first, the role of the local government and the tools they use to implement their strategies; and second, the complexity of the decision-making at the core of the community participation process. Community participation

is not easy to achieve but it is a key component as a strategy for resource mobilization toward implementation and use of e-government tools. Without the involvement of the community in planning and decision-making, improvement of projects cannot meet the needs of the community, effectively.

In the scenario of squatter settlements in Peru, there are two priority needs before implementing mechanisms of e-government and good results can be obtained. First is to start thinking about other possibilities to ease the process of land tenure formalization in order to promote private business development and economic flow to satisfy community priorities. Second, government and policymakers should consider analysing new strategies for providing formal support to squatter settlements using ICT and starting trials for online land and business registration, and encouraging the flow of information in dialogue with residents.

Joint initiatives by community organizations are powerful in supporting governance structures and making them stronger. There is evidence that official municipality websites and social media networks facilitate communication between the community organizations, residents and local governments. Therefore, project leaders and policymakers interested in community participation need to talk with representatives of community organizations and establish clear processes focused on conveying the power of local representative leaders to serve local interest.

Finally, what happens after land tenure? Once squatter settlements are legally recognized, owners are eligible to basic urban services and facilities to initiate ICT for communicating and organizing with their community leaders for solutions to government challenges. This is a long process where owners of squatter dwellings claim their right to land and provision of services, using the e-government platform. Attempts by local governments to implement ICT to improve local community participation and e-government have demonstrated that citizens are capable of using the tool to convey community initiatives. Therefore, Manchay can serve as a blueprint for replication elsewhere where there are similar development challenges.

## References

- Bhatnagar, S.C. and Bjorn-Andersen, N. (1990) *Information Technology in Developing Countries*. North, Holland, Amsterdam: Elsevier Science.
- Butler, B. S. (2011) Membership size, communication activity, and sustainability: a resource based model of online social structures. *Information, Communication and Society*, 12, 1-23
- Calderón, J. A. (2004). The formalization of property in Peru 2001-2002: the case of Lima. *Habitat International*, 28(2), 289-300.
- Castells, M. (2000). Toward a sociology of the network society. *Contemporary sociology*, 29(5), 693-699.
- Castells, M. (1999). Grassrooting the space of flows. *Urban Geography*, 20(4), 294-302.
- CODESI (2014). Comisión de Desarrollo de la Sociedad de la Información. Retrieved 8 August 2014. Available from <http://www.codesi.gob.pe/>
- COFOPRI (2014). Estadístico: titulación por año. Comisión de formalización de la propiedad informal. Retrieved 29 June 2014. Available from <http://www.cofopri.gob.pe/cifras/estadistico.aspx>
- De Soto, H. (2000). *The Mystery of Capital: Why Capitalism Triumphs in the West and Fails Everywhere Else*. New York: Basic Books.
- De Souza, F.A.M. (2011). Perceived security of land tenure in Recife. *Habitat International*, 25(2), 175-190.
- Durand-Lasserve, A. (2006). Informal settlements and the millennium development goals: global policy debates on property ownership and security of tenure. *Global Urban Development*, 2(1), 1-15.
- Gilbert, A. (2002). On the mystery of capital and the myths of Hernando de Soto: what difference does legal title make? *International Development Planning Review*, 24 (1), 1-19.
- Gomez, R., and Gould, E. (2010). The cool factor of public access to ICT: users' perceptions of trust in libraries, telecentres and cybercafés in developing countries. *Information Technology & People*, 23(3), 247-264.
- Harris, R. (2001). Research partnerships to support rural communities in Malaysia with information and communication technologies. In J. Lazar (Ed.), *Managing IT/Community Partnerships in the 21st Century* (pp. 222-247). Hershey, PA: Idea Group Publishing.
- Heeks, R. (2001). Understanding e-Governance for development. In *i-Government Working Paper Series* (Ed.), Institute for Development Policy and Management (paper No. 11) Manchester, U.K: University of Manchester.
- INEI (2013) *Compendio estadístico del Perú 2013*. Instituto Nacional de Estadística e Informática, 1, 21-29. Retrieved 3 August 2014. Available from [http://www.inei.gob.pe/media/MenuRecursivo/publicaciones\\_digitales](http://www.inei.gob.pe/media/MenuRecursivo/publicaciones_digitales)
- Kombe, W. J., & Kreibich, V. (2000). Reconciling informal and formal land management: an agenda for improving tenure security and urban governance in poor countries. *Habitat International*, 24(2), 231-240.
- Marshall, S., Taylor, W., & Yu, X. (Ed.) (2003). *Closing the digital divide: Transforming regional economies and communities with information technology*. Westport CT, Greenwood Publishing.
- Muraya, P. W. (2006). Failed top-down policies in housing: The cases of Nairobi and Santo Domingo. *Cities*, 23(2), 121-128.
- Payne, G. (2001). Urban land tenure policy options: titles or rights? *Habitat International*, 25(3), 415-429.
- Oliórtégui, I. (2001, May). Informal settlers in Lima. In *Workshop Paper, ESF/N-AERUS International Workshop*, Leuven and Brussels, Belgium.
- ONGEI (2014). National Office of Electronic Government and Informatics, Peru. Retrieved 5 July 2014. Available from [www.ongei.gob.pe](http://www.ongei.gob.pe).
- Poerbo, H. (1992). Government and land ownership cooperation: guided land development in Indonesia, conceptual approaches. *Triang*, 32, 26-29.
- PRONA (2014) Programa Nacional de Asistencia Alimentaria. Retrieved July 3, 2014 from <http://www.midis.gob.pe/index.php/es/pronaa>
- RCP (2014) Red Científica Peruana. Retrieved August 6, 2014 from <http://www.rcp.net.pe/historia.html>
- Riley, B. (2001). *Electronic Governance and Electronic Democracy: Living and Working*. In *The Connected World Vol 2*. Brisbane, Australia: Commonwealth Centre for Electronic Governance.
- Riofrío, G. (2003). Urban slums reports: the case of Lima, Peru. *Understanding slums: case studies for the global report*, 15.
- Sahley, C., and Danziger, J. (1999). *Rising to the Urban Challenge? The Roles, Strategies and Performance of NGOs in Lima, Peru*. United Kingdom: Intrac.
- Sakay, C. (2012). *The Generational Self-help Housing and the Construction Process towards the Creation of a New City*. Unpublished master dissertation, University of Tsukuba, Japan.
- Sakay, C., Sanoni, P., and Hanazato, T. (2011). Rural to urban squatter settlements: the micro model of generational self-help housing in Lima-Peru. *Procedia Engineering*, 21, 473-480.
- Sakay, C., and Hanazato, T. (2011). Self-help housing builders in squatter settlements: The case study of Manchay-Peru. Paper presented at The 24th World Congress of Architecture, UIA, Tokyo, September.
- Sanoni, P (2012). Organizational network for delivery of public health care services in rural areas of Peru using information and communication technologies (ICT). *The Journal of International Public Policy*, The University of Tsukuba. 30, 101-138.
- Sheng, Y. K. (1990). Community participation in low-income housing projects: problems and prospects. *Community Development Journal*, 25(1), 56-65.
- Skeates, R. (1997). The infinite city. *City*, 2(8), 6-20.
- UNCHS (1991). *Human Settlements Development through Community Participation*. Nairobi: United Nations Centre for Human Settlements, Habitat.
- UNDP (2003). *Human Development Report 2003, Millennium Development Goals: A Compact among Nations to End Human Poverty*. New York. Oxford Press.
- UN-Habitat (2007, April). *Sustainable urbanization: Local Action for Urban Poverty Reduction, Emphasis on Finance and Planning*. Presented at Twenty First Session of the Governing Council. UN-Habitat, Nairobi, Kenya.
- World Bank (1998a). *Project Appraisal Document, Report No. 18245PE*. Peru - Urban Property Rights Project, Washington D.C
- World Bank (1998b). *Project Information Document, No. PID6523*. Peru - Urban Property Rights Project, Washington D.C.
- Wheeler, J. O., Aoyama, Y., and Warf, B. (Ed.). (2000). *Cities in the Telecommunications Age: The Fracturing of Geographies*. London, Psychology Press.

## Endnotes

1. Facebook user: "Municipalidad Distrital de Pachacamac" (redirected to the official website of the Municipality of Pachacamac <http://www.munipachacamac.gob.pe/>)
2. COFOPRI official web site <http://www.cofopri.gob.pe/> last visit August 2nd, 2014.
3. Facebook user: "Manchay, Lima, Peru" (22,880 visits), last visit August 10th, 2014.





# Part 2

## COLLABORATIVE URBAN POLICYMAKING



Community meeting discussing reconstruction of village hit by volcanic eruption.  
Yogyakarta, Indonesia. © World Bank/Nugroho Nurdikawan Sunjoyo



# Planning Support Systems as Collaborative Planning Enablers

○ Giulia Melis

SITI – Higher Institute on Territorial Systems for Innovation, Politecnico di Torino, Italy

## Abstract ○

The chapter explores how new digital tools, planning support systems and visualization tools in particular, incorporated in participatory processes, can be helpful in fostering the dialogue between planning practitioners, citizens and decision makers, in order to start a collaborative process. Starting from the achievements and use of ICT tools in developed countries for processes of “citymaking”, it analyses how such tools can be adapted in the context of developing countries, which challenges should be

taken into account and what would the role of each actor in the process be, with a special focus on Africa south of the Sahara. The chapter shows that current technologies and tools offer new methodologies to support collaborative planning processes, able to encourage a shift from the smart city to the people-friendly city, towards an enhanced quality of life of citizens, as well as transparency and accountability of local governments.

### Keyword:

collaborative planning, visualization, people-friendly city, planning support system, urban living lab.

## Introduction

The current literature on information and communication technology and planning suggests that use of the technology in local government can enhance the management and functioning of cities, introducing to them new opportunities for a sustainable growth.

A deeper knowledge of ongoing phenomena is enabled by big data and city sensing. The increasing use of web-based and open-source geographic information system applications raises awareness of spatial issues that impact on the local environment, while interactive mapping provides opportunities for dealing with spatial concerns, virtually.

This integration of information systems in urban areas has generated the concept of the “smart city”, promoting a technology driven vision: this quantitative approach, however, contrasts with the social and qualitative origins of urban co-living. As a result, citizens are far from benefitting from smart technologies within urban areas. Nowadays the debate is finally shifting towards a more human dimension, introducing the concepts of people friendliness and human-to-human approach. In this chapter, we will explore how new digital tools, planning support systems and visualization tools in particular, incorporated in participatory processes, can be helpful in fostering the dialogue between planning practitioners, citizens and decision makers, in order to start a collaborative process. We will also discuss how lessons learnt from European applications can be translated to the context of emerging countries.

Even if most of the literature focuses on the experience of developed countries, where capacity and resources permit a sophisticated understanding of ICT, experiences and case studies suggest that these tools have also been tested in some developing countries - with India often cited as one of the leading countries in achieving ICT prominence - but little seems to be published about this experience in Africa south of the Sahara. There are a number of innovative initiatives under way in African local governments, even if most of them are in their initial stage. In contrast, there are a number of examples in developed countries that may provide some guidance for developing cities.

In this chapter, we will explore the application of ICT to planning support tools, focusing on the process of involvement and empowerment of citizens as energetic actors in urban living labs, using crowdsourced data in planning support tools. Starting from the achievements and use of ICT tools in developed countries for processes of “citymaking”, we will try to analyse how such tools can be adapted in the context of developing countries, which challenges should be taken into account, and the role that each actor would play in the process.

## Background

### Cities: Smart or People Friendly?

The concepts of “smart city” and e-governance are well rooted in Western countries, and they have been marking the path in the last years, becoming almost a label for promoting the city image in the global competitive arena.

# 2.5 BILLION

The number of mobile phones that big communication companies have sold in developing countries in recent years due to a decrease in prices

In the last decades, in order to respond to the major urban challenges which call for a transformation in the way of working and living together, the smart city idea towards sustainable growth and well-being has taken the stage, suggesting that a smart city is a place where whatever interaction is mediated by technologies. This technology-driven vision has recently been criticized, moving the focus from the cities to the people: as Hemment and Townsend declared in the foreword of a recently published volume on this issue (Hement & Townsend, 2013), the focus should be moved from “smart cities” to “smart citizens”.

All across Western countries, new visions are emerging which recall the concepts of “people friendly cities”, or “human smart city”: they put the human perspective as central, and promote the application of citizen-centric and participatory approaches to the co-design, development, and production of places and services in the city (Glaeser, 2011; Gibbson, 2011). In their vision, which we embrace, the technical “smartness” of sensors, meters, and infrastructures as traditionally proposed in the smart cities concept, should find a balance with softer features such as clarity of vision, citizen empowerment, social interaction in physical urban settings, and public partnership. This approach focuses on people and their well-being, having the quality of life as its central goal: the city has to learn how to self-organize its smartness; it is aware that citizens are not only intelligent but also accessible and able to make their city a place with an infinite variety of choices.

## New Opportunities for Participation

Two technological developments are of special interest in this regard. First, the rise of “big” and “open” data, in combination with the opportunity to generate data through sensor networks in a bottom-up



THIS INTEGRATION OF INFORMATION SYSTEMS IN URBAN AREAS HAS GENERATED THE CONCEPT OF THE “SMART CITY”, PROMOTING A TECHNOLOGY DRIVEN VISION: THIS QUANTITATIVE APPROACH, HOWEVER, CONTRASTS WITH THE SOCIAL AND QUALITATIVE ORIGINS OF URBAN CO-LIVING.



way, provides citizens with new ways to map, analyse and deal with salient urban issues. Second, the usability of social media platforms allow for the bottom-up mobilization and organization of the public around particular issues. Taken together they hold the promise of stimulating new forms of “ownership” as an “inclusive form of [citizen] engagement, responsibility and stewardship” (de Lange & de Waal, 2013).

Citizen participation is thus changing; from being simply considered users of urban services, citizens are, increasingly, becoming key actors in the services conception and production. From being users, citizen becomes co-designers and co-producers of urban services; they become main engines of the innovation process because they act to solve their own problems (Periphéria project, 2013). Digital innovation ecosystems are emerging based on citizen-driven approaches (socio-digital innovation ecosystems) such as living labs, where co-design methods are able to tap the creative potential of local territories. In living labs first application, that is the industrial context, development takes place in the environment in which the products or services will eventually be implemented, and they are developed in close cooperation with various stakeholders. Especially in Europe, the concept of the living lab has recently caught on, as the European Network of Living Labs witnesses with more than 340 cases connected in 2014.

Urban living labs are a peculiar application in urban local contexts of this methodology, as a way of developing (urban) environments, services or practices. Five phases, or central issues, to be addressed in the process have been identified by de Waal and Melis (in press):

- setting the stage and naming the issue visualizing the issue

- engaging a public around the issue ideation and prototyping resolution and institutionalization.

Urban living labs are thus presented as a way to overcome the top-down bottom-up dichotomy found in recent debates on city planning. The living lab approach could be seen as a way to reconcile the top-down, structural and institutional approach of smart citizens with often small-scale and one-off bottom-up initiatives of community groups, artists and citizens (Almirall & Wareham, 2008; Baccarne et.al, 2014; Coenen et al., 2014).

The issue of participation, in fact, is an intrinsic characteristic of urban living labs: when labs are run to improve quality of life in a particular area, rather than just testing out a prototype of a product, in principle every resident is entitled to participate in the lab. However, as Friedrich et. al. point out, it is usually not practical to involve all residents in living lab sessions. They suggest that an active effort must be undertaken to identify what stakeholders are to be engaged, especially citizens for “whom the planned changes are highly relevant and whose own life will be affected by the changes, but who are typically not active participants in civil society” should be involved in some way or another (Friedrich et al., 2013). In some cases, however, wider public involvement is crucial in a second phase, when the problem has been defined and some solutions have been proposed, in order to achieve a critical mass sometimes essential to the implementation of the process, especially when it is public-initiated.

The role of ICT and social platforms is of outstanding importance in this phase, as it facilitates the spread of ideas and collection of opinions,



Passengers use their mobile phones in a subway train. Mobile phones and tablets are used for people to entertain and view information when they take public transportation. © Shutterstock





DIGITAL INNOVATION ECOSYSTEMS ARE EMERGING BASED ON CITIZEN-DRIVEN APPROACHES (SOCIO-DIGITAL INNOVATION ECOSYSTEMS) SUCH AS LIVING LABS, WHERE CO-DESIGN METHODS ARE ABLE TO TAP THE CREATIVE POTENTIAL OF LOCAL TERRITORIES.



that is to say the birth of a public debate, around the proposed issue. ICT plays an important role in connecting people and developing projects and ideas, due to the high potential of connection, especially when the issue deals with many stakeholders or involves an area where potentially numerous residents are touched by the problem.

### Potential of ICT in Developing Countries

Actual data on the growing diffusion of mobile devices and ICT in developing countries, especially in Africa south of the Sahara, suggest that the stage is ready for using those resources to enable people to participate, through processes of urban living labs and facilitating tools and support of visualization, in the process of citymaking of their own living places.

In recent years, a decrease in prices has allowed big communication companies to sell over 2.5 billion mobile phones in developing countries, nearly doubling the number of mobile subscribers worldwide (ITU, 2011). In 2012, the rich world finally delivered an affordable computer to the developing world, with smartphone prices in Kenya under USD100. Worldwide, smartphones, rather than cheap laptops, are destined to be the true face of ubiquitous computing (Townsend, 2013). Beside this, many projects have been developed, out of the market logics, to meet the needs of people who have reduced access to technological innovations, such as low-cost laptops and netbooks (project One Laptop per Child, developed by MIT), or the Fairphone project (supporting sustainable and ethic production).

Developing countries have long struggled to build ubiquitous wired networks. Wireless networks have proven to be faster to build and secure from thefts of copper wire, allowing the benefits of connectivity to be quickly brought to large numbers of people. While the cost of building fibre-optic networks is thousands of dollars per home, delivering broadband wirelessly can cost one-fiftieth that much. As a result, 80 per cent of the world's mobile broadband subscribers are in developing countries. Wireless is the infrastructure of inclusion (Townsend, 2013).

With the basic infrastructure of smartphones and mobile broadband in place, there has been also an explosion in services aimed at the poor. Some examples are the Indian mobile app called Babajob, a

SMS-based social network for the millions of people working in the country's informal sector, described by a tech blog as "LinkedIn for villages", or Mapunity, which emulates Google's sophisticated mapping services using people's mobile devices to sense traffic speed through phone movements and taxi radios.

However, mobiles are not simply new economic tools for the world's urban poor. Increasingly, mobile networks themselves are becoming observatories where one can watch in real time how people move, how cities grow, the quality of life, and economic activity. Urban sensing is delivering a huge set of data unexplored before the advent of GPS tracking on mobiles; opening up data is stimulating different researches, in developed as in developing countries.

Data sensed by mobiles have been used in interesting anthropological and social studies. One study tracked migration in the slum of Kibera, in Kenya's capital, uncovering an unexpectedly high turnover rate for new arrivals in the slum (Wesolowski & Eagle, 2010), while anthropologist Mirjam de Bruijn (2013) has documented Bedouin caravans in the southern Sahara that have altered their historic trade routes to pass, periodically, through areas of mobile phone service.

As concerns the "networked public sphere", as Yochai Benkler (2006) calls it, some interesting experiences have been reported, pointing out how the information environment is characterized and empowered by the potential for many-to-many communications (instead of just one-to-one or one-to-many, as in traditional media), and the near elimination of the cost of communication.

Most case studies across Africa south of the Sahara report small-scale projects by non-governmental organizations using SMS for activism and advocacy. Ekine (2009) presents accounts of specific campaigns in the Democratic Republic of Congo, Kenya, Nigeria, South Africa, Uganda and Zimbabwe, with examples of resource kit for human rights activists, alternative news sources to counter government censorship, and success by leveraging media attention.

Among those experiences, the tool Ushahidi is particularly valuable and offers opportunities to be used not only for crisis responses around the globe, but also for involving the public in the care for common urban places. Ushahidi (which means "testimony" in Swahili) began in response to the Kenya's post-election violence in 2007 (Okolloh, 2009). It documented the geographical distribution of incidents of violence, allowing those with Web access to see a composite map of the unfolding crisis. The system provides an open-source platform for collecting individual reports from users through SMS, Web and email, and provides tools for translating, classifying, and georeferencing these reports. The newest version of the platform further allows for submission via voice message, which is essential for illiterate users. Aggregated information is presented on a map-based interface accessible via Web and mobile phone.

Besides being a tool for aggregating citizens, it shows how visualization can play an important role in mobilizing the public around an issue,

when information is relayed in “a visually compelling way”. (Goldstein & Rotich, 2008-09). An interactive map is a remarkably effective narrative tool for a transnational audience.

## Participation in Urban Planning: Why and How

### Urbanity in Africa South of the Sahara

According to UN-Habitat (2012), an estimated 91 per cent of the expected increase of the world’s urban population will take place in developing countries. Large urban configurations come with a number of well-identified, specific risks: poor urban and regional planning, lack of coordination and deficient coping strategies in the face of social and fiscal disparities (UN-Habitat, 2012). Although Africa south of Sahara is home to some 900 million people, it is estimated that more than half of this population will be living in cities by 2030 (AfDB, 2011) with its infrastructure woefully inadequate to support these lives. In a region of 54 countries, 28 of these were listed among the world’s 30 least developed having more than two-thirds of its people living on less than USD 2 dollars per day (Kieh Jnr, 2008). Though urbanization in this region of Africa seems to have an exponential growth, the corresponding development to support it is still inadequate. Policies of spatial decentralization of many African countries, which favour smaller cities, as well as investment and planning decisions have contributed immensely to the growth of medium-sized cities, which have been growing faster than the largest ones (Kieh Jnr, 2008). More so in developing countries, especially in Africa south of the Sahara, urbanization and city development are characterized by an “international demonstration effect”, whereby national surpluses (if any) are wasted by elite purchases of fashionable consumer goods rather than being used to stimulate the local economy.

With the current unprecedented population growth, the increase rate of urbanism and the advent of the post-oil economy in Africa south of the Sahara, cities are experiencing growth pains. Major criticalities in these cities include air and water pollution, congestion, noise, urban sprawl, overburdened infrastructure, inadequate public services, and the social consequences of unaffordable housing, underemployment, crime, and the underprivileged. Rising concerns about global climate change over the past decade have also elevated energy consumption and carbon dioxide emissions to the top of the list of urbanization challenges (Hodgkinson, 2011). One could legitimately ask, “Why would influx of oil-economy create growth pains?” The lack or absence of well-prepared development plans and agenda to utilize these financial influxes can worsen the already existing problems without providing any meaningful solution (Marful, 2014).

### Urban Living Labs and e-Participation

As a way to respond to those needs, in a context where local institutions seem to lack the ability to propose solutions, citizens can encourage change and take action from the ground to participate in the citymaking process.

According to de Bouw et al. (2013) and Townsend (2013), there is the promise of new media technologies as a tool to empower citizens politically to become active agents of change in their cities.

The implementation of e-collaboration and e-participation platforms based on virtual 3D city models could support efficient workflows, data exchange, and data reuse between the actors (government, citizens, private parties). Moreover, it could raise transparency and accountability in environmental planning and ultimately foster civic engagement, as Tiwari and Jain (2013) report in their study.

Worldwide, within professionals and researchers concerned with city planning, there is an increasing interest in the involvement of citizens and other stakeholders. Approaches such as communicative, collaborative or participatory planning and the use of crowdsourcing recognize that, as the American Institute of Certified Planners says in its 2009 professional code, planners shall aspire to “give people the opportunity to have a meaningful impact on the development of plans and programs that may affect them” (Seltzer & Mahmoudi, 2013) .

This development is related to a broader shift in the concept of planning itself. It is undergoing a cultural transformation, from designing the physical urban environment as an efficient, static backdrop for living, towards the concept of “citymaking” (de Waal and Melis, in press). This means that planning is no longer just a decision-making process about the physical organization of the city. Rather, it is progressively including cultural aspects, liveability and social cohesion issues, and community building; which is leading the process of planning to be opened up to various stakeholders.

Living labs are, in fact, characterized by the presence and active role in the process of institutional organizations (that is government and its agencies), private sector (as investors or developers), and concerned citizens. One of these three parts can start the process, according to the urgency and commitment to a particular problem, and organize the involvement of the others in order to find a common solution.

### Visualization Tools and Urban Data

The interest in using new media and visualization tools to involve citizens in planning is not completely new. Starting from the end of the 1980s, due to the rapid development of graphic interfaces and microsimulation systems, a variety of new instruments has emerged as support tools to manage urban complexity and planning decisions, involving non-expert audience: they range from electronic conference board rooms that is group decision support systems- (Laurini, 1998), and GIS-supported collaborative decision-making tools (Nyerges & Jankowski, 1997), to web-based mediation systems for cooperative spatial planning (Gordon et al., 1997) and support tools for different planning tasks (Geertman, 2002).

Commonly defined as planning support systems, these tools have been largely developed in order to find new methodologies for approaching urban planning processes. Nevertheless, their few applications in real contexts outlined different limitations to their usability. In general, as reported by Te Brommelstot (2010), the family of these support systems are seen by their intended users as “inadequate, far too generic, complex, too technology oriented (rather than problem oriented), not transparent enough, neither flexible nor user-friendly,



too narrowly focused on strict technical rationality, and incompatible with the unpredictable/flexible nature of most planning tasks and information needs” (Bishop, 1998; Couclelis, 1989; Geertman & Stillwell, 2003; Harris & Batty, 1993; Lee, 1973, 1994; Sieber, 2000; Uran & Janssen, 2003; Batty, 2003; Vonk, 2006). This list highlights how the increasing computational capabilities have not been able to solve most of these bottlenecks, which involve mainly social and communicative aspects.

In order to promote the practical application of planning support systems, a more inclusive and people-friendly approach is being developed (Melis et al., in press), and there are proposals for the systems to be included in the process as facilitating tools, recognizing their importance in making issues more understandable, but not considering them as a panacea for collaborative planning.

Anyway, if they are combined as supporting tools in a process expressly designed to engage stakeholders in the solutions design, as the urban living lab presented in the previous paragraph is, potentially they could make them more understandable to non-expert public to be fully exploited.

We would like to discuss here the potential success urban living labs could have in African cities south of the Sahara: unlike planning support systems, citizens would play an important role, either as (mostly) co-creators, or (sometimes) as initiators of the process, shaping it and its tools according to their needs and capabilities.

Even if current trends on opening up data from city governments are gaining the stage, one can hardly consider this release to the public sufficient to make them aware of some complex issues, for example on decisions regarding the urban environment. To be useful, these data need to be presented in easily accessible and understandable ways. Initiatives led by citizens worldwide have experimented how graphical representation of public information could lead to changes in public opinion, encourage debate and bring changes in legislation.

Participatory action research and design, as described by Bødker et al. (1988) and Ehn (1990), include shared analysis of common data as one of its critical parts. However, in order to be successful such a process should be designed according to the existing communicative ecology of its users, who are city inhabitants (Moere & Hill, 2011). Locally relevant information should be visible and placed in accessible areas, in addition to being spread through media (news, mails, social networks, etc). The public visualization of urban data could play an important role in providing a better understanding of a place, as it has already been shown that, by combining existing data repositories with real-time sensor measurements and qualitative citizen feedback, valuable alternative views of the city could be created, potentially even in real-time (Calabrese et al., 2007).

Such representations typically aim to reveal the salient patterns of urban living or make the impact of urban activities and their regulation understandable, such as to produce original insights into the nature of

the contemporary city (Read and Pinilla, 2006), to model and simulate the city digitally (McGrath, 2008), or to investigate the spatio-temporal actions and opinions of city inhabitants (Vaccari et al., 2009).

The resulting visual representations of the city still tend to be presented on dedicated media such as websites or smartphone applications. Yet Moere and Hill (2011) note that it is fundamental to have, also, a physical installation in order to overcome the conceptual as well as physical separation from the actual environment from which the data originates, which present the risk of turning the urban experience into a virtual one. They present recognition of implemented projects which use the persuasive ability of technology, proving that visualization of public data can change behaviour and educate people.

The Tidy Street project (Bird and Rogers, 2011) in the United Kingdom is a quite simple and inexpensive one that was successful in motivating the local community to participate in lowering energy consumptions. This project relied on data collection on one side, about energy consumption for each household in the street, and data visualization on the other. Each week a graph was drawn with coloured chalks on the street surface, thus making it possible to compare residents’ consumptions (gaming) and beckoning interest from pedestrians, who gathered information on the experiment and energy efficiency (education, awareness raising). Urban living labs could offer a concrete environment, in addition to the virtual, as an arena for visualization and debate around specific issues.

Local government plays a key role in the process of urban living labs, as it represents the institutional face of the public sphere. This kind of process stimulates a more proactive and inventive participation, which helps public officers in being closer to their citizens and learning to listen to them. At the end of the process, government gains because the city’s image is enhanced, which relies on unique or outstanding characteristics able to promote the city towards place marketing: the city could label itself as smart and people friendly, able to conduct consultation and participation with communities, allowing for continuous two-way communication between city governments and their constituents (Odendaal, 2003). This, in some instances, is often associated with greater transparency in decision-making. All these features make the city attractive and competitive, fostering economic activities, attracting investment and visitors.

## Unequal Access to ICT

Information and Communication Technology is a fundamental tool in the process of a sort of crowdsourced urban living lab, created, fed and designed by or with citizens. However, account must be taken of views that the impact of ICT is ambiguous in that “it unifies but also divides, it may level the playing fields in some instances, but it also brings about inequality” (Frissen, 1997).

Several case studies reported by Eagle (2009) point to the unequal access to ICT in Africa. Eagle (2009) shows how the cost of mobile communication often prohibit mass participation, even in short message service (SMS) campaigns: economic and regulatory context often allow some mobile operators on the continent to reap huge profits,

and regulation seldom serves the public good. Political exploitation of telecommunications is also documented, for governments to expand their influence. According to Christian Kreutz (2009), the potential contributions of mobile technologies (such as expanding participation in citizen media) are limited “(1) by the costs of airtime, which strangles participation in SMS campaigns; and (2) by the cost of handsets, which means that old or low-cost phones are the norm”, and thus limits access to other features, such as data and applications.

On the other hand, another view is offered by Kibora’s study (2009) of SMS use in Burkina Faso. The study documents the mass mobilization of SMS in everyday communication in urban and rural areas, despite lack of access to cell phones and literacy. Discarded phones are recovered from European dumps and exported to Burkina Faso, where they suggest modernity, utility, and business opportunity. Even in remote village communities, SMS scribes are recruited. Written language and asynchronous text messaging are used to bypass costs and difficulties with network access, but traditional norms for oral interaction (such as hierarchical speech) persist.

Currently, 59 per cent of people in Africa are still non-users (ITU, 2010) of mobile phones. Although these people may not appear particularly newsworthy or remarkable, they nonetheless present an equally important group of research participants.

In this regard, Carter (1997) refers to the potential deepening of the relationship between the information haves and have-nots who may emerge if access to information technology and its benefits are not achieved. If ICT were to facilitate democratic and inclusive governance, it would need to bridge the digital divide, directly. The “on the ground” context in terms of cultural and social make-up of its constituents and capacity that exists in terms of skills and literacy, would most certainly impact (Borja & Castells, 1996). If ICTs are to function as tools for advancement in developing and developed countries, then skills growth and improved access would be vital in achieving this goal. Underlying this technical development is the importance of social development - literacy training, public computer access, and creating opportunities for participating in the information technology industry.

## Overcoming the Barriers

Humans are becoming an urban species, living in a large number of vast agglomerations. Cities around the world face various challenges, as the fast changing demands of demographics, mobility, energy consumption, quality of life, crime dynamics, economics, resource use, waste, culture production, and consumption dictate. While most citizens are becoming increasingly aware of the environmental, societal and economic challenges that surround modern urban living, only few might comprehend the driving principles behind these problems, let alone reflect upon how these affect the reality of their own daily lives. Understanding and reflecting upon such urban problems is complex because of the huge quantity and variety of interrelated parameters that influence these phenomena and their inherent dependence on the local context and sensitivities of a given location. No two cities in the world, or even two neighbourhoods within the same city, are

identical in the issues that residents face. Solving urban problems now requires taking into account the cultural, environmental, legal, or societal reality surrounding a specific place in which the subjective experience and opinions of citizens are becoming as important as the physical manifestation of buildings and public services in the urban landscape. However, more localized decision-making typically requires higher resolution information gathering, in terms of quantitative measurements of the environment, but also in terms of collecting qualitative feedback from the very people who actually have to coexist with, and within, these data.

In order to gain a truer understanding of the influencing principles and tendencies behind growing cities, one should consider how to make stakeholders — that is residents — better aware of the true nature of urban challenges. By involving the local population in understanding the driving principles behind current urban issues, more widely adopted and competent actions such as those induced by legislation and policies would stand a greater chance of improving the quality of life of city residents, especially when part of the solution requires these residents to change their ways of living (as sustainability issues).

In order to get the implications of this changing nature of a city, a neighbourhood, or a street, one could view this through the lens of urban data, in the form of real-time digital traces of urban activities, as well as their qualitative impact on the local environment. By sharing this information through an expressive and socially shared medium such as a public display, one expects a sense of responsibility toward a place could be reinstated, which might even have the potential of changing local habits, attitudes, or behaviours. In the language of urban planning and urban design, this might even become a new form of placemaking.

Through urban living labs, this process could be enhanced and organized, keeping sensitive data close to the people who generated them, and enabling these people to use their own information for improving the urban quality of their surrounding environment. To do this, equal access to ICT resources as well as to education is required and pursued by local governments.

Furthermore, open access to public data encourages greater transparency and good governance, which is particularly needed in the context of local and national governments in Africa in order to counter corruption.

The process of citizen involvement, promoting decision-making that favour consensus-driven, horizontal relations was recognized by Frissen (1997) as able to contrast traditional hierarchical structures of command that characterize many city governments. The adoption of urban living labs and planning support systems in order to have better informed and more transparent decisional processes could benefit the form of government in Africa.

## Living Labs in Developing Countries

We will try here to delineate steps to be undertaken for setting up an urban living lab. For each one of those, different engagement techniques could be adopted, depending on the means, the actors

and their skills, ranging from those that are very simple to one that more technology oriented.

We present here the stages for setting up a living lab, which are adapted and merged with Murray et al. (2010) stages of social innovation. These steps described are not always sequential, as their order may change according to specific needs, and they can also be thought of as overlapping spaces, with distinct cultures and skills. The steps include the following:

**Setting the stage and naming the issue:** some situation and context has to be prepared before activating the process. This is the moment at which it is necessary to identify the possible stakeholders and if there is a real possibility and will to innovate.

**Visualizing the issue:** The problem has to be translated into simple language, comprehensible to everybody; main points and stakes should be clear. Visualization could be useful at this stage, as it helps in making the issue as simple as possible. This stage involves diagnosing the problem and framing the question for a particular and contextualized situation.

**Engaging a public around the issue:** once the problem is defined by its initiators, more public and interested players can be engaged. Additionally, in this case, traditional communication as well as more innovative campaigns could be used for the same purpose. In a country where the majority of people have access to the Internet and are familiar with information retrieval, posting data and creating a website, this could be a good solution. Otherwise, other media should be used to reach a wide portion of public, through newspapers, posters and by word of mouth.

**Ideation and prototyping:** This represents the level at which ideas are generated, and successively tested in practice. The process could be different in every context, but this stage allows different partners or stakeholders to collaborate through iteration, as well as by trial and error, thus making stronger the link among them.

**Resolution and institutionalization:** the solution tested and refined, should then become every day practice. Ideas would be sharpened to identifying and ensure the future sustainability of the services that would carry the innovation forward. Attention should be paid to set a ranging of strategies for growing and spreading the solution.

Visualization plays a crucial role in supporting the process, as it helps to engage the non-expert public. Thus one should not think only about ICT and advanced programmes for 3d modelling, which would find an appropriate public in developing countries. Rather, one should also consider simpler ways of communications, through performances in the public space, art installation, places where people could express their ideas in different ways. Having also online contents may help spreading ideas, and it may be more appealing especially for youngsters: as living lab is an open laboratory, we suggest each participant contributes their skills, exchanging knowledge and building capacity in their own community.



SOLVING URBAN PROBLEMS NOW REQUIRES TAKING INTO ACCOUNT THE CULTURAL, ENVIRONMENTAL, LEGAL, OR SOCIETAL REALITY SURROUNDING A SPECIFIC PLACE IN WHICH THE SUBJECTIVE EXPERIENCE AND OPINIONS OF CITIZENS ARE BECOMING AS IMPORTANT AS THE PHYSICAL MANIFESTATION OF BUILDINGS AND PUBLIC SERVICES IN THE URBAN LANDSCAPE.



## Research Gaps and Further Steps

This chapter proposes some considerations, supported by literature, about the wide benefits that application of urban living labs could have in developing countries; and Africa south of the Sahara in particular. However, no experience until now has been implemented on the ground (and labelled as that), though many initiatives of co-design and participatory planning have been started, as well as citizen involvement though ICT. It is like witnessing that every piece is there, but the puzzle still needs to be put together to form the complete figure. Even in Europe this kind of approach is still in its infancy, even if literature and reports show interesting opportunities. The economic crisis in developed countries has given a push to these bottom-up initiatives, in contexts where traditional powerful actors have started to disappear from urban planning processes. That is why this process could adapt and also flourish in developing countries, even if field testing still needs to be done.

Some gaps still need to be closed: is the "networked public sphere" really accessible by everyone? Can the Internet really be counted as a "common" on a continent where only a small part of its population can access online media? Similarly, the constraints and high costs of SMS make a need for accessible online "public spaces" and cheap mobile. Efforts are being made towards this, but opportunities to access online platforms are still not the norm for most Africans. Social changes accompanying and resulting from uneven adoption of mobile communication may lead to increased levels of exclusion and inequality, as well as to enhanced participation.

## Conclusion

The chapter shows that current technologies and tools offer new methodologies to support planning processes. Communication between developers and practitioners, as well as the interaction between the actors involved in the processes, could be enhanced by the way processes are structured and tools are applied. The application of urban living labs supported by planning support systems shows that a shift from the smart city to the people-friendly city is encouraged, using data to implement planning processes and, consequently, the

quality of life of citizens, ensuring transparency, accountability and public participation.

In general, the broad adoption of the Internet around the world has enabled a new class of participatory systems that allow people to contribute, share information and work together in real time (Eysenbach, 2008).

Furthermore, engaging the public transforms users from passive recipients of information to active participants in a collaborative community, helping to improve their own environment and quality of life. "The ability of small-scale initiatives in cities and regions to

use advantages of the technologies, to use cyberspace, to create communication and activity networks free from the usual spatial and temporal constraints is a crucial element in providing a democratic counter-balance to other technological and global trends." (Carter, 1997: 151–152).

The potential in achieving that in developing countries is very exciting, but it also poses serious challenges, given the constraints that need to be overcome to ensure access and exposure to the potential empowerment properties of ICTs. Local government, in its role as facilitator of development, would thereby have a key role to play in fostering this process.

## References

- AfDB (2011). Africa in 50 Years Time. The Road Towards Inclusive Growth, African Development Bank (ADB) (Tunisia, Tunis), September 2011, p.13.
- Almirall, E., and Wareham, J. (2008). Living labs and open innovation: roles and applicability. *eJOV: The Electronic Journal for Virtual Organization & Networks*, 10
- Baccarne, B., Mechant, P., Schuurma, D., De Marez, L., and Colpaert, P. (2014). Urban socio-technical innovations with and by citizens. *Interdisciplinary Studies Journal. Special Issue on Smart Cities*, 3(4)
- Batty, M. (2003). Planning support systems: technologies that are driving planning'. (S. Geertman, and J. Stillwell, A cura di) *Planning Support Systems in Practice*, v - viii.
- Benkler, Y. (2006). *The Wealth of Networks: How Social Production Transforms Markets and Freedom*. Yale University Press.
- Bird, J., and Rogers, Y. (2010). The pulse of tidy street: Measuring and publicly displaying domestic electricity consumption. In *Workshop on Energy Awareness and Conservation through Pervasive Applications (Pervasive 2010)*.
- Bishop, I. (1998). Planning Support: hardware and software in search of a system. *ComputersEnvironment and Urban Systems*, 22, 189-202.
- Bødker P., Ehn J., Kammersgaard M., Kyng M. & Sundblad Y. (1988). A Utopian Experience, in Bjerknes G.et al.(Eds.), *Computers and Democracy: A Scandinavian Challenge*, Williston, VT: Avebury.
- Borja, J., and Castells, M. (1996). *Local and global: management of cities in the information age*. Earthscan: London.
- Bouw, M., de Lange, M. and de Waal, M. (2013). De hackable wereldstad. In J. Lekkerkerker, & S. d. Vries (Eds.), *Ruimtevolk jaarboek 2013. nieuw kapitaal* (pp. 163-167) Ruimtevolk.
- Calabrese, F., Kloeckl, K., and Ratti, C. (2007). Wikicity: real-time urban environments. *IEEE Pervasive Computing*, 6(3), 52-53.
- Carter, D. (1997). Economic regeneration and the information economy. *The governance of cyberspace: Politics, technology and global restructuring*, 136.
- Carter, D.(1997). 'Digital Democracy' or 'information aristocracy'? Economic regeneration and the information economy. In B. D. Loader (Ed.), *The governance of cyberspace: politics, technology and global restructuring*. London: Routledge.
- Coenen, T., Graaf, S. v. d., & Walravens, N. (2014). Firing up the city - A smart city living lab methodology. *Interdisciplinary Studies Journal. Special Issue on Smart Cities*, 3(4), 118-128.
- Couclelis, H. (1989). Geographically informed planning: requirements for planning relevant GIS. 36th North American Meeting of Regional Science Association. Santa Barbara.
- de Bruijn M. E. (in press). Mobile Telephony and Socio-Economic Dynamics in Africa, in Ingram G.K. & Brandt K.L. (Eds.), *Global Infrastructure: Ongoing realities and emerging challenges*, Cambridge, MA: Lincoln Institute for Land Policy.
- de Lange, M., and de Waal, M. (2013). Owning the city: New media and citizen engagement in urban design. *First Monday*, 18(11)
- de Waal, M., & Melis, G. (in press). Urban Living Labs & Citymaking: Open innovation and urban design. In Cohen, B. & Almirall, E. (Eds.) *Open Innovation as a driver for Smart Cities*, Springer.
- Eagle N. (2009). Economics and power within the African telecommunications industry, in Ekine, S. (Ed.), *SMS Uprising: Mobile Phone Activism in Africa*. Cape Town: Pambazuka Press.
- Ehn P. (1990), *Work-Oriented Design of Computer Artifacts*, Amsterdam: Lawrence Erlbaum.
- Ekine, S. (Ed.) (2009). *SMS Uprising: Mobile Phone Activism in Africa*. Cape Town: Pambazuka Press.
- Eysenbach G. (2008). Medicine 2.0: Social networking, collaboration, participation, apomediation, and openness. *J Med Internet Res*, 10: e22.
- Friedrich, P., Karlsson, A., and Federley, M. (2013). Report 2.1 boundary conditions for successful urban living labs. SubUrbanLab project report. Retrieved July 2014. Available from <http://jpi-urbaneurope.eu/wp-content/uploads/2014/01/Report-Boundary-conditions-for-successful-Urban-Living-Labs.pdf>
- Frissen, P.(1997). The virtual state: postmodernisation, informatisation and public administration. In B.D. Loader (Ed.), *The governance of cyberspace: politics, technology and global restructuring*. London: Routledge.
- Geertman, S., and Stillwell, J. (Eds.). (2003). *Planning Support Systems in Practice*. Berlin, Germany: Springer.
- Gibson W. (2011). Life in the Meta City, *Scientific American*, September, 88-89.
- Glaeser E. (2011). Engines of Innovation, *Scientific American*, September, 50-55.
- Goldstein, J., and Rotich, J. (2008). Digitally Networked Technology in Kenya's 2007–2008 Post-election Crisis. Berkman Center Research Publication.
- Gordon, Th., Karacapılıdis, N., Voss, H. and Zauke, A. (1997). Computer-mediated cooperative spatial planning, in Timmermans, H. (Ed.), *Decision Support Systems in Urban Planning* (pp. 299–309), E. and F. N. Spon.
- Harris, B., and Batty, M. (1993). Locational models, geographical information and planning support systems. *Journal of Planning Education and Research*, 12, 84-98.
- Hemment, D., and Townsend, A. (2013). *Smart citizens*, FutureEverything Publications.

- Howe J. (2006). The rise of crowdsourcing. *Wired Magazine*.
- ITU (2011). The World in 2011: ICT Facts and Figures, International Telecommunications Union, Geneva. Retrieved July 2014. Available from <http://www.itu.int/ITU-D/ict/facts/2011/material/ICTFactsFigures2011.pdf>
- Kibora, L. (2009). Téléphonie mobile: l'appropriation du SMS par une 'société de l'oralité'. *Mobile Phones: The New Talking Drums of Everyday Africa*, Cameroon/Leiden: Langaa/ASC, 110-24.
- Kieh Jnr, K. G. (2008). *Africa and the Third Millenium*. Asmara: Africa World Press.
- Kreutz C. (2009) Mobile activism in Africa: future trends and software developments, in Ekine, S. (Ed.), *SMS Uprising: Mobile Phone Activism in Africa*. Cape Town: Pambazuka Press.
- Laurini, R. (1998). Groupware for urban planning: an introduction. *Computers, Environment and Urban Systems*, 22(4), 317–333.
- Lee, D. B. (1973, May ). Requiem for Large-Scale Models. *AIP Journal*, 163-77.
- Lee, D. B. (1994). Retrospective on large-scale urban models. *Journal of the American Planning Association*, 60(1), 35–40.
- Marful, A. B. (2014) Smarting the City or Development: The Dilemma of the Post-Oil Countries in sub-Saharan Africa. Paper presented at RealCorp conference, 2014 Published online, in Schrenk M., Popovich V., Zeile P. & Elisei P, *Proceedings REAL CORP 2014 Tagungsband 21-23 May 2014, Vienna, Austria*. Retrieved July, 2014, from [http://www.corp.at/archive/CORP2014\\_136.pdf](http://www.corp.at/archive/CORP2014_136.pdf)
- McGrath, B. (2008). *Digital Modelling for Urban Design*. Wiley Publishing.
- Melis G., Masala E. and Tabasso M. (2015), From the Smart City to the People-Friendly City. Usability of tools and data in urban planning, in Vesco, A., Ferrero F. (Eds.), *Handbook of Research on Social, Economic, and Environmental Sustainability in the Development of Smart Cities*, IGI Global, 361-378
- Moere, A. V., and Hill, D. (2012). Designing for the Situated and Public Visualization of Urban Data. *Journal of Urban Technology*, 19(2), 25-46.
- Murray R., Caulier-Grice J., Mulgan G. (2010) *The Open Book of Social Innovation*, The Young Foundation, NESTA.
- Nyerges, T., and Jankowski, P. (1997). Adaptive structuration theory: a theory of GIS-supported collaborative decision-making. *Geographical Systems*, 4(3), 225–259.
- Odendaal, N. (2003). Information and communication technology and local governance: understanding the difference between cities in developed and emerging economies. *Computers, Environment and Urban Systems*, 27(6), 585-607.
- Okolloh, O. (2009). Ushahidi, or 'testimony': Web 2.0 tools for crowdsourcing crisis information. *Participatory learning and action*, 59(1), 65-70.
- Periphèria Project (2013), Policy Document. White Paper: Human Smart Cities. Revision: [V 3.0], 18.05.2013. Retrieved July 2014. Available from <http://www.periphèria.eu/library/periphèria-policy-document>
- Read, S., and Pinilla, C. (2006). *Visualizing the Invisible: Towards an Urban Space* vol. 1 Purdue University Press.
- Seltzer, E., and Mahmoudi, D. (2013). Citizen participation, open innovation, and crowdsourcing challenges and opportunities for planning. *Journal of Planning Literature*, 28(1), 3-18.
- Sieber, R. (2000). GIS implementation in the grassroots. *URISA Journal*, 12, 15–29.
- te Brömmelstroet, M. C. (2010). Equip the warrior instead of manning the equipment: Land use and transport planning support in the Netherlands. *Journal of Transport and Land Use*, 3, 25-41.
- Tiwari, A., and Jain, D. K. (2013, December). 3D City Model Enabled E-Governance For Sustainable Urbanization. In 14th Esri India User Conference id: UCP0024 (pp. 11-12).
- Townsend, A. M. (2013). *Smart cities: Big data, civic hackers, and the quest for a new utopia*. WW Norton & Company.
- UN-Habitat (2012). *State of the World's Cities 2012/2013: Prosperity of Cities*, Nairobi.
- Uran, O., and Janssen, R. (2003). Why are spatial decision support systems not used? Some experiences from the Netherlands. *Computers, Environment and Urban Systems*, 27, 511-526.
- Vaccari, A., Calabrese, F., Liu, B., & Ratti, C. (2009, November). Towards the SocioScope: an information system for the study of social dynamics through digital traces. In *Proceedings of the 17th ACM SIGSPATIAL International Conference on Advances in Geographic Information Systems* (pp. 52-61). ACM.
- Vonk, G. (2006). *Improving planning support; the use of planning support systems for spatial planning*. Utrecht: Nederlandse Geografische Studies.
- Wesolowski A., and Eagle N. (2010), Parameterizing the Dynamics of Slums, AAAI Spring Symposium 2010 on Artificial Intelligence for Development (AI-D). Retrieved July 2014. Available from <http://ai-d.org/pdfs/Wesolowski.pdf>



## Gestão UrbanaSP:

# The City Built on a Network Society

- ◉ Weber Sutti
- ◉ Marcus Vinicius Russo Roberto
- ◉ Anita Gea Martinez Stefani
- ◉ Esther Madeleine Leblanc

São Paulo City Hall, São Paulo, Brazil

### Abstract

The beginning of Fernando Haddad's administration was characterized by the creation of a new regulatory framework for the city, obtained from the revision of the Strategic Master Plan. To embrace society within this revision, the government opened this process by which traditional participatory methods (public hearings) coexisted with innovative ones (digital platforms) in order to involve the maximum number

of citizens, representing economic, social and cultural interests, and to attend to expectations of a social and modern participation. Therefore, a digital platform called Gestão UrbanaSP (<http://gestaourbana.prefeitura.sp.gov.br>) was created to engage and optimize social participation in the process. Successfully, this platform was an example of transparency and accountability in a way that inspired other programmes to follow this path.

### Keywords:

Urban Management, Master Plan, Open Government, Social Participation, Transparency, Open Source.



## Introduction: Government openness through digital platform

This paper aims to show that a new kind of government openness and social participation was introduced in São Paulo's current administration, which broke new ground with an innovative platform of interaction used to assist in the formulation of a new regulatory framework for the city. Led by the mayor, Fernando Haddad, and the secretary of urban development, Fernando de Mello Franco, the revolutionary platform was named *Gestão Urbana SP* (Sao Paulo's Urban Management).

By analysing Brazil's background, beginning with its transition to democracy after a 20-year dictatorship, this paper will show how public demands were transformed after this first moment of openness; how the nature of social participation evolved after this opening in 1988; and how the current administration enhanced this process in the twenty-first century with new platforms of democracy and interaction.

Therefore, we will show how the administration worked in its first 100 days of the government's digital service that included a free software platform, apps and social media, all to embrace city residents in territorial decisions, especially on that which concerns the city's Strategic Master Plan.

## Brazil: Its democracy and Digital Transformation

At the end of the twentieth century, Brazil was in the midst of great social engagement due to its embrace of democracy. At the time, in the mid-1980s, Brazilian society understood that it could influence the State's decision and policymaking by horizontal interaction, different from that of the dictatorship period.

Within this scenario, Brazilians fought to join the decision-making processes in a new kind of government: one that was accountable. People applied media social and popular pressure to achieve this, which culminated in the creation of the 1988 constitution, which guaranteed such public expression.

In addition to the political struggle, social movements and other instruments endorsed the transition to democracy; like the advent of Internet as well as information and communication technologies. The ICTs provided, through hardware, software and telecommunications processes, scientific research and business learning. The Internet enabled the information to be more accessible to citizens and reach a digital environment that would permit administrations and society to bond in an innovative way. When this happened, society felt eager to contribute and find out how it could be a part of the policymaking process. This enthusiasm began to increase among young people. The interaction between them through blogs and other social media platforms showed that the moment permitted an exchange of information and discussions of several themes. One of the themes was the cyber activism itself. Therefore, some people think that these instruments changed the way of making and seeing public policies, since it gave greater transparency and possibility of accountability between State and society. ICTs and the Internet would be instruments which consolidated the representative

democracy because it helped question how to implement this model of government, assist the structure and thereby make it successful. In that way, citizens constituted part of the process, supervising and participating through collaborative work and discussions.

Due to this entire process and information revolution, Brazil upgraded its digital way of thinking. The country realized that it needed to invest in initiatives of virtual and collective development, such as the e-democracy website of the House of Representatives and the Observatory of Youth Participation. At other levels, digital initiatives are being utilized to carry participatory budget tools and other portals like São Paulo's *Gestão Urbana SP*, which will be described in the third point of this paper. Before that, however, this document will contextualize the desire for change in Paulistan society and the situation in which the city administration and its mayor embraced this project.

## Haddad's Election

As the worker's party candidate for mayor of São Paulo, Fernando Haddad was known for strong campaign for the expansion of public housing and democratic participation of several groups through better urban development.

He wanted to change the city's scope, and was the face of a modern politician with a renewed perspective on running the city. This earned him the support of well-connected groups like art and digital culture collectives, which are known for demanding this kind of new policymaking and the use of the Internet for mobilizing and organizing the public.

Haddad won the elections in 2012, with 55.57 per cent of the votes, and started the process. His slim victory, however, initially made it difficult for him to govern. A project that at first seemed like it stood little chance of being implemented started to become reality. Haddad was prompted to say he wanted to open up the city, democratizing the way in which decisions are made about its development. Thus, his supporters during the campaign embraced this premise and, for that matter, a lot of young representatives joined in the management of the city. However, it was inside the Urban Development Secretariat - in charge of revision of the city's Strategic Master Plan - that the digital footprint blossomed.

## How to manage an Information Revolution?

"The communicating and information-processing power of the Internet is being distributed in all realms of social life" (p. 24), Manuel Castells says in his book *The Rise of Network Society* (2010). The information revolution opened the path to activism for civil society. This new interconnection and accessibility to different data, news media and research endorsed a desire to participate in local and global areas. Therefore, similar volitions and ideas began to team up in a process that highlighted specific desires, facilitating something that could be noticed in minor local groups like neighbourhood associations or low-level but specific kinds of militancy.

When this information processing expands to every societal layer, affecting lifestyles and even their organizational structuring, it becomes

part of the administration's worries. The task before the administration becomes: how make an interconnected civil society part of the municipal processes?

This question is an issue for governors and administrators. It pervades the municipal and federal power structure, including decision-making processes and groups such as labour unions, and even small communities. The avenue for participation, opened by the information revolution, aroused the people's will to participate and municipal administrations are duty bound to accommodate this societal demand.

We are witnessing a new chapter in history; a new kind of government openness. As part of this process, São Paulo's administration is modernizing, albeit confronted with challenges. To complement this resolve and post-modern process, governments must be rejuvenated and always willing to open its platforms, as well as stimulate communication between all social and political levels.

## How Haddad Responded to the Information Revolution

With this challenge in sight, Haddad's administration, in its first 100 days, worked very hard to introduce the revision of the Strategic Master Plan and define a new regulatory framework for the city with the best participation of society. The previous administration tried to do it in 2006 but failed mainly due to the lack of society's participation.

So, the Haddad administration took up the task to change the urban scope in an effort to minimize social and spatial differences, thereby transforming São Paulo into a more democratic city with equal opportunities and a good quality of life for all its residents.

Thus, the city's Urban Development Secretariat prepared a plan for five interventions. These aimed to rescue residents living in unsafe areas by stimulating political participation and improving the public services; by optimizing the city's development, integrating environmental resources with existing framework; by enforcing better development of neighbourhood core areas; by redevelopment of the city centre; and by realignment of environmental borders.

Despite the support of urban groups and the youth, Haddad's task was difficult in that he had to struggle to win public goodwill. Therefore, one of the ideas to optimize the project and establish the new Strategic Master Plan involved an innovative instrument of electronic participation in São Paulo's government. This instrument was a digital platform that sought to inform and increase public involvement in the urban and territorial change being proposed by the administration, called *Gestão UrbanaSP*.

This platform stamped a digital footprint within City Hall, since it worked as a permanent headquarters to discuss the Strategic Master Plan. Therefore, to stimulate public participation in it, the administration thought of a new form of policymaking, which encouraged civil society to be a part of this agenda through this digital platform.

Aligning traditional participatory methods, like public hearings with innovative methods, such as public meetings with hackers, this new platform was created, in April 2013. Its purpose was to engage this networked society that was eager to be part of this new concept in policymaking. The administration established a hybrid model of participation, since the platform was also being debated at face-to-face events in town subdistricts. Therefore, a new form for inclusion was being used for discussions, since City Hall was hosting physical events and feeding a digital platform with the content.

The first attempt at utilizing these innovative methods began with the "Café Hacker", a pioneer and public event that prioritized an informal dynamic as a way of giving feedback and proposals that would continue the development of *Gestão UrbanaSP*. The event helped nourish the platform and was so well accepted by the administration that it was incorporated by the municipality's general comptroller with its own website: <http://cafehacker.prefeitura.sp.gov.br>.

After its launch and contributions, *Gestão UrbanaSP* started to systematize all the information about the Strategic Master Plan by presenting data (more than 4GB of open data), documents, laws, news and live streaming activities through four stages, explained and posted to the website <http://gestaourbana.prefeitura.sp.gov.br/>, which is hosted in an open software platform.

## Gestão UrbanaSP's stages

This digital platform was created as free software, which is very important to the openness issue. This kind of software can be expanded with existing free applications. Besides, it can receive partnerships and be reused. Citizens acting as code developers, designers and hackers can contribute to the software because it is open, free of charge and unrestricted, unlike privately-owned material. *Gestão UrbanaSP* was designed to work through four phases. The first was based on a social networking approach, seen as the best way with which to start communication between city authorities and the public. For that matter, the platform was spread through a Facebook page and email marketing, *Gestão UrbanaSP*'s main elements. When this communication was established, the platform started to work as a digital headquarters of the Strategic Master Plan.

The second phase aimed to obtain propositions and contributions from the public through face-to-face workshops held in all 31 subdistricts. This process was also released on the Internet with an online live streaming tool hosted on the *Gestão UrbanaSP* website. There were 2,727 propositions collected on the *Gestão UrbanaSP* platform through two open and easy to understand channels: an online form and crowdsourced mapping (available from <http://mapa.gestaourbana.prefeitura.sp.gov.br>). These channels enabled people to get access to suggestions in a more interesting and visual way. The mapping technology, also an open software instrument, was developed in a hacker's laboratory and adopted by the city administration. The result can be seen in the following map image:

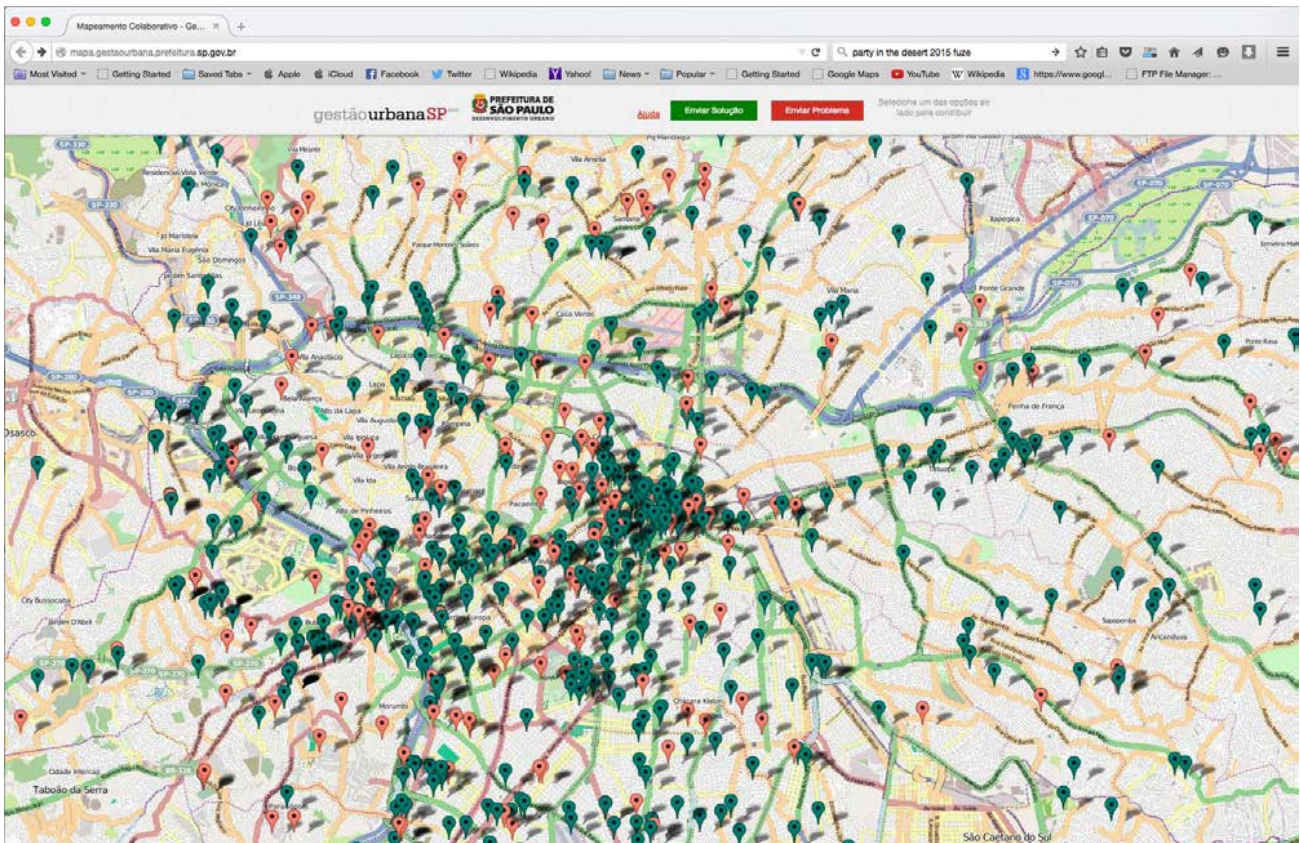

Screenshot from the crowdsourced mapping tool. In: <http://mapa.gestaurbana.prefeitura.sp.gov.br/>

The third phase reunited the collaborations and propositions in one digital report (<http://gestaurbana.prefeitura.sp.gov.br/relatorio>), available online to the public, and serving as an instrument of accountability and systematization. These three phases culminated in the fourth and last stage of the process, the online Strategic Master Plan draft (<http://minuta.gestaurbana.prefeitura.sp.gov.br>), an open software tool also incorporated by the administration. The tool enabled the public to compare the draft with the current law and propose changes to the bill.



SOLVING URBAN PROBLEMS NOW REQUIRES TAKING INTO ACCOUNT THE CULTURAL, ENVIRONMENTAL, LEGAL, OR SOCIETAL REALITY SURROUNDING A SPECIFIC PLACE IN WHICH THE SUBJECTIVE EXPERIENCE AND OPINIONS OF CITIZENS ARE BECOMING AS IMPORTANT AS THE PHYSICAL MANIFESTATION OF BUILDINGS AND PUBLIC SERVICES IN THE URBAN LANDSCAPE.



In total, 1,822 contributions were made to the draft from workshops and through Internet interventions thus demonstrating the success of this hybrid model of participation.

This unique process of policymaking in São Paulo created unprecedented advantages, new forms of participation, accountability and democratic inclusion. The praxis of open technologies and agile methodologies provided a fast and low-cost process. Additionally, it was a fundamental instrument to show that the Strategic Master Plan revision was counting on civil society's mobility, something questioned by non-governmental associations that were probably little acquainted with the whole process. An association even tried to prevent the SMP's legalization, saying its formulation was closed to public scrutiny. However, this view was not substantiated and was, therefore, unconvincing. Actually, the GestãoUrbanaSP platform and all its information and the data collected showed that society embraced the process in its online and physically forms. For example, the system recorded 1.8 million online views through electronic channels between April and September 2013, and 19,265 participants at public events during the same period.

Through closer analyses, the conclusion is that a great part of digital collaboration was performed by Lapa and Santo Amaro, both wealthy neighbourhoods of São Paulo. This is illustrated in the report screenshot in the next page.



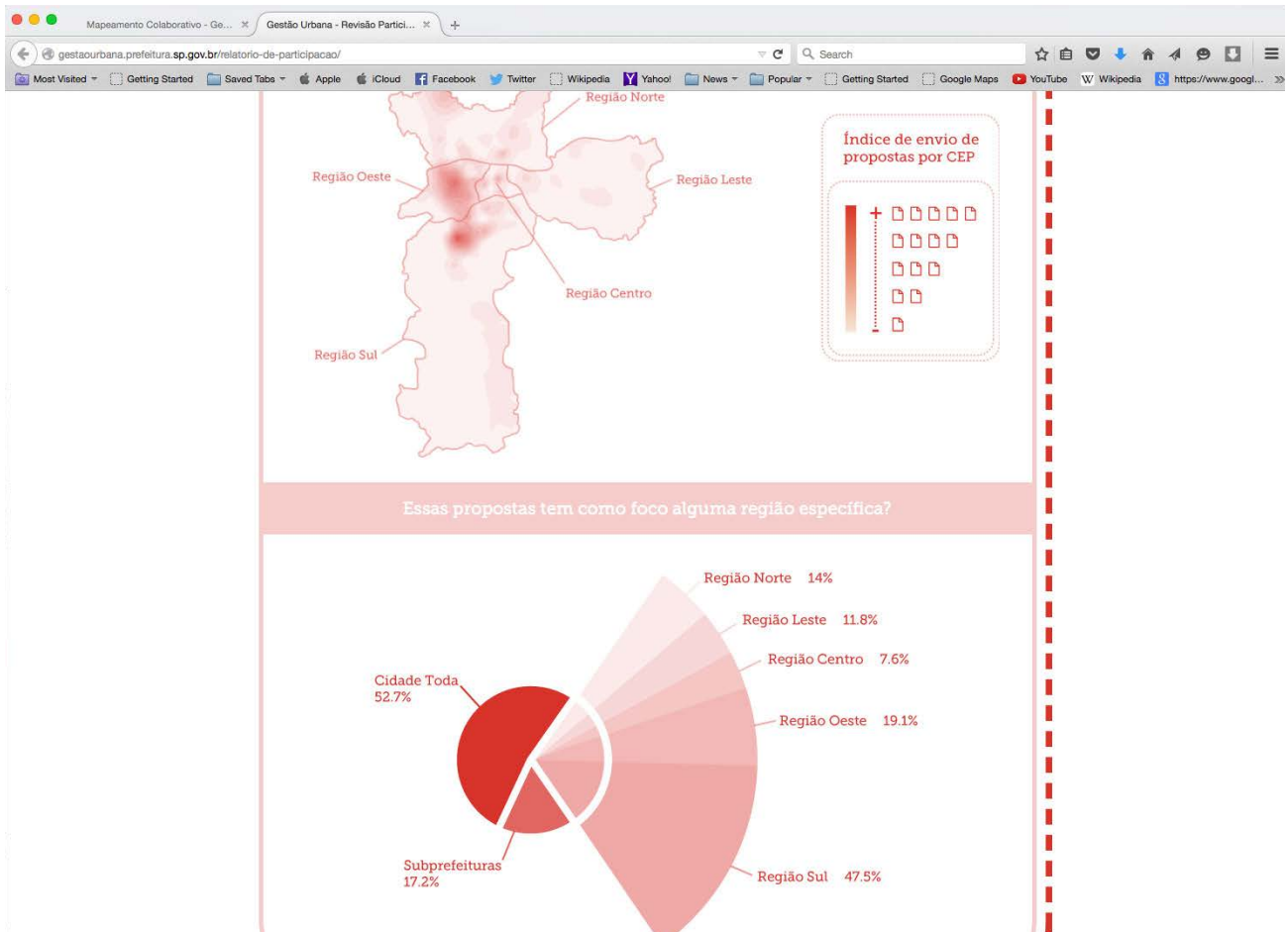

Screenshot from collaboration mapping: above, the darker red spots indicate the neighbourhoods of Lapa and Santo Amaro, representing more collaborators through the GestãoUrbana platform. In: <http://gestaourbana.prefeitura.sp.gov.br/relatorio-de-participacao/>

Besides being wealthy regions, Santo Amaro and Lapa probably collaborated more within the platform due to their inhabitant's profile. These neighbourhoods are populated with a lot of teachers, technicians and liberal professionals who are more interested in the city's public policies and configuration and, therefore, aim to participate in shaping its bye-laws and guidelines.

Although Lapa and Santo Amaro participated more within the online process, other neighbourhoods without a proper online connection and Internet engagement also collaborated in their own offline way. Less wealthy parts of the city such as Heliópolis and Freguesia do Ó contributed a lot to the Strategic Master Plan constitution. This occurred through public hearings, mainly because their residents were mobilized by community leaders to attend and thus discuss their interests in the city's policies.

In sum, we can say with certainty that the Strategic Master Plan was created with a whole new engagement from civil society and from representatives of several sectors of the city. Their propositions were submitted in an easy and open way, which started and permitted the participation of the entire city in São Paulo's SPM revision process.

This new set of information permitted the administration's Urban Development Secretariat, through its departments, to develop the draft Strategic Master Plan bill. Published on the web, the draft was also accessible on the GestãoUrbana platform for civil society through an exploratory interface: <http://minuta.gestaourbana.prefeitura.sp.gov.br/>.

Suggestions and interactions made by the public were inserted into the draft SMP bill, which could be accessed through the website <http://minuta.gestaourbana.prefeitura.sp.gov.br>

### How GestãoUrbanasp provided knowledge to further projects

Based on these great results that GestãoUrbanaSP gave to the administration and to the Strategic Master Plan's formulation, the central government is already expanding the experience to other levels of the municipal administration. Additionally, the Urban Development Secretariat realized it needed to keep upgrading itself technologically in order to better handle these processes in such a way that the administration would be able to institutionalize the Digital Core Team responsible for this revolutionary change. To better develop other projects, it would be essential for public administrations to keep

supporting these digital performances, as well as to keep investing in traditional communication such as radio, television, and newspapers in order to involve and mobilize the whole population in forming public policies and resolutions. Moreover, public administrations (of city and central government) should promote activities where they occur in order to better serve public demands. Once interviewing city residents and studying their requests, city administrations can improve, for instance, their digital platforms, thereby enabling an accurate instrument consistent with the public interest. This kind of policy between online and offline structures will align society's demands.

This whole process is catalysing the São Paulo administration's openness, spreading free software in the administration along with the creation of an Intersecretarial Committee for the Open Government movement. The public vehicle of this committee is the São Paulo Aberta (<http://saopauloaberta.prefeitura.sp.gov.br/>) – meaning Open São Paulo - initiative, which is a programme that seeks to embrace society into public policy discussion through electronic channels and activities “on the ground” within a partner network that supports, collaborates and shares City Hall's actions and policies.

Furthermore, the Café Hacker's project already mentioned is a product of this digital achievement. Created to attend to GestãoUrbanaSP's needs, the Municipal General Comptroller appropriated the project, which also has a structured website that brings together public data opened to discussion. The project encourages regular meetings between journalists, web developers; and researchers interested in data that involves the city's administration; and technicians or representatives aware of these procedures and information. These technicians and representatives generally deal with a large amount of data but may be unaware of public demands and needs for such information. The last inquiry Café Hacker conducted concerned transparency in the way the city government handled investment regarding the 2014 World Cup football tournament.

The GestãoUrbanaSP philosophy is encouraging other city administrations to embrace the same digitalization process. With this new way of thinking public policies and the means by which to reach the public openly, the Programa de Metas website (meaning the Administration's Programme) (<http://metas.prefeitura.sp.gov.br/>) - shows the administration's performance in projects and budgets reports. Thus access to such open data enables the public to form a sharper picture of the city government's actions. In this way, the GestãoUrbanaSP platform may have triggered a new paradigm of accountability, transparency and openness.

## Conclusion - A positive reaction to Gestãourbana's platform

To perpetuate this digital culture that stimulates transparency and openness for good, whether in this government or future ones, the Haddad administration is developing and institutionalizing the “Digital Core” in order to invest even more in the open source, free software, social media, crowdsourcing and open data stimulated by this process.

The lessons are that the public and social movements reacted positively to the change, since the accesses were beneficial to the process and to society. The administration learned that the political agenda must incorporate transparency, openness and participation within the dynamics of a network society. In addition, the administration discovered that the agenda must also incorporated constitutional rights such as public access to information.

As Pierre Lévy would say, we are experiencing a time of collaborative learning and knowledge that reverberates into a new kind of political identity. This identity is based on production, consumption and data processing in communication networks. This experience is a basic structure of “cyber democracy” and, therefore, society's expanded participation in decision-making processes.

“Technology and technical relations of productions diffuse across every set of relations and social structures, permeating power and experience, changing them,” (Castells, 2010, p. 32). For that matter, the information revolution changed the paradigm; we no longer live in a vertical structure where the State “reigns” over society. Now, we are experiencing a horizontal arrangement of interaction, where society wants to be a part of the State and engineer its transformation by participating in the making of public policy. This makes sense when one examines the percentage of Internet access around the world: developed countries have on average 71 per cent of their population connected. In developing countries, this is about 21 per cent (according to <http://www.cetic.br/>). In Brazil, 102.3 million people are connected, according to the Index from Ibope Media. This is half the population – but may not look so impressive when compared with developed countries, but is very expressive to Brazil's reality.

The good news is that this percentage will continue to grow, and with it social participation in public policymaking. Therefore, it is reasonable to say that we are witnessing a true revolution regarding social participation in São Paulo's government, and that the GestãoUrbanaSP platform was our first evidence of its success.

## References

### Authored book:

Castel, Manuel (2010). *The Rise of Network Society*. Wiley Blackwell.

Conargo, Noé (2005). *Democracia y nuevas tecnologías: límites del enfoque tecnocrático para la comprensión de los problemas de la democracia representativa*. Mediatika.

Diniz, Eli (1997). *Crise, reforma do Estado e governabilidade: Brasil 1985-1995*. Rio de Janeiro: Ed.: Fundação Getúlio Vargas.

Fountain, Jane (2005). *Questões Centrais no Desenvolvimento Político do Estado Virtual*. In Castells, Manuel (org). *A Sociedade em Rede. Do Conhecimento à Acção Política*. Imprensa Nacional - Casa da Moeda. Lisboa, 2005. p. 149-175.

Levy, Pierre (2010). *Cibercultura*. Editora 34.

Stefani, Anita G. M. (in press) *Utilização de TICs em processos participativos no Brasil sob a ótica de capacidades de governo*. São Paulo. (Prevision Screen – June/2015)

### Web site:

<http://www.cetic.br/>

<http://www.ibope.com.br/pt-br/>

<http://g1.globo.com/sao-paulo/eleicoes/2012/noticia/2012/10/fernando-haddad-do-pt-e-eleito-prefeito-de-sao-paulo.html>

<http://www.webaula.com.br/index.php/pt/acontece/noticias/2874-pierre-levy-fala-dos-beneficios-das-ferramentas-virtuais-para-a-educacao>

<http://gestaourbana.prefeitura.sp.gov.br/>

<http://cafehacker.org/>

<http://mapa.gestaourbana.prefeitura.sp.gov.br/>







# Façade Improvement through Public Participation

## in South Salsabil District of Tehran

- Sarah Ferdowsi  
ReUrbs Laboratory, Tehran, Iran
- Elgar Kamjoo  
ReUrbs Laboratory, Tehran, Iran
- Mina Amani  
ReUrbs Laboratory, Tehran, Iran

### Abstract ○

Tehran is the capital city of the Islamic Republic of Iran. Over the past several decades, the city has grown into a megacity of 10 million inhabitants causing a huge demand for new houses and commercial spaces. The increasing demand has resulted in a corresponding construction market that has grown without much care about the aesthetic, environmental and cultural requirements due to inadequate planning and control.

The market driven shapes and material composition of building façades has resulted in a visual demonstration of greatly diverse and non-harmonized shapes and forms. Lack of public views is obvious. This research has tried to pilot how public participation can be engaged through the electronic means of communication for bringing taste and harmony to building façades in Tehran.

### Keyword:

Tehran, façade, public participation

## Introduction

There is no controversy about the importance of aesthetic dimension of urban views and its impact on welfare of inhabitants. Sight pollution, optic pollution, lack of harmony in building frontages and sidewalks inflict adverse impact on the mental and physical health of citizens. Moreover, beautification projects are known to be an important player in economic rehabilitation of neighbourhoods. In astatically sound and dynamic urban environments crime, unruly behaviour and other kinds of social disorder are low and the opportunities for individual and social growth emerge remarkably.

The stability of covering materials is another factor in safety and durability of buildings. A sustainable façade is the result of taking into consideration factors like climate, environment, energy consumption, appropriate use of daylight, proper choice of material and colouring. Notwithstanding the efforts and the progresses made, the earthquake proneness and climate conditions have not been adequately considered as determining factors in the architectural design and construction of buildings in Tehran. Unprofessional and inconsiderate use of glass, composite material and stone are obvious manifestations of unsustainable construction work in the city. A new guideline issued by Tehran Municipality limits the use of glass to 40 per cent of the surface area of a building façade (Tehran Municipality, 2014). The horizontal building line; the harmony of the building façades with that of adjacent buildings, and with the street and the rest of the neighbourhood; the role of trees and green spaces around buildings; the form and accessibility of main entrances and parking lots; and the needs of the disabled and the elderly are among the factors influencing the beauty and sustainability of cities, and the quality of lives of residents.

The ReUrbs Laboratory was founded in 2013 as a non-governmental organization by a small, but multidisciplinary team of young professionals with expertise in architecture and urban design, dedicated to research the underlying causes of the urban problems in Tehran, and subsequent attempts to solve those problems.

We believe that the best way to address the urban development obstacles is to take a participatory approach that provides for stronger attention to marginalized populations of the country.

The first professional project of the team was defined in 2013 on façade improvement in Tehran.

## Evolution of Tehran into a megacity and its current texture

Tehran is the capital city of the Islamic Republic of Iran, a megalopolis with some 10 million inhabitants that is the country's the largest administrative and commercial hub.

In 1788 Tehran, then a rather small enclave, was declared as the country's capital city mainly because of its geostrategic location.

Over time, the city had to gradually open the doors to the changes caused by the introduction of industries and the new business systems

such as commercial banks. Accordingly, the city had to grow beyond its walls particularly northward. The city was then governed, in all its aspects, by military generals appointed by the King.

The 1906 Constitutional Revolution brought a strong wave of demands for the rule of law. In the aftermath of the this revolution, the First Municipal Act of 1907 required cities to be to be run by a municipal authority under the control of a "council" of elected representatives (Mozayeni, 1995).

The revolution could be considered as the result of an unseen but intrinsic conflict between urban and rural populations, the latter having always been the main supporter of dictator monarchies under local ruling of tribal leaders.

For the first time the urban areas, and particularly the capital, became the centre of public protests and revolutionary activities.

New urban features like squares, plazas, broad streets and city parks emerged based on the European models; the traditional building façades were altered to resemble the western style. By the beginning of the second half of the twentieth century, Tehran was already a rather large city with many of the elements characteristic of an urban region (Kiani, 2002). The approval of the city's first urban plan in 1970 further stimulated this process of change.

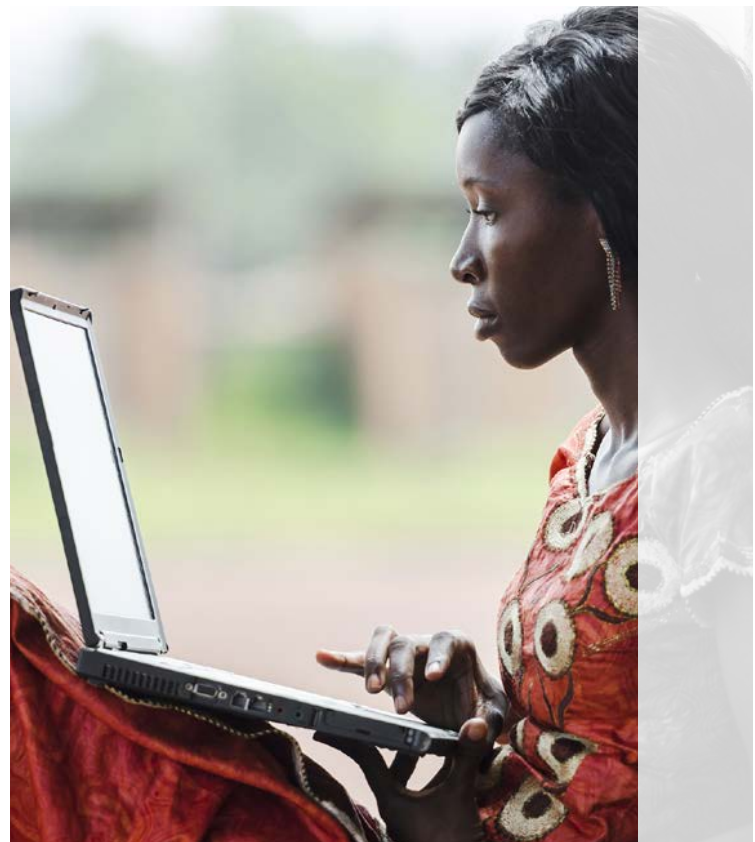

**Education for Africa: Technology Symbol African Woman Studying Learning Lesson.** © Shutterstock/Riccardo Mayer

Following the 1979 Islamic Revolution, the notion of participatory councils gained stronger ground, but based on religious concepts. The government opted for a complete set of Islamic councils at all levels - from villages and rural districts, to towns, cities, counties and provinces. However, the councils remained mostly non-functional until 1998 (Mohammadi, 2010).

The first "Tehran Comprehensive Plan" of 1970 provided for expansion of the city towards its western suburbs. The post-revolution Comprehensive Plans of 1991 and 2006 tried to limit the city's rapid expansion, but in vein. The failure was caused by a series of factors, amongst them the heavy concentration of administrative and economic institutions, and job opportunities in the city.

Tehran's population grew dramatically due to the migration of rural folk and people from other cities in the last two decades. Therefore, the city's boundaries were expanded, attracting even more people.

The corresponding demand for urban services has been huge, particularly for additional housing. The need for new houses created a significantly vast and highly competitive market demonstrated by the rapid growth in the number of housing agencies. According to official statistics, the real estate sector constituted 5 per cent of the gross domestic product in 2008. The process of building construction has outpaced, by far, the legislation development processes. This competition, which in many of the city's residential areas is running in a multi-neighbourhood scale, has resulted in the creation and introduction of bizarre building shapes and styles. Each constructor applies its own taste and preferences derived by the intention to maximize the marketability of the newly built apartments through cutting (sometimes the essential) costs and introducing eye-catching building façades. More often than not, this results in buildings that are environmentally unfit, non-user-friendly, unsafe and strange looking. The reasons behind this undesirable situation can be summarized as the highly profit-minded, competitive and unprofessional construction market; frequent changes in rules and regulation; urban governance issues and inability to adopt new methods (e-governance, for instance); frequent changes of managers; and inadequate public knowledge and awareness vis-à-vis environmental, cultural and artistic aspects of urban areas, and lack of their participation. Moreover, the relatively low price of manpower in the construction sector contributes to the rapid reconstruction. There are cases where a building has been reconstructed twice just to apply a new style. Building durability does not seem to be given much attention.

In this project we have tried to challenge the current construction tradition and behaviour by raising public awareness and mobilizing public participation in decision-making.

## Tiers of Urban Governance

Urban governance is carried out at three levels: national, provincial and municipal. At the national level are ministries, organizations, institutions and national councils whose jurisdiction is countrywide. At provincial, the governorate general in each province represents the Ministry of Interior and coordinates the work of the provincial representation of national institutions and councils.

The Islamic City Council of Tehran oversees the urban management implemented by the municipality. The municipal level of urban management is in direct relation with citizens. Figure 1 below shows the various tiers of urban governance in Tehran.

Figure 1. Municipal Management Chart

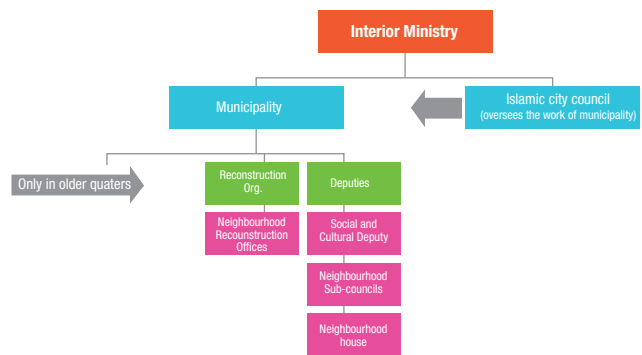

The Ministry of Interior is mandated to appoint mayors in cities with a population greater than 200,000; endorse structural changes in municipalities; approve urban plans; and oversee the election of city councils and mayors. Therefore, the ministry is indirectly involved in municipal urban management.

## :: Municipalities

Tehran Municipality was established in 1907. In 1930, the Municipal Law was replaced by a new enactment according to which municipalities became fully dependent to the state system. In 1952, the law was once again revisited to increase the role of city councils. In the following years, the Law of Urban Renewal and Development was approved and the High Council of Urban Development and Architecture was established.

Municipalities are non-governmental, independent public institutions fulfilling a whole range of responsibilities including oversight and protection, welfare, urban development, and resource management. The municipality is supervised by the mayor. Tehran Municipality has 15 deputies including one for cultural and social affairs, who is responsible

**Table 1** Tehran Population 1956-2006

YEAR	1956	1966	1976	1986	1996	2006
Population	1 560 000	2 719 000	4 530 000	6 042 000	6 759 000	7 798 000

for providing support to two major public participation-related cells; that is the neighbourhood sub-councils and neighbourhood houses.

### :: City Councils

In March 1998, the first round of nationwide elections of city councils was held. These councils are elected for a four-year term and are responsible for selection of mayors; planning for public participation in social, economic, constructional, cultural, educational issues; and others related to welfare of citizens. The council monitors and oversees the municipality's income and expenditures and reports to the public on issues related to the municipality.

### :: Neighbourhood Sub-councils

These are non-governmental, decentralized, non-political, voluntary-based and participatory, self-managing associations at neighbourhood level. The sub-councils are public representatives to ensure better management of their neighbourhood and act as a channel of communication between the public and municipal entities (for example city council, municipality).

The sub-councils aim to be effective representations of citizens at the neighbourhood level. They are to provide a platform for two-way communication between people and authorities to ensure public participatory decision-making and to benefit local knowledge and capacities in each neighbourhood.

### :: Neighbourhood Houses

Neighbourhood Houses have been established in accordance with the law. They are created to accommodate neighbourhood sub-councils and provide a meeting point for residents of each neighbourhood. Neighbourhood Houses provide the infrastructure for citizens in each neighbourhood to work together. They are the institutional support and executive arms of national sub-councils.

### :: Tehran Municipal Reconstruction Organization

According to the law, the municipality can use its own resources to purchase land, old houses and commercial estates and then reconstruct them in accordance with new plans. The Organization is responsible for establishment and administration of the Renewal and Reconstruction Secretariat; participation in the development of the vision, strategy and policies regarding the reconstruction of Tehran; development of a plan for revamping dilapidated areas of the city; identification and mobilization of all stakeholders in city reconstruction; and the development of incentives to advocate for reconstruction of rundown estate by owners.

## Public participation in urban decisions - use of ICT

In recent years different government agencies and municipal authorities involved in urban planning and management have made efforts to accommodate citizen engagement in urban decision-making. Many development projects have been prepared by Tehran Municipality based on public participation and some of them have been supported by international organizations.

The approach has, however, been haphazard in its application. Every now and then the municipalities and city councils make attempts to involve public views in urban issues. Some attempts work, some do not, and some are just abandoned. "Healthy City" and "Better Alley" projects are two examples in the case.

One of the most successful decisions was Tehran City Council's creation in 2008 of a headquarters for overseeing the activities of non-governmental organizations. This office has organized NGO's in 18 different commissions such as those of the environment, women, education, and post-disaster operations. The level of engagement of NGOs (abbreviated as SAMAN in Farsi) has been remarkably enhanced with the help of the headquarters. The same approach has been adopted in other cities. Consequently, there are now at least 15,000 NGOs active in the country and the notion of "being an NGO member" is widespread among educated citizens.

The first e-governance action plan of 2002 called for (1) automation of administrative procedures (office procedures, paperless environment, human resource management, financial systems, for example); (2) application of information technology to re-engineer agency-specific procedures; (3) all government agencies to create their own websites; (4) creation of portals to ensure citizen's access to electronic information; and (5) provision of required training to government employees. The first e-governance exhibition was held in December 2003 (Ashrafologhalei).

In 2003, Parliament allocated a budget equivalent to USD100 million for development of information and communications technology infrastructure in the public administrative sector. The programme included a number of projects in the areas of e-government, e-commerce, e-banking, e-learning and e-health (Haghighi et al).

The five thrusts of e-government in Iran are (1) increasing government efficiency and effectiveness; (2) providing convenient access for all; (3) improving public services; (4) using information technology and telecommunications to build new capabilities and capacities; and (5) promoting social welfare, awareness and knowledge in the society" (Rezazadeh).

A survey published in 2011 suggests that although the level of client satisfaction of the delivery, diversity and accessibility of digital information is higher than average, customers are dissatisfied with the capacity and competency of the staff of ICT offices in general (Yaghoubi et al). Electronic banking and municipal services are mentioned as among the most successful e-governance services.





According to the general census of 2006, some 37,949 people live in South Salsabil (59 per cent of them women). The age composition of the neighbourhood shows that the 20-24, 25-29, 30-34 and 35-39 year ranges are the largest age groups. They constitute 10.96 per cent, 11.83 per cent, 9.86 per cent and 9.61 per cent of the total population, respectively. These statistics indicate that South Salsabil's population is quite young. This age benefit is conducive to easier familiarity with the Internet and global networks as well as a having a stronger appetite for participation. The youthfulness of the area's residents is considered as an advantage for the project.

The same census indicates that almost half of South Salsabil's female inhabitants are housewives, who play a prominent role in participation-oriented projects. This can be seen as a potential success factor for the project.

As shown in figure 3, some 47 per cent of the plots of land in the target neighbourhood are less than 100 square metres in area and 81 per cent less than 150 square metres. The smallness of plot size means room for maximum diversity in building façade types and the resulting management challenges.

Figure 3. Map of Land Dimensions for South Salsabil



Additionally, figure 4 indicates the high rate of residential areas in South Salsabil and the relatively low level of urban services available to its inhabitants.

Figure 4. Map of Current Urban Functions in South Salsabil



In conclusion, South Salsabil is one of Tehran's most suitable neighbourhoods for this study because of its location, participation capacity of inhabitants and authorities, demographic factors, development dynamics and its track record of participatory work.

Figure 5. The diversity of building façade in Hashemi Street, one of the main roads of South Salsabil



## Overview of the project design and implementation

Due to the time consuming nature of beautification projects and in view of the need for public participation as a success factor in such plans, this research project has been defined for a relatively long period of time.

Interaction with inhabitants was done through face-to-face interviews conducted by experts, researchers; the distribution printed questionnaires by students in the neighbourhood; as well as use of the Reconstruction and Rehabilitation Office websites. The project's prime aim was to demonstrate the role of public participation in the improvement of the scenic aspects of the city and the possible use of electronic media in such a paradigm shift. Internet facilities are used, as an innovative tool, to update the information about plans and projects and other relevant information.

### Preliminary Phase

In this stage, more than 5,000 photos were taken of different forms and typologies of building façades and textures in various parts of Tehran. More than 20 typologies were identified out of which seven types were recognized as the most popular (see table 7.1). Analysis of the seven revealed that simple the brick façade was the most suitable when consideration was given to durability, reparability, earthquake risk, economy, local availability of material, transportation and handling, ease and noiseless construction, as well as historical identity of Tehran.

In this phase of project implementation, the team had several meetings to decide on the exact project execution approach. Finally, the team realized that the Neighbourhood House should be chosen as the first entry point. The decision was based on the lessons learned by some other non-governmental organizations like Bahamestan and some other well-experienced practitioners in this field of work.

Given the circumstances, it was important to start from a neighbourhood where the project team members had already established personal acquaintance with a municipal official. Salsabil District was thus selected.

After the selection of the pilot neighbourhood project, the team approached Neighbourhood House and held meetings with its members, most of whom were women. Neighbourhood House put the team in contact with the Reconstruction and Rehabilitation Office, with which the team held consultations. The Reconstruction Office is one of the key stakeholders of the project, given its mandate to oversee the rehabilitation of Salsabil's dilapidated areas. Yet this task is in conflict with the vested interest of local construction firms. Interestingly, the Reconstruction Office advised the project team not to mention their link with it when interviewing the representatives of the construction firms. These small firms are well spread across the parts of the neighbourhood and easily reachable by the inhabitants who wish to rebuild their homes.

### First Phase: Data Gathering and Desk Review

An introductory and project briefing meeting was held with the Rehabilitation and Reconstruction Office where the details of the project plan were presented. Once the team was engaged with Reconstruction

Office, the latter accepted that the team could use the Rehabilitation and Reconstruction Office website [www.thrbaft.ir](http://www.thrbaft.ir) until the Salsabil project established its own. Although the dedicated website is not yet fully operational, the team has been able to execute two steps of the plan through the portal. However, challenges in building a dedicated website - such as heavy bureaucratic requirements - remain.

In this step, through using Form 1, information was gathered from inhabitants about the houses in which they lived. The form seeks information such as the façade type of their residences, the history and original façades of buildings, interrelations with adjacent buildings and public spaces. The information was compiled, categorized and underwent statistical analyses. The results were put on the websites along with the expert analyses and opinions. At this stage, 1,000 forms were distributed among Salsabil's 31,000 inhabitants. Interviewees were asked to check the website for the results. They were also asked to encourage their acquaintances and relatives to fill the form electronically on the website.

### Second Phase: Designing

At this stage the experts in the project team, with the aid of external professionals designed plans to improve the rundown appearances along the main streets of the neighbourhood. The designs were made public on the website with space for comments and questions. Various façades types and construction materials are being designed and put on the website for inhabitants and constructors to choose. This process will be a dynamic and rolling practice as new ideas, designs and construction information emerge and are posted to the website.

### Third Phase: Receiving and documenting Feedback, Awareness-raising

This phase of the project is divided into subphases. In the first, the feedback provided by inhabitants will be considered and factored into the refinement of the designs. This is to be followed by a subphase of public awareness with a focus on target groups like women and students. To this end, project staff accompany experts from the Reconstruction Office on their visits to schools, mosques and other public places to present specific training materials prepared for this purpose. Additionally, the finalized designs will be exhibited in certain public exhibitions.

### Forth Phase: Monitoring and Evaluation

In time intervals of 1, 3 and 6 years from the completion of the third phase, the impact of the project on the shape of new buildings will be monitored through field visits and expert tests. The results, successes, shortcomings and lessons learned will be made public through the Neighbourhood House website.

## Results

The preliminary studies carried out under this project show that there are more than 20 façade typologies in Tehran in terms of the design, material, colour and other factors, out of which seven types have been identified as the most prevalent.

Among the seven most prominent types, the so-called "Roman" façade has been the most popular in Tehran's housing market. This type is

Figure 6. The Screenshot from the RRO Website (Link to the First Project Form Highlighted in Red)

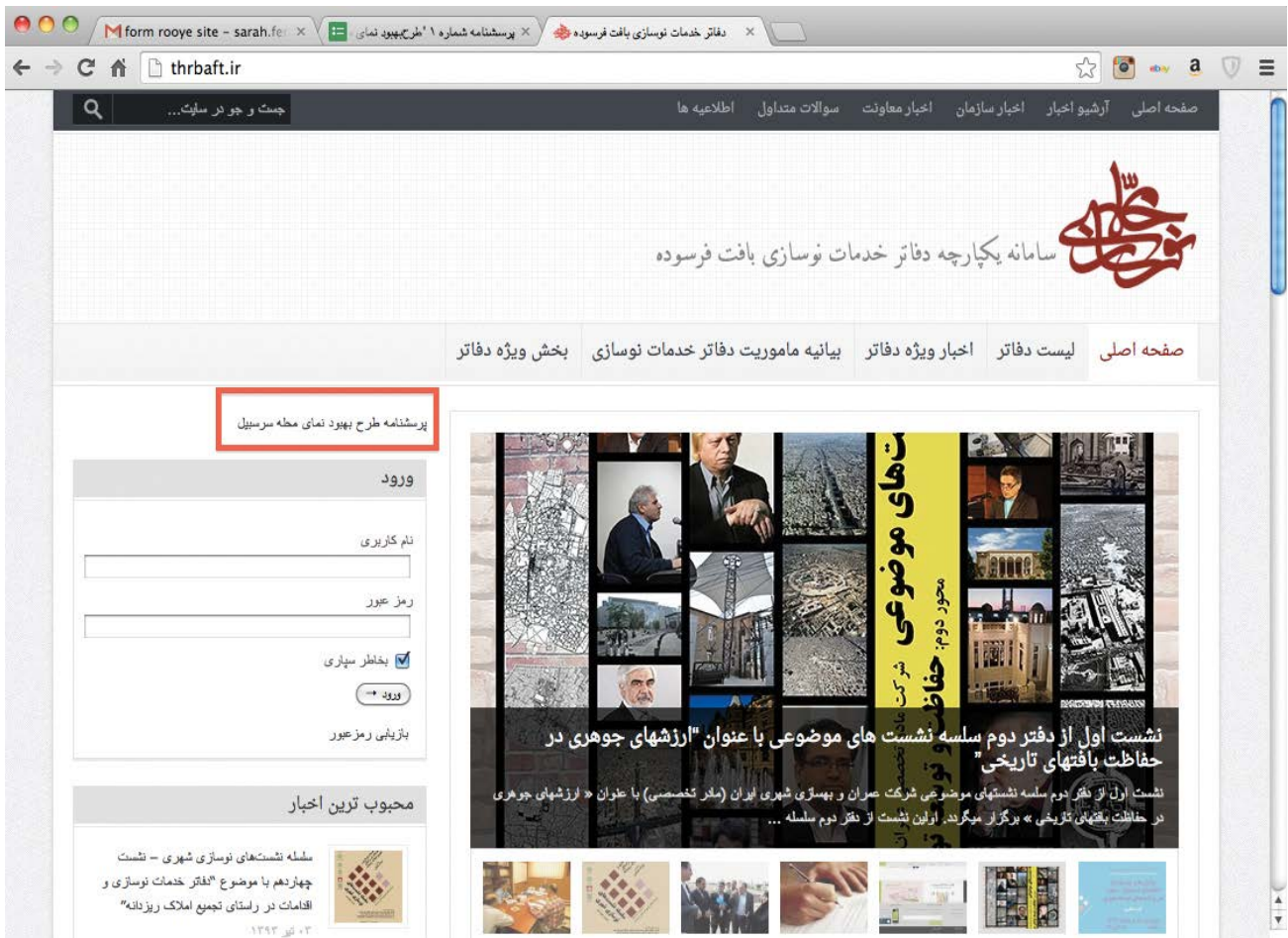

normally constructed with heavy pieces of expensive decorative stone and combines an imitation of some western architectural elements with Arabic ornaments around window frames. The appearance of this style has no formative and environmental harmony with Tehran's realities and requirements. The large pieces of stone are loosely connected to the main walls of the building, most of the time without any fixing structure. In a quake-prone area like Tehran, this is a public danger in the making.

In the first phase of the project it was decided that 1,500 copies (with a deviation of 1 per cent) of the questionnaire would be distributed: 1,000 hardcopies and 500 electronic.

The number of copies was selected in a way that in the extreme event that none of the interviewees are able to respond electronically, the standard deviation would be 5 per cent, which is still acceptable.

In the one month data gathering stage, an additional 127 people completed the form online. This was lower than the expected rate of electronic responses. The results of questionnaire analysis have been

summarized in table 7.2. It is premature to interpret the low level of response through the Internet as an indication of the lack of interest or capacity on the part of inhabitants to work with electronic media. Some limiting factors like the lack of adequate knowledge about the project and its Internet interface may have been involved.

The Neighbourhood Council was highly supportive to allow access to the website and declare the team's readiness to cooperate. However, the sophisticated bureaucracy and some other factors like staff turnover have acted counterproductively.

In addition, the level of field participation in this research was very good and interviewees highly cooperative; there were only a few cases where people failed to show adequate interest in the subject. In some cases, people were very appreciative of having been informed about sustainability issues, the risk of earthquakes and the importance of façade materials from a safety and security point of view.

The physical interview was carried out across all age groups, whereas only people under 45 years participated in online interviews.



**Table 3** Most Prominent Façade Typologies in Tehran

STYLE COMMON NAME *	CONSTRUCTION PERIOD	DOMINANT COLORS	FORM	STRUCTURE	ROOF	OPENINGS	DECORATION	SUSTAINABILITY
Roman Style 	2008 to today		This emerging style try to imitate the western classical architecture elements with the usage of modern stone and sometimes cement.	Metal or reinforced concrete	Flat roof	The metal simple windows which usually don't communicate with the form of other parts and decorations.	The decorative, not supportive columns that do not follow the form of 5 basic columns of classic architecture.	i. There is no control on the strength of joints between the stone tiles and the underneath wall. ii. The higher costs of construction iii. The high amount of material embodied energy
English Style 	2010 to today		It is known as English style because the red brick usage. Usually it is combined with Travertine stone or other types of stone.	Metal or reinforced concrete	Flat roof	The simple rectangular openings sometimes with reflective or mirror glass.	Modern decorations with different volumes subsided and projected.	i. The bricks are locally produced ii. They are suitable to resist earthquakes iii. The color does not match with Tehran context and identity.
Composite Style 	2010 to today		The series of aluminium sheets with different colors and dimensions.	Metal or reinforced concrete	Flat roof	Sometimes with strange window forms and colors	The combination of strange colors and some modern forms	i. There are proper for energy saving. ii. They are not locally produced and are imported from foreign countries. iii. The large aluminium sheets are not suitable to resist earthquakes.
Travertine Style 	The second half of eighties to today		The travertine stone exists in any form and color combine with other materials and sometimes curtain walls	Metal or reinforced concrete	Flat roof and in some cases inclined roof	Any form of opening with aluminium and sometimes wooden frames	Many types of decoration styles	i. There is no control on the strength of joints between the stone tiles and the underneath wall. ii. It is not economic. iii. It is preferred for internal floors not wall.
Granite Style 	The second half of eighties and the beginning of nineties to 2000. Today they are not common.		The granite stone exists in any form and usually dark colors	Metal or reinforced concrete	Flat roof and in some cases inclined roof	Any form of opening with reflective glasses	Not very decorative	i. There is no control on the strength of joints between the stone tiles and the underneath wall. ii. It is preferred for internal floors not wall
White Cement 	It was very common in the beginning of the nineties. Although in recent years they are some new buildings with this style.		The majority of white cement facades are with curve forms	Metal or reinforced concrete	Flat roof	Simple or curved opening with reflective or normal glasses	With western classic architecture elements	i. It is a locally produced and very economic material which it's combination with brick is beautiful. ii. It should be tinted and washed every 5 years.
Decorative Brick 	1980-1995 Although this kind of bricks are not popular today, the remnants of this building typology are the more aesthetic ones.		The simple more local forms	Metal or reinforced concrete	Flat roof	Simple or curved opening with reflective or normal glasses	Not very decorative	i. The bricks are locally produced ii. They are suitable to resist earthquakes iii. The color is as the same of old buildings iv. The light color is proper for Tehran climate

\* The common name: The name of style that is popular in real estate market.

In response to the question about the most beautiful façade option, 65 per cent preferred the “Roman” façade, 12 per cent selected aluminium covering and 18 per cent opted for granite stone. Only 6 per cent selected the traditional bricks to be used for building façade.

In all, it can be concluded that the level of public knowledge about the area of concern is relatively low. Particularly, the younger age groups know very little about the history of the city and its aesthetic and environmental aspects.

Another question was about the best suitable façade type in case of earthquake. Only 18 per cent selected bricks, the rest said that light coloured stone would be a suitable option.

**Table 4** First Stage Results

Personal Information	Women		23	
	Men		25	
	Total		48	
	owner		11	
	Tenant		37	
	Age	less than 20		194
		20-35		201
		35-45		242
		45- 55		298
		more than 55		65
	Residence in neighborhood	less than 5 years		2
		5-10 years		122
The previous neighborhood or residence city	10-20 years		398	
	more than 20 years		480	
	Tehran		787	
Residence Information	n. of floors	Other cities	213	
		0-4	393	
		4 to 8	605	
		more than 8	2	
	the age of building	less than 5	555	
		5 to 20	212	
		more than 20	233	
	The façade material	light stone like travertin	455	
		dark stone like granite	105	
		glass (curtain wall)	0	
		composite(aluminium)	11	
		brick	198	
		decorative brick	111	
		cement	35	
		decorative cement	85	
	The window type	normal rectangular	997	
		other forms	3	
	window glass type	normal	629	
		reflective	90	
		coloured	27	
double or triple		151		
both double and reflective				

Common taste and knowledge	The best photo selection	1. Granite façade	183
		2. Brick façade	60
		3. Roman façade	636
		4. Composite façade	121
	The most sustainable material	light stone like travertin	403
		dark stone like granite	3
		glass (curtain wall)	0
		composite(aluminium)	321
		brick	5
		decorative brick	183
		cement	0
		decorative cement	85
Neighborhood Info.	The most beautiful neighborhood building	residential	856
		cultural and museum	109
		mosque	35
	The preferred neighborhood public space	cultural space	121
		park	314
		mosque	25
		nothing	540



Figure 7. Analysis Diagrams



## Conclusion

The architectural design, construction material, and the view of buildings are directly linked to the aesthetic, safety and sustainability dimensions of cities. Due to its rapid physical growth, Tehran has essentially failed to grow in a harmonized and sustainable way. Hence the role of public opinion in determining the urban features of the city has been considerably neglected. The emergence of electronic media has created a great potential to facilitate public communication. Thoughtful use of such media can help raise the awareness and responsibility of citizens towards the management of their cities. Such an approach should begin with a pilot phase and at small-scale (one neighbourhood). Public cooperation and political will of local authorities, availability of social media and a desire for change are among the main factors of integrating public participation into urban decision-making.

Research has revealed the following summary conclusions:

- There is a general desire by citizens to participate in urban decision-making and openness to use the ICT instruments. While it may be too early to make an evidence-based conclusion on the usefulness and practicability of web-based interaction with the public vis-à-vis architectural aspects of urban development (e.g. diction-making on building façades), the preliminary feedback is quite promising. For instance, citizens have shown much interest when informed

of relations between building façade and seismic risks, given the quake-prone nature of Iran as a whole, and Tehran in particular.

- There is a need for building a three-way trust between citizens, constructors and urban managers and a need for systematic relations between the three parties by establishing rules and regulations as well as an enabling environment.
- Generally there is a lack of public awareness about the links between architectural and aesthetical features of buildings and the safety and sustainability aspects.
- Changing regulations, enforcement shortcomings and frequent changes in management of urban areas have an adverse impact on participatory approaches to urban management.
- So far, the communication between citizens and professionals active in urban planning and management remains sporadic and non-systematic, despite the interest and enthusiasm on both sides. However, with the sharp increase in the coverage of and access to electronic media, this relationship will be significantly improved.
- The project team is in the process of developing a dedicated website and specific software for façade design to be used in the future. However, use of the website would be in serious doubt unless a well-organized advocacy campaign is carried out.

## References

### Authored book:

- Mozayeni, M. (1995). *Municipal Management in Iran, Problems and Possibilities*. Tehran/Iran: Tehran Ministry of Housing and Development, National Organization for Land and Housing.
- Madanipour, A. (1998). *The Making of A Metropolis, Tehran*, (World cities series), Chichester: Willy.
- Kiani, M. (2002). *The Architecture in the First Period of Pahlavi Dynasty*, Tehran/Iran: The Institute for the Studies on Iran History.
- S-Haghighi, B. (2007). *The Progress of E-Governance in Iran*. Blekinge Institute of Technology.

### Journal article:

- Mehdizadeh, J. (2004). An Overview to the Spatial and Physical Development of Tehran, *National Journal of Jostarhaye Shahri (Farsi)*, 2-2001.
- Yaghoubi, N. M., A. Haghi, S. Khazaei (2011). E-government and Citizen Satisfaction in Iran: Empirical Study on ICT Offices. *World Applied Science Journal* 12 (7): 1084-1092, 2011.

### Published proceedings:

- Mohammadi, H. (2010). *Citizen Participation in Urban Planning and Management, The case of Iran, Shiraz City, Saadi Community*. Kassel University Press, Germany.
- Rezazadeh, F. et al. (2011). A SWOT and PEST Analysis of e-Governance in Iran. *5th Symposium on Advances in Science and Technology in Iran*.
- Tehran Municipality (2014). *Tehran City Rehabilitation: Concepts, Activities, and Future Approaches*.

### Website:

- ILO (2010). *New Minimum Wage Rate Spurs Widespread Indignation*, Iran Labor Report, 16 March 2010. Available from: <http://www.ilo.org/dyn/travail/doc>
- Ashrafologhalaei, A. (2005) *e-Governance, e-State in Iran – Administrative Reform Plan*. Available from <http://www.engagingcommunities2005.org/abstracts/Ashrafologhalaei-Ahmadreza-final.pdf/>

### Policy Documents:

- Municipality of Tehran (2014). *Guideline for the Design and Monitoring of Urban Building Façade*





# Geographic Information Systems and Policy Coordination in a Strategic Spatial Planning

## Context: Problems and Possibilities

○ Francis Kintu

University of the Witwatersrand, South Africa.

### Abstract ○

The use of geographic information and information communication technologies (Geo-ICT) such as geographic information systems (GIS) in decision-making processes of strategic spatial planning is due to the advanced spatial information processing and spatial information management properties of GIS. In this respect, GIS offers valuable support by facilitating the production, use and exchange of spatial information for use in designing sustainable cities.

Participatory planning is at the core of spatial planning processes. Deploying GIS as a platform of participatory

support in spatial planning broadens civic engagement in spatial planning; this creates more possibilities for the use and exchange of spatial information among stakeholders during collective decision-making activities of planning.

This chapter describes GIS support to spatial planning in the City of Johannesburg and the challenges associated with this. It proposes recommendations germane to upscaling GIS operability for supporting participation in spatial planning. The chapter ends with conclusions adduced from the deliberations duly presented.

#### Keywords:

Strategic spatial planning, policy coordination, integration, e-governance, participatory geographic information systems, local spatial knowledge.

## Introduction

The unprecedented rise in the rate of urbanization in developing countries and its associated planning challenges has elevated the status of strategic spatial planning as an appropriate planning tool capable of dealing with the challenges of rapid urbanization.

As a suite of innovative tools that focus on place-specific qualities as well as providing the means of translating visions, values and ambitions into practical programmes of governance, investment and management that engender spatial change, strategic spatial planning possesses sufficient transformative clout capable of producing resilient and sustainable urban spaces (Albrechts and Balducci, 2013, Clark, 2011).

The successful implementation of strategic spatial plans at the local government level is heavily dependent on the horizontal and vertical coordination of spatial policy between various public and private planning stakeholders. Effective coordination of spatial policy in this respect requires innovative mechanisms to provide support for participatory activities linked to spatial planning. Key elements among these innovative mechanisms are information technology (IT) applications that facilitate the exchange of spatial information between government and non-government planning stakeholders.

It is in the context of policymaking that e-governance as the use of IT applications in facilitating participatory planning, gains strategic value in spatial planning. Crucial in this regard is that IT applications enable innovative ways of civic engagement in planning processes, which has salutary impacts on the coordination of policy in city spatial planning.

Of enormous significance in this regard is the application of GIS in spatial planning where spatial information is a key ingredient in placemaking activities. GIS and its properties add innovative value in the ways in which spatial information can be produced, exchanged and used in strategic spatial planning processes. As such, GIS becomes a key enabler of spatial policy coordination among the diverse "ecologies of actors" (Evans, 2002) by helping facilitate interactions among stakeholders based on the exchange of spatial information. This helps consolidate the integration of policy at vertical and horizontal levels of governance in cities.

This chapter investigates the usage of GIS in spatial planning in the City of Johannesburg with specific reference to participatory support. It starts by describing the processes of strategic spatial planning and how they are associated with participation, spatial knowledge and spatial knowledge management tools in issues of spatial policymaking. Using the City of Johannesburg as a study context, the chapter gives a depiction of GIS use in local spatial planning processes in the city and the problems experienced in this respect. A number of recommendations are presented as a way forward as well as suggestions for further research.

## Background

### Strategic Planning Policymaking, Local Spatial Knowledge and Integration

Strategic spatial planning is "a transformative and integrative, public sector-led but co-productive socio-spatial process through which a vision and frames of reference, the justification for coherent actions and means for implementation are produced that shape and frame what a place is and might become" Albrechts (2006:1152). This definition highlights the value of "transformative processes and activities of a socio-spatial kind" that play a significant part in placemaking processes.

Space, place or locality is the central arena where placemaking activities embodied by "co-productive socio-spatial processes" of strategic spatial planning occur. By focusing on a limited number of key strategic issues; by integrating all factors that shape space in placemaking processes; by developing long-term visions and strategies; by allowing diverse stakeholder involvement in strategic planning, strategic spatial planning aims to produce quality sustainable and liveable spaces (Albrechts, 2012).

As such, "integrative public-sector-led, co-productive socio-spatial processes" that shape urban space allude to forms of urban governance such as interactive strategies, consensus building techniques and the mobilizing of coalitions that support cooperation and collaboration between government and non-government stakeholders (Healey, 1998). In a spatial planning milieu, these "co-productive socio-spatial processes" are manifested in the operation of inclusionary policymaking processes where "ecologies of actors" (Evans, 2002) as represented by public, private and civil society organizations engage in the active co-production of spatial policy, through activities of deliberation, joint framing and joint visioning (Albrechts, 2012, Van den Broeck, 2008).

Inclusionary policymaking processes refer to open, decision-making activities that involve communities in issues related to local placemaking; at the core of inclusive policymaking processes are mechanisms that create "inclusive spaces" as arenas that broaden the range of public engagement in urban placemaking processes (UN-Habitat, 2003). These



AS PART OF ITS SMART CITY PROGRAMME, THE CITY OF JOHANNESBURG HAS INTRODUCED THE CITIZEN ENGAGEMENT PLATFORM, AN ONLINE FACILITY REPORTING PLATFORM THAT HAS A DOWNLOADABLE PHONE APPLICATION. RESIDENTS CAN LOG ONTO THE PLATFORM AND REPORT INFRASTRUCTURE DELIVERY PROBLEMS IN THEIR LOCATIONS BY SENDING MESSAGES FROM PHONES.



mechanisms facilitate collective processes of deliberation that harness reservoirs of local spatial knowledge resident in urban communities that are important in spatial planning (Pfeffer et al., 2010). Local spatial knowledge consists of community knowledge of land and space characteristics that are unique to a place among other aspects (Mc Call, 2004).

Local spatial knowledge is an important variable in urban placemaking processes. “Inclusive spaces”, by helping broaden the involvement of communities in planning, stimulate the generation of “participatory spatialized knowledge” which is integrated with expert, technical spatial knowledge in activities of designing sustainable urban spaces (Baud et al., 2013, Pfeffer et al., 2011, UN-Habitat, 2003).

An in-depth understanding of urban community priorities, plus the comprehensive knowledge of locations in urban communities is indispensable in placemaking processes. In effect then, the design of sustainable and resilient urban spaces (Albrechts, 2012, Baud et al., 2013, Van den Broeck, 2008), is highly dependent on the reservoir of “participatory spatialized knowledge” created during inclusionary policymaking processes of joint negotiation, deliberation and discussions involving government and non-government stakeholders (Baud et al., 2013).

The production of participatory spatialized knowledge in a spatial policymaking context is assisted by “spatial knowledge management tools”, or “stakeholder engagement tools”. These tools aid the production, use and exchange of participatory spatialized knowledge and expert, technical information between planning stakeholders in policymaking processes (Newton and Glackin, 2013, Pfeffer et al., 2010).

By aiding the flow and exchange of spatial information between stakeholders, spatial management tools assist in enabling communication and interaction processes in the planning context, thus enhancing the coordination of spatial policy. Policy coordination or integration in this respect refers to activities of cooperation, coordination and collaboration that address consistency of policy implementation in planning (Keast, 2011, Keast et al., 2009, Stead and Meijers, 2009)

The level of policy integration is dependent on the quality of the exchange of spatial information or resources (e.g. spatial data and



IN AN URBAN E-GOVERNANCE ENVIRONMENT, ICT APPLICATIONS FACILITATE EFFECTIVE DECISION-MAKING BY ENHANCING COMMUNICATION BETWEEN GOVERNMENT AND CITIZENS, AND WITHIN AND BETWEEN COMMUNITIES (PASKALEVA, 2013).



maps) between stakeholders. Greater flows or exchanges of spatial information and resources between stakeholders result in stronger integration of policy. Conversely, infrequent communication flows, poorly established information sharing processes and the non-pooling of spatial resources between planning stakeholders produce weak or low-intensity integration as table 1 shows.

**Table 1** Levels of Integration (Keast et al., 2007).

COOPERATION	COORDINATION	COLLABORATION
Infrequent, ad hoc communication flows	Structured communication flows	Frequent communication, Thick communication flows
Tacit information sharing	Formalized, project based information sharing	Tactical information sharing
Loose connections, low trust	Medium connections, work based trust	Dense, inter-dependent connections, high trust
Resources remain with organization	Joint policies, programs, aligned resources	Pooled, collective resources



In an urban e-governance context, spatial knowledge management tools (Newton and Glackin, 2013, Pfeffer et al., 2010) in the class of geographic information and information communication technologies (Geo-ICT) such as geographic information systems play a significant role in the integration of policy in spatial planning.

## E-Governance and GIS

E-governance is defined as the use of ICT applications in supporting local governance processes (Waema and Adera, 2011). It is also defined as the use of ICT technologies in enhancing intergovernmental relationships for purposes of advancing democratic expression and encouraging delivery of services, among other issues (Riley, 2001). Deploying ICT applications in spatial planning creates innovative ways of civic engagement that assist in strengthening the integration of spatial policy in placemaking processes.

In an urban e-governance environment, ICT applications facilitate effective decision-making by enhancing communication between government and citizens, and within and between communities (Paskaleva, 2013). ICT applications e.g. web portals offering content, WebGIS, online databases and social media applications nurture and support e-inclusion and e-participation processes in policymaking processes.

The integrated city e-governance model (Paskaleva, 2013), shown in figure 1, is instructive in this regard. This model conceptualizes an environment in which ICT applications forge a citizen-centric, democratic and responsive policymaking process characterized by open and participatory planning. In this context, geographic information and information communication technologies (Geo-ICT) such as geographic information systems reform the city planning landscape by deepening interactive relationships between planning stakeholders, by dint of facilitating continuous two-way communication processes between public, private and civil society organizations (Paskaleva, 2013).



Figure 1. The City e-Governance Model (Paskaleva, 2013).

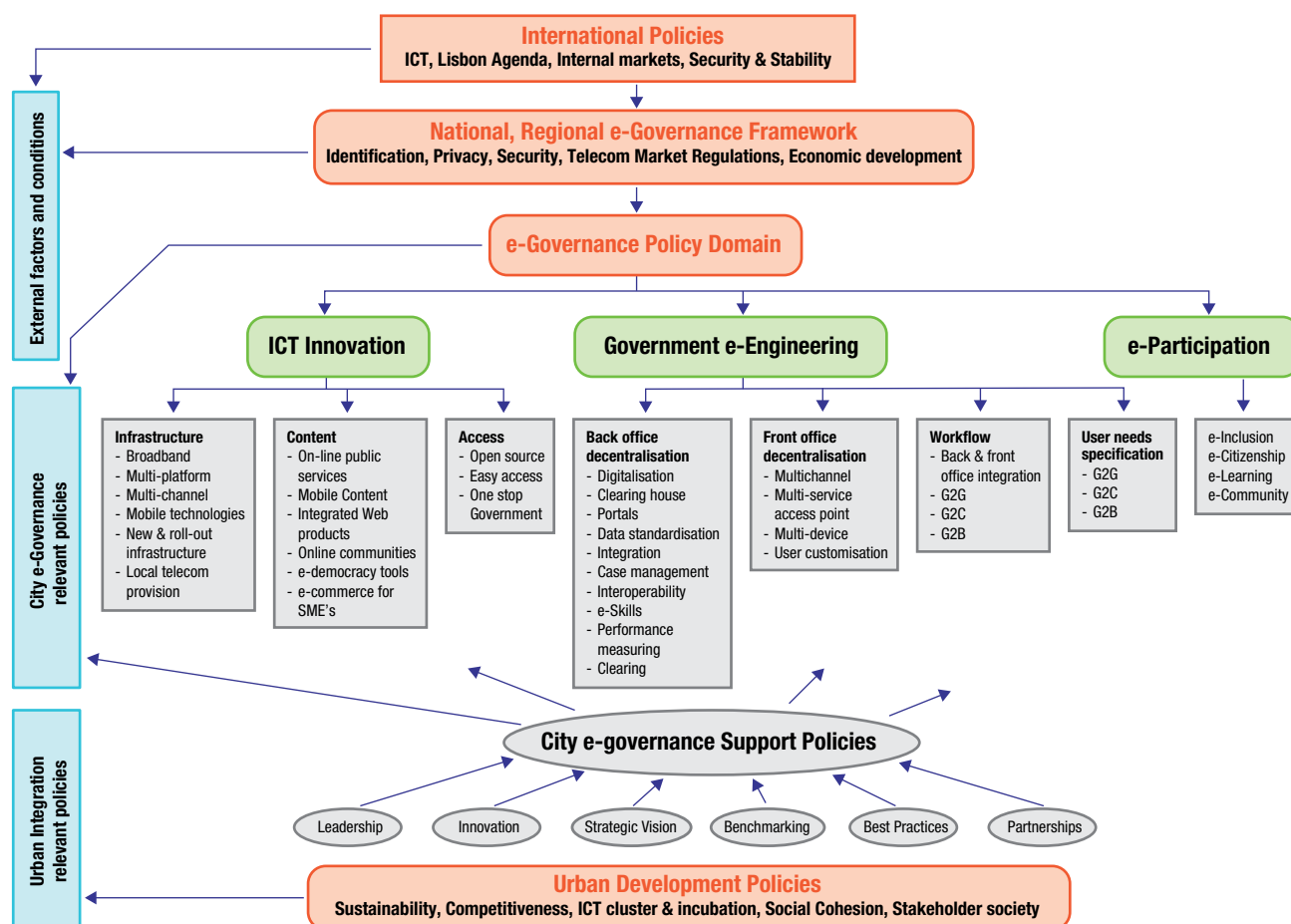

In a collaborative e-governance context, geographic information systems (GIS) defined as “a computer system capable of assembling, storing, manipulating, and displaying geographically referenced information” (USGS, 1997) support spatial planning by aiding the production and exchange of geographic information among stakeholders during policymaking activities. The evolution of GIS from desktop-based GIS to Internet GIS and finally to the Geospatial Web 2.0 platform has augmented the collaborative potential of GIS to support participation activities in spatial planning.

In this respect, Geospatial Web 2.0 applications embedded with Extensible Markup Language (XML) open new vistas of participation aided by dynamics such as the ability to produce and share maps online; the ability to combine spatial information from different sources into one web service by using Application Programming Interfaces (API's) as well as allowing seamless integration with all computing patterns (e.g. database centric, and server centric) and 3G mobile telephony (Ganapati, 2010).

The ability of linking 3G mobile phones embedded with GPS and Internet functions that support mobile mapping with Geospatial 2.0

applications raises the bar of collaboration even further. “Real time” geographic information can be produced and exchanged by citizens in issues such as reporting the location of potholes, water leaks and other matters associated with infrastructure delivery.

Using the web, urban communities can create, assemble and disseminate spatial data and maps; citizens can use the web to produce and publish maps that can be used to inform city spatial planning. As such, citizens become active participants in spatial planning processes by producing spatial information that is integrated with technical, expert spatial information in order to inform policymaking related to the designing of cities.

From an e-governance perspective, using GIS in participatory planning or public participation geographic information systems (PPGIS) enhances community inclusivity in the making of spatial strategies; it also strengthens interactions between government and non-government stakeholders in placemaking processes.

PPGIS intensity in policymaking can be measured by levels that rank from lowest to highest as shown in table 2.

**Table 2** PPGIS Levels of Intensity, from Lowest to Highest (Bugs et al., 2010, McCall, 2004).

LEVELS/ INTENSITY	PROCESSES	DESCRIPTION
Level 1	Information sharing	One or two-way communication between 'outsiders' and local people; passive and low degree of participation and mostly one-way flow of technical & expert information only from the GIS system to the users. Involves the communication of technical information such as baseline and status reports.
Level 2	Consultation	Two-way flow of information exchange since it includes discussion between participants, planning officials and planning authorities.
Level 3	Map based discussion	Interaction between internal actors (local government) and external actors (non-government) stakeholders based on online maps. Commenting and discussion is done on specific objects of selected maps. Participants submit to planning authorities personal versions of their maps but are not actively involved in decision making processes including returns of their participation.
Level 4	Involvement in decision making	The highest stage when participants contribute actively and constructively to decision making processes.

PPGIS levels of intensity are determined by factors such as organizational, institutional and political factors that determine access to spatial data and resources. They are also influenced by the willingness and openness of local governments in sharing financial and informational resources necessary for PPGIS use (Ghose and Elwood, 2003).

Research about GIS use in participatory planning processes in Australia, Brazil, Canada, Finland, Italy, Spain and the United States shows the preponderance of one-way flow of spatial information between city governments and the public (PPGIS level one intensity). Two-way communication between municipalities and the public (PPGIS level intensities 2,3,4) is the exception rather than the rule, according to several case studies (Bugs, 2012, Campagna and Deplano, 2004, Conroy and Evans-Cowley, 2006, Lanza and Proserpi, 2009).

## The City of Johannesburg (CoJ) study

### Local Strategic Spatial Planning Processes

Johannesburg is the largest city in South Africa. It is managed by the City of Johannesburg Metropolitan Municipality that has the responsibility of implementing spatial planning. The city area is divided up in seven main regions as shown in Figure 2.

The City of Johannesburg's Growth and Development Strategy 2040 (GDS 2040) sets out the city's strategic spatial planning agenda that aims at implementing spatial transformation in the city using planning measures such as eradicating poverty, building an inclusive economy and building sustainable human settlements (CoJ, 2011, CoJ, 2012).

The City's Department of Development Planning working in conjunction with municipal-owned entities, sectors and departments (<sup>1</sup>), is responsible for the implementation of strategic spatial planning in the city.

Long, medium and short-term strategic spatial plans such as the GDS 2040, integrated development plans and three-year operational and capital budgets are the main planning instruments that deliver infrastructure (<sup>2</sup>) in the city. These plans conform to processes of

Figure 2. Map Showing the City of Johannesburg and its regions.



integrated development planning (<sup>3</sup>) that entail the aligning of local spatial planning with planning of other levels of government in formulating an integrated development strategy (<sup>4</sup>) that includes a spatial development framework.

Integrated development planning (IDP) processes require extensive participatory actions between government and non-government stakeholders in formulating spatial planning strategies. Participatory processes in integrated development planning processes are facilitated by representative forums consisting of stakeholder structure and ward committee members, who are represented by a diverse array of government and non-government stakeholders (<sup>5</sup>). Despite these arrangements, there are serious deficits in participatory planning that excludes the inputs of communities in local spatial policymaking processes (IDASA, 2010, Van Donk, 2012, Winkler, 2011).

### E-Governance-related Processes in Spatial Planning

Citizen use of information technology for participation in integrated development planning processes in Johannesburg though minimal consists of cell phone and e-mail communication; a website for IDP document downloads; an e-service web portal; a municipal Facebook

page and a database that logs responses about service delivery issues (CoJ, 2006).

Planning with other levels of government is supported by the Integrated Development Planning Nerve Centre, a web-based information system that facilitates the flow of spatial planning information across levels of government. This system eases the coordination of spatial planning by aligning strategic planning with infrastructure investment decisions among other issues<sup>(6)</sup> (CoJ, 2009).

GIS support for the optimization of decision-making processes in strategic spatial planning is aided by the spatially enabled enterprise geodatabase (Land Information System) integrated with GIS that is used in the identification and management of development trends in the city (Momberg, 2014). In addition, the Capital Investment Management System (linked to the geodatabase) assists in the management of infrastructure delivery in Johannesburg. With regard to issues of spatial information access, the e-services web portal linked to the Land Information System offers access to spatial content to the public through the web portal. Figure 3 below shows the e-services web portal.

The e-services website allows access to spatial information such as stand numbers, street addresses, township names as well as subscription maps. It also gives access to full resolution aerial photography, detailed zoning information and information about proposed townships. The website has customized mapmaking tools that allow annotation. It also supports Drawing Exchange Format (dxf) and shape file (shp) downloads.

The e-services portal facilitates one-way communication between the city and the public by way of spatial information downloads (CoJ, 2012). Although the website has been ranked as the best in Gauteng Province in terms of the Web Assessment Maturity Index for content and services<sup>(7)</sup>, it is primarily configured to disseminate spatial data and not to support two-way, participatory activities.

The e-services website can only be accessed by those who have a working knowledge of GIS and have a computer with a reliable Internet connection. In addition, the website cannot be accessed using a mobile phone or a tablet. This limits its usage by those who can only access the Internet by using mobile phones and lack access to dial-up Internet (Momberg, 2014).

Figure 3. CoJ e-services Interface: <http://eservices.joburg.org.za/joburg/eservices#clkCntrl>

The screenshot shows the City of Johannesburg e-services web portal. The browser address bar displays [eservices.joburg.org.za/joburg/eservices#clkCntrl](http://eservices.joburg.org.za/joburg/eservices#clkCntrl). The page header features the City of Johannesburg logo and the tagline "a world class African city". A navigation menu on the left includes options like "Home", "Account by e-mail", "Corporate GIS", "Online Maps (GIS)", "Building Plan Progress", and "Valuation Services". The main content area displays "Online Maps (GIS) | Overview" and a list of services including "Full resolution Aerial Photography", "Proposed Townships", "Customised Mapmaking tools including annotation", "Dxf/shp file downloads (at an additional cost)", and "Zoning Information". A prominent yellow warning box states: "PLEASE NOTE: The online map viewer is only compatible with Internet Explorer 6 or higher...". The page also includes contact information for customer care and emergency connect.

As part of its Smart City programme, the City of Johannesburg has introduced the Citizen Engagement Platform, an online facility reporting platform that has a downloadable phone application. Residents can log onto the platform and report infrastructure delivery problems in their locations by sending messages from phones. A similar phone application developed for reporting road-related problems (the Find and Fix mobile app) has a geotagging feature that links Global Positioning System coordinates to images provided by the public. Both applications allow the public to engage with the city by providing it with real time information related to issues of infrastructure delivery.

Access to the e-services portal and logging onto the online facility reporting system is underpinned by Internet access and Internet affordability. In this respect, only 15.3 per cent of households in Johannesburg have access to the Internet and one in nine people have access to a personal computer. This is in comparison to 79 per cent of households with access to mobile telephony as a means of Internet access (SSA, 2013) as shown in figure 4 below:

Figure 4 shows issues of digital divide in Johannesburg with the greater number of households in the northern suburbs that have Internet access as compared with those in the southern parts of the city. These digital divide issues have an impact on the usage of ICTs for participatory planning. Even with the increased usage of mobile telephony as a platform of Internet access in Johannesburg, prepaid mobile telephony charges in South Africa are among the highest in Africa<sup>(8)</sup>. Internet affordability becomes a key determinant regarding the use of mobile phones as platforms of collaborative support in issues of participatory planning.

## Public Participation Geographic Information Systems and Policy Integration in Johannesburg

The usage of GIS in policymaking processes in Johannesburg is at the nascent stage of development. This is mainly due to the lack of Internet access in communities and the lack of GIS skills that limits access to the e-services website. According to table 2 that shows Public Participation Geographic Information Systems levels of intensity, PPGIS is at the basic level. This also indicates that GIS usage in policymaking is largely an institutional affair and not meant for supporting two-way participatory planning processes.

The insignificant role of the usage of GIS to support participatory processes in spatial planning has negative ramifications for issues of spatial policy coordination and integration. Deficiencies in civic engagement processes as a direct result of weak Public Participation Geographic Information Systems functionality limits the use of non-expert, local spatial knowledge in spatial policymaking processes.

Limited inclusion of local spatial knowledge in city spatial planning weakens processes of horizontal policy integration between government and non-government stakeholders, resulting in a situation where spatial planning in some instances runs counter to the demands of infrastructure delivery in Johannesburg (Laldaparsad, 2011).

With very little or no spatial information shared between communities and the municipality in spatial planning processes and with GIS resources remaining in the control of the city, the level of integration possible in this respect is at its most basic (table 1).

Figure 4. Maps Showing Levels of Internet Access in the City of Johannesburg (Gauteng City Region Observatory, 2014)

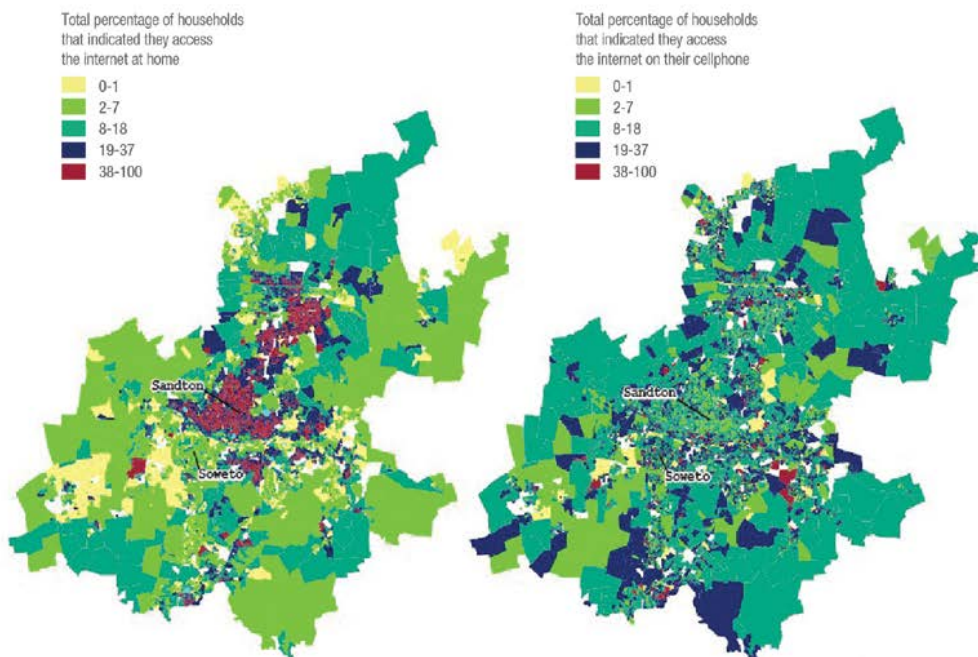



## Solutions and recommendations

South African Government policy documents affirm the role that ICTs have in promoting public participation in municipal planning processes. For example, the South Africa Local Government Association (SALGA) in some of its key policies advocates for the usage of ICTs in promoting e-participation as a means of deepening citizens' involvement in planning processes (SALGA, 2011, SALGA 2012). In particular, the Association emphasizes the need for municipalities in South Africa to scale up their levels of basic ICT maturity (e-government) to high ICT maturity (advanced e-governance) levels that can support IT-enabled participation in municipal planning (SALGA, 2012, SALGA, 2011).

It is these issues of accelerating IT to levels of high maturity that the City of Johannesburg needs to tackle in order for e-governance to play a meaningful role in supporting policymaking processes. In this respect, various ICT applications have the potential of supporting participatory activities in all stages of municipal integrated development planning as shown in table 3.

Interestingly, WebGIS is a major player in supporting participatory processes of integrated development planning. From a policymaking perspective, the municipality needs to develop the use of GIS in participatory planning with the intent of promoting effective public participation in integrated development planning.

This will require extending the usage of GIS from its institutional, top-down functionality to embrace bottom-up functionality where it can be used by communities in facilitating the production and use of local spatial knowledge in municipal spatial planning activities.

In this respect, the interactive potential of WebGIS makes it a formidable platform that supports in collective decision-making. The combination of Internet interactivity, GIS technology and spatial knowledge (Bugs, 2012) of Public Participation Geographic Information Systems promote two-way spatial information sharing among decision-makers, active stakeholders and urban communities. This strengthens the level of policy coordination in strategic spatial planning activities.

It is imperative that Public Participation Geographic Information Systems (PPGIS) be developed in Johannesburg as a collaborative planning platform that empowers communities to participate in the creation of sustainable urban spaces by broadening civic engagement in decision-making activities of spatial planning. This will require the execution of the following strategic thrusts:

- Provision of accessible and affordable Internet: Local government policy must target the universal access of affordable Internet to households to enable easier access to online spatial content. International case studies prove the high correlation between Internet usage and online citizen participation (Schatteman et al., 2012).

**Table 3** Possible Uses of ICT Applications in Local Planning Processes.

PLANNING PHASE	METHODS FOR PARTICIPATION	KEY OUTPUTS	POTENTIAL ICT APPLICATIONS
<b>Analysis</b>	Community Meetings organised by the ward councillor Stakeholder Meetings Surveys and opinion polls (getting views on how people feel about a particular issue)	Assessment of existing level of development, priority issues or problems; Information on causes of priority issues/problems; Information on available resources.	E Services Web Portal; Web GIS; Facebook; Email; Mobile SMS
<b>Strategies</b>	IDP Representative Forum Public Debates on what can work best in solving a problem Meetings with affected communities and stakeholders	The Vision; Objectives; Strategies; Identified Projects	WebGIS; Facebook; Email, Mobile SMS
<b>Projects</b>	Representation of stakeholders on project subcommittees	Performance indicators; Project outputs, targets, location; Project related activities & time schedule; Cost & budget estimates	Internet Forums; Facebook; Online database
<b>Integration</b>	IDP Representative Forum	5 -year Financial Plan; 5-year Capital Investment Programme (CIP); Integrated Spatial Development framework or Plan; Integrated sectoral programmes (LED, HIV, Poverty alleviation, gender equity etc); Consolidated monitoring/performance management system; Disaster management plan; Institutional plan; Reference to sector plans	WebGIS; E Services Web Portal; Online database; Facebook; Internet Forums; Email; Mobile SMS
<b>Approval</b>	Public discussion and consultation with communities and between local government & non-government stakeholders.	The output of this phase is an approved IDP for the municipality. The IDP is duly published and made available for downloading.	Facebook; E mail; E Services Web Portal.

Furthermore, the city needs to invest in public Internet facilities in communities to provide fixed line Internet to communities that lack such access.

- **Developing mobile government:** The high percentage of people who use mobile phones to access the Internet in Johannesburg points to the value of implementing mobile government as a platform of PPGIS support. This will require configuring the e-services portal to support mobile two-way communication between the city and the public. Secondly, using mobile phones as platforms of accessing the web portal requires affordable pre-paid mobile cost connectivity, which is still high. Local government needs to work with provincial and national governments in ensuring cheap mobile call charges to facilitate easier Internet access.
- **Establishment of Partnerships:** Partnerships are instrumental to the functioning of PPGIS. Local government must initiate partnerships between itself and community associations; between itself and other public and private sector partners in issues related to the production and use of spatial information in spatial planning. The example of Trinidad and Tobago in 2011 is instructive in this respect. Partnerships forged between local governments and organizations in the public and private sectors, as well with international organizations and communities were instrumental in PPGIS activities that helped formulate local responses to climate change (PPGISNetBlog, 2014).
- **Supply of GIS resources:** PPGIS supported policymaking requires the availability of GIS resources (software and hardware) for usage in producing spatial information. Local government working with public and private sector partners can help secure non-proprietary open source software that can be used by communities in producing local spatial information. Furthermore, local government needs to provide IT hardware such as GIS databases that can store community spatial data. The City of Johannesburg's "Integrated Smart Technology Programme"<sup>(9)</sup> can provide GIS databases to urban communities that can be used for storing user-generated spatial information such as volunteered geographic information.
- **Open Standards:** For purposes of easier online spatial data access, use and exchange, the City of Johannesburg must adopt the usage of open geospatial consortium standards. This allows the interoperability of different spatial data formats and enables the seamless integration of user-generated spatial information (e.g. volunteered geographic information) with other spatial data formats during planning. Open Standards also allow the public to produce, edit and publish map layers online.
- **Spatial literacy and GIS skills training:** Extending the use of GIS from its desktop-based planning functionality in order to support participatory planning relies on the availability of GIS skills in communities. Under its "Smart Citizen Programme"<sup>(10)</sup>, the City of Johannesburg, working with various partners, can provide basic GIS skills training (e.g. mapping skills) that will enable citizens to generate spatial content for use in planning. A good example in this respect is the Community Geography Project in Portland, Oregon, where the Metropolitan City Council worked with the Ford Foundation and academic institutions in helping provide GIS skills training for people in the community for the purpose of developing and enabling PPGIS (Merrick, 2003).
- **Integrating IDP planning with mapping activities:** Local government

needs to encourage ward committees in urban communities to engage in collective mapping tasks (participatory mapping) as part of developing PPGIS. Integrating participatory mapping with integrated development planning participatory processes can ensure the production of maps that are highly relevant to community infrastructure needs. Good examples of this are in India and Uganda, where citizens in cities take an active role in mapping activities that support city spatial planning processes (CitiesAlliance, 2011, Hoyt et al., 2005).

Notable in the aforementioned recommendations is the active role that local government plays in providing resources for developing the growth of Public Participation Geographic Information Systems for purposes of deepening participation in spatial planning. Notable too is the need for flexibility on the part of local government in terms of providing an open institutional environment that allows the usage of local spatial information in policymaking processes.

An example of Public Participation Geographic Information Systems best practice that deserves emulation is in Peru, where local governments working with communities have developed ICT-GIS-KM (knowledge management) systems that integrate local community knowledge into local spatial planning. Local government authorities have taken an active role in working with urban communities in producing local spatial knowledge that is used in spatial planning (Baud et al., 2013).

## Future Research or Operational Directions

Clearly, Public Participation Geographic Information Systems have a pivotal role to play in anchoring participation in strategic spatial planning in Johannesburg. How best PPGIS can be configured and optimized to operate as a collaborative vehicle that can support participation in the context of Johannesburg needs to be fully researched. Given the successes of PPGIS in empowering communities in other developing countries such as Peru and India (Baud et al., 2013, El Nabbouta et al., 2007), there are substantial grounds for conducting comparative case studies that can reveal insights into how GIS can be used for supporting urban community bottom-up policymaking activities.

The increasing usage of mobile telephony as the premier mode of Internet access in Johannesburg households points to the potential of exploiting mobile government (m-government) as a communicative platform of PPGIS support. Research is indispensable in determining what ways m-government can be deployed as a medium for supporting policymaking with specific reference to what strategies that are needed to integrate m-government in municipal spatial planning processes and how to incorporate m-government in municipal IT governance frameworks.



## Conclusion

Having deliberated on the merits of GIS as a versatile enabler of participatory planning and having discovered the factors that nurture its functionality in policymaking, the onus lies with the City of Johannesburg in taking bold and persistent measures in extending the use of GIS to support integrated development planning. This will require the deployment of GIS resources in communities with the express intent of strengthening bottom-up planning processes.

This will also require using GIS strategically not as a mere add-on or an appendage to local policymaking but as a tool of enabling empowered participation in city spatial planning. It is only in this way that the real potential of GIS can be exploited in helping close the deficits in civic engagement that plague strategic spatial planning in Johannesburg.

## References

- ALBRECHTS, L. 2012. Reframing strategic spatial planning by using a coproduction perspective. *Planning Theory*.
- ALBRECHTS, L. & BALDUCCI, A. 2013. Practicing Strategic Planning: In Search of Critical Features to Explain the Strategic Character of Plans. *disP-The Planning Review*, 49, 16-27.
- BAUD, I., SCOTT, D., PFEFFER, K., SYDENSTRICKER-NJ, DENIS, E., CONSUELO, L. & M, M. 2013. *Spatial Knowledge Management in Urban Local Government: E-Governance in India, Brazil, South Africa and Peru*.
- BUGS, G. 2012. Assessment of online PPGIS study cases in urban planning. *Computational Science and Its Applications-ICCSA 2012*. Springer.
- BUGS, G., GRANELL, C., FONTS, O., HUERTA, J. & PAINHO, M. 2010. An assessment of Public Participation GIS and Web 2.0 technologies in urban planning practice in Canela, Brazil. *Cities*, 27, 172-181.
- CAMPAGNA, M. & DEPLANO, G. 2004. Evaluating geographic information provision within public administration websites. *Environment and planning B*, 31, 21-38.
- CITIESALLIANCE 2011. *Transforming the Settlements of the Urban Poor in Uganda (TSUPU)*. Kampala: CitiesAlliance.
- CLARK, G. 2011. *Spatial & Strategic Planning in cities*. Auckland.
- COJ 2006. *Integrated Development Plan 2006 - 2011*. City of Johannesburg Metro Municipality.
- COJ 2009. *Assesment of economic projects and programmes in other spheres of government and adjacent municipalities to determine the possibility of developing synergies with the CoJ*. Johannesburg: City of Johannesburg Metro Municipality
- COJ 2011. *Integrated Development Plan 2011 - 2016*. Johannesburg: City of Johannesburg Metro Municipality
- COJ 2012. *Integrated Development Plan*. Johannesburg: City of Johannesburg Metropolitan Municipality
- CONROY, M. M. & EVANS-COWLEY, J. 2006. E-participation in planning: an analysis of cities adopting online citizen participation tools. *Environment and planning C*, 24, 371.
- EL NABBOUTA, K., BUCHROITHNERA, M. & SLIUZASB, R. 2007. A new visualization tool for participatory urban planning: the case of Tripoli, Lebanon. *Global Change Issues in Developing and Emerging Countries: Proceedings of the 2nd Göttingen GIS and Remote Sensing Days 2006*, . Göttingen, Germany.
- EVANS, P. 2002. *Livable cities?: Urban struggles for livelihood and sustainability*, University of California Press.
- GANAPATI, S. 2010. *Public participation geographic information systems: a literature survey*. Comparative E-government. Springer.
- GHOSE, R. & ELWOOD, S. 2003. Public participation GIS and local political context: propositions and research directions. *URISA Journal*, 15, 17-22.
- HEALEY, P. 1998. The place of Europe in contemporary spatial strategy making. *European urban and regional studies*, 5, 139-153.
- HOYT, L., KHOSLA, R. & CANEPA, C. 2005. Leaves, pebbles, and chalk: building a public participation GIS in New Delhi, India. *Journal of Urban Technology*, 12, 1-19.
- IDASA 2010. *The State of Local Government and service delivery in South Africa: issues, challenges and solutions*. Report issued to the Portfolio Committee on Cooperative Governance and Traditional Affairs (CoGTA) for public hearings on coordinated service delivery. Pretoria: Institute for Democracy in Africa, Local Government Unit.
- KEAST, R. 2011. Joined-up governance in Australia: how the past can inform the future. *International Journal of Public Administration*, 34, 221-231.
- KEAST, R. L., GLASBY, J. & BROWN, K. A. 2009. Inter-agency working: good intentions and interaction dynamics.
- LALDAPARSAD, S. 2011. The reshaping of urban structure in South Africa through municipal capital investment: Evidence from 3 municipalities. In: RESEARCH, E. P. (ed.). *Johannesburg: Statistics South Africa*.
- LANZA, V. & PROSPERI, D. 2009. Collaborativee-governance. Describing and pre-calibrating the digital milieu in urban and regional planning. *UDMS 2009 Annual Urban and Regional Data Management*, 373-384.
- MCCALL, M. Can participatory-GIS strengthen local-level spatial planning? Suggestions for better practice. 7th International Conference on GIS for Developing Countries (GISDECO 2004), , 2004 University Teknologi, Johor Malaysia.
- MERRICK, M. 2003. Reflections on PPGIS: A view from the trenches. *URISA Journal*, 15, 33-40.
- MOMBERG, M. 2014. *Exploring the dynamics and potential outcomes of an integrated information system for land use development: A case study of City of Johannesburg's Land Information System*. Wits University.
- NEWTON, P. & GLACKIN, S. 2013. Using Geo-Spatial Technologies as Stakeholder Engagement Tools in Urban Planning and Development. *Built Environment*, 39, 473-501.
- PASKALEVA, K. 2013. E-governance ad an enabler of the smart city. Deakin, M.
- PFEFFER, K., BAUD, I., DENIS, E., SCOTT, D. & SYDENSTRICKER-NETO, J. 2010. Spatial knowledge management tools in urban development: . *Information, Communication & Society Vol*. 16, No. 2, 258-285.
- PFEFFER, K., MARTINEZ, J., BAUD, I. & SRIDHARAN, N. 2011. Knowledge Production in Urban Governance Systems through Qualitative Geographical Information Systems (GIS). *Environment and Urbanization Asia*, 2, 235-250.

- PPGISNETBLOG. 2014. ICTs for Climate Change Adaptation: Introduction of innovative technologies in the Caribbean [Online]. Accessed 14 October 2014. Available from <http://participatorygis.blogspot.com/2012/09/icts-for-climate-change-adaptation.html> [ ].
- RILEY, T. B. 2001. *Electronic Governance in Context. Electronic Governance and Electronic Democracy: Living and Working in the Connected World.*: Commonwealth Centre for Electronic Governance.
- SALGA 2011. *Municipal Approaches to e-Participation*. Pretoria: South Africa Local Government Association.
- SALGA 2012. *Municipal E - Participation Pilot Project Workshop*. Pretoria: South Africa Local Government Association.
- SCHATTEMAN, A., MOHAMMED-SPIGNER, D. & POLUSE, G. 2012. Citizen Participation through Municipal Websites: A Global Scorecard. *Active Citizen Participation in E-government: A Global Perspective*, 403.
- SSA 2013. *General Household Survey*. Pretoria: Statistics South Africa.
- STEAD, D. & MEIJERS, E. 2009. Spatial planning and policy integration: Concepts, facilitators and inhibitors. *Planning Theory & Practice*, 10, 317-332.
- UN-Habitat 2003. *Inclusive Cities Initiative – The Way Forward*. The Global Campaign on Urban Governance. Nairobi: UN-Habitat.
- USGS 1997. *About GIS*. United States Geological Survey.
- VAN DEN BROECK, J. *Strategic Spatial Planning and Strategic Projects. A transformative practice*. 44th ISOCARP Congress, 2008.
- VAN DONK, M. 2012. Tackling the 'governance deficit' to reinvigorate participatory local governance. In: (GGLN), G. G. L. N. (ed.) *Putting Participation at the Heart of Development//Putting Development at the Heart of Participation*. Cape Town: GGLN and Isandla Institute. Cape Town: Isandla Institute.
- WAEMA, T. M. & ADERA, E. O. 2011. *Local governance and ICTs in Africa: case studies and guidelines for implementation and evaluation*, IDRC.
- WINKLER, T. 2011. Retracking Johannesburg Spaces for Participation and Policymaking. *Journal of Planning Education and Research*, 31, 258-271.

## Footnotes

1. These are City Power, Community Development, Corporate and Shared Services, Department of Economic Development, Development Planning and Urban Management, Emergency Management Services, Johannesburg Metropolitan Police Department, Environmental Planning and Management, Finance, Health, Housing, City Parks, Johannesburg Theatre, the Johannesburg Development Agency, Johannesburg Fresh Produce Market, Johannesburg Tourism Company, Johannesburg Water, Johannesburg Zoo, Joburg Social Housing Company, Johannesburg Property Company, Johannesburg Roads Agency, Metro Trading Company, Metrobus, Office of the Mayor, PIKITUP, Roodepoort Theatre, Transportation, Speaker Office, Revenue and Customer Relations.
2. By designation, Johannesburg's strategic spatial planning is linked to infrastructure delivery.
3. As a planning approach that integrates issues ranging from social, economic and environmental, in order to facilitate the optimal allocation of scarce resources in ways that provide local sustainable growth, integrated development planning is the principal strategic planning instrument of a municipality that guides and informs its planning, budget, management and development actions. It includes a Spatial Development Framework (DPLG, 2000).
4. These stakeholders are members of the City Council Executive Committee, heads of departments and senior officials from municipal and government departments, civil society groups, people representing the rights of unorganized groups, resource people or advisers, community representatives, ward councillors, ward committee members as well as representatives from organized stakeholder groups. Other forms of participation also exist such as izimbizos, mayoral roadshows and sectoral forums that facilitate engagement between local government and stakeholders from various sectors.
5. Other issues include: strengthening the link between local, provincial and national priorities and objectives, as well as supporting integrated infrastructure and service delivery in Johannesburg.
6. In 2010, the Website Maturity Index ranked the Johannesburg e-services website as the best in the Province of Gauteng, with a score of 88 per cent.
7. According to the recent Research 2012 ICT Africa Report, mobile call prices are cheaper in over 30 African countries than they are in South Africa with prices in Kenya, Mauritius, Egypt and Namibia only a fraction of the price of the lowest priced services in South Africa.
8. The Smart Citizen Programme is a key component of Johannesburg's Smart City programme. It envisages supporting ICT literacy, e-learning, innovation and citizen engagement with and via new forms of technology.
9. The Smart Technology Programme, which is also a part of the Smart City Programme, endeavours to deliver smart technology for Johannesburg communities such as smarttechnology-enabled metering for power regulation.





# E-Governance and Rural-Urban Continuum: Study in Indian Context

- Harekrishna Misra  
Professor, Institute of Rural Management Anand, India
- Sanjay Kumar Panigrahi  
Chief Executive Officer, Sahaj e-Village Limited, Kolkata, India

## Abstract

Globally, e-governance services are aimed at enhancing engagements among all stakeholders including citizen, government, business and civil society. Contemporary e-governance with focus on e-participation, e-collaboration and e-citizens deals with policies for citizen-centric services and fostering demand-driven citizen engagements. With web 2.0 and service-oriented architecture enabled technologies, tools and services e-governance policies are well supported in many countries with focus on citizen-centredness. Despite these advancements in technologies and enabling policies, all developing countries still grapple with rural-urban digital divides. However, e-governance policies to overcome these divides in many developing countries have provided evidence supporting the rural-urban continuum.

However, such interventions are not free from challenges related to innovations and managing transitions in e-governance system. In the Indian context, the situation is quite complex because of its geographic spread, diversity in socio-economic disparities and federal structure of governance. This situation has overarching effects on the digital divide and provided rich insights to support the rural-urban continuum. The National e-Governance Plan (NeGP) introduced in 2006 has now embarked on NeGP v.2.0. This chapter discusses the genesis of the plan and its contributions to the rural-urban continuum, opportunities and challenges it faces today. The chapter includes the case of Sahaj e-Village Ltd (SeVL), which is a constituent of the plan, and discusses its role in fostering the rural-urban continuum.

### Keyword:

E-governance, digital divide, digital inclusion, Web 2.0, service-oriented architecture, e-participation, e-collaboration, citizen engagements.

## Introduction

Globally, e-governance efforts are concentrated on citizen-centred services. The advent of web 2.0 technologies has paved the way for enhancing citizen engagements and fostering innovations in information and communication technology-enabled services. E-governance efforts today are focussed on convergence among entities including business, civil society, government and citizens. Evidently, the contributions of web 2.0 and service-orientated architectures have shown effective methods to bind people, process and technology for better participation, interaction and user orientation. With its main focus on citizen-centric services and providing backbones for demand-driven citizen engagements with the government, e-governance has the potential to embrace web 2.0 enabled technologies, tools and services and service-orientated architectures.

The Millennium Development Goals hold that e-governance, through its efforts to foster e-collaboration and e-participation, has the potential to engage citizens in managing their own development and the society at large (Misra, 2013). In the Indian context, this approach is essential though the situation is quite complex because of overarching effects of the digital divide. Despite continued efforts of the national and state governments under the National e-Governance Plan and citizen-centric information technology policies, there are various challenges in their implementation (DIT, 2011). Like any other developing country with an emerging economy, India faces the challenge of the rural-urban continuum. This challenge creates greater scope for the e-Governance Plan to innovate and render seamless services for citizens while embracing best practices in governance. The effort of Sahaj e-Village Limited, one of the state agencies under the e-Governance Plan, is noteworthy. The former has innovated services in an attempt to engage citizens in acquiring e-skills, orchestrates e-government services and meets the demand of citizens.

Organization of this chapter is as follows: In the following section various frameworks are discussed on transformation of services through e-governance, evolution of e-governance in a national context and the rural-urban continuum, and role of e-governance. Based on these frameworks, the next section includes discussions on the e-Governance Plan and its deliveries. In the next section opportunities and challenges faced by Plan are discussed. The following section focuses discussions on the Plan and its contributions to the rural-urban continuum. In the next section, the case of the Sahaj e-Village Limited is discussed. This case refers to the e-Governance Plan’s mandates and the process SeVL has adopted in implementing those mandates. This case-based discussion aims to assess the way the Plan’s services are oriented and the scope for their support to promote web 2.0 and service-orientated architecture-based amenities. The next section concludes with recommendations and future research direction.

## Frameworks for the study

this section includes discussions on topics based on two frameworks: (1) transformation of services through e-governance; (2) evolution of e-governance in a national context; and (3) the rural-urban continuum and role of e-governance.

## Framework for Transformation of E-Governance Services

This suggested framework argues that e-government is expected to pursue the best practices and engage with the constituents of e-governance stakeholders as a support structure. E-governance on the other hand, is expected to formulate policies and enact the engagements so that governments are transformed to e-governments. However, basic tenets of governance need to be the prime influencers for such transformation (Mehdi, 2005). As mentioned earlier, digital divides do reflect on the distinguishing behaviour of e-governance in different

Figure 1. Framework for Service Transformation in e-Governance

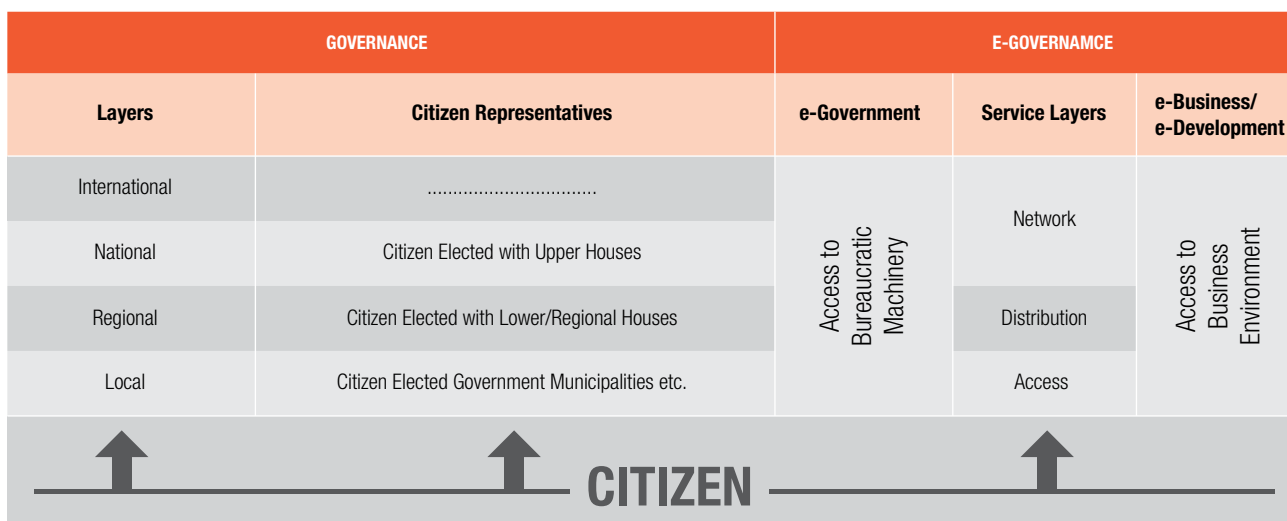

economies of the world. In figure 2, a generic e-governance framework is presented for the purpose. In the framework, it is argued that citizens are the prime movers of e-governance and thus all the services should be citizen-centric. The framework identifies three layers for rendering citizen-centred services: (1) network; (2) distribution; and (3) access (Garlan and Shaw, 1994, Misra, 2010b). It is important to note that any service that e-governance plans to deliver should take note of the service layers and ensure that the access layer gets the top priority, and that network and distribution layers support this process.

Studies indicate that e-governance has emerged as a national agenda for rendering citizen-centred service (Heeks and Molla, 2009; DIT, 2011). E-governance is fast transforming itself from well-networked e-government portals with passive information to agile information-driven service delivery systems on demand (West, 2008, Misra and Panigrahi, 2014). Many also argue that e-governance not only looks for establishing processes for SMART (Simple, Morale, Accountable, Responsive and Transparent) governments but also strives to meet the challenging dimensions of the digital divide (EU, 2007, Misra, 2013). Fundamentally e-governance, being ICT-driven, has most of its approaches influenced by software engineering process models. E-governance plans cover issues related to local, regional, national and international levels and, therefore, has the potential to be strategic information systems oriented (SSRIC, 2010, OECD, 2003, Misra, 2013).

## Framework for Understanding Evolution of E-Governance

The framework for evolution of e-governance is presented in figure 2. It shows a staged model in which activities are sequenced. It suggests that connectivity is a mandatory requirement for fostering e-governance in a national level. This stage is "readiness" and, therefore, the United Nations and the International Telecommunications Union are focusing on this issue. The subsequent stage is for deployment of e-governance services and is related to strategic information systems planning (SISP).

In addition to SISP, development informatics is the area that deals with such issues by learning from computing best practices available elsewhere to replicate in e-governance areas, and provide ambience for rendering services and facilitating uptakes. The third stage includes assessment of the impact of e-governance services in the context of its stakeholders. This stage is largely dealt with agencies involved in impact assessment and view e-governance as projects.

## Rural Urban E-Governance Continuum

The rural-urban continuum is a global phenomenon and argues against rural and urban divides. This paradigm postulates that rural and urban sectors complement each other and need to coexist in production, trade, information flow, governance and even managing institutions (Dewey, 1960; Pahl, R. E., 1966). The rural-urban continuum, therefore, favours the formulation of enabling policies, integrated infrastructure and the creation of platforms for convergence of services. This ambience is likely to forge dynamic links between business, sectors and geographical areas.

Figure 3 illustrates the complexities that the rural-urban continuum offers. The framework suggests that spatial flows need to be supported by information symmetry for effective utilization of resources and sectoral flows need adequate and seamless integration of the market (input and output), and expert-citizen interactions for value added services on demand (Dewey, 1960; Pahl, 1966). All these issues are multidimensional and the role of e-governance needs to be well articulated in supporting this continuum.

In this digital era the spatial and sectoral space in the society is diminishing very fast. Because of rapid urbanization and increased aspiration of the population; there is tremendous growth in migration, market orientation and demand in production and services in developing countries and emerging economies. While urban areas are looking for inputs for factors of production, predominantly labour and services from rural areas, it also targets the countryside as an emerging market

Figure 2. Framework for e-Governance Evolution (Heeks and Molla, 2009)

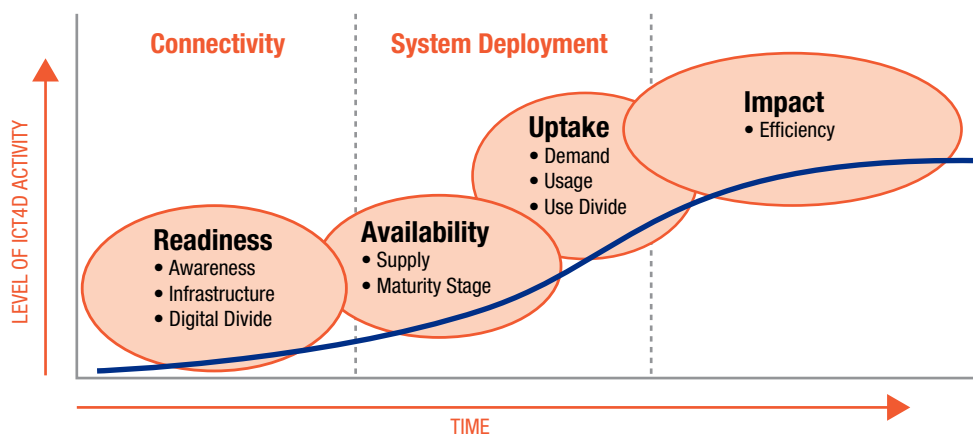
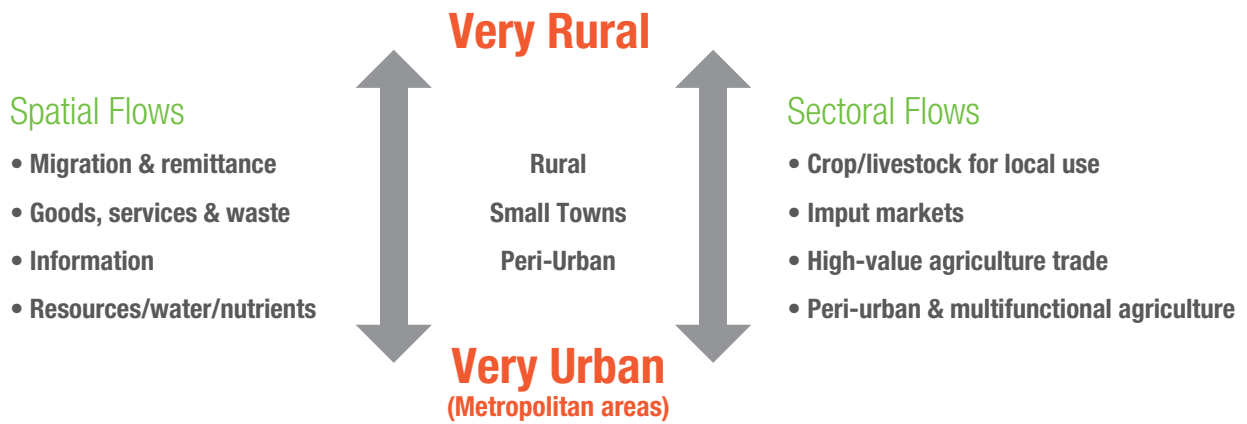



Figure 3. Rural Urban Continuum Elements (Braun, 2007)



for rendering channelized products and services. The reverse is also true, which suggests that increasingly rural folk are fast migrating to urban areas to better their lives. In developing countries and emerging economies, the rural sector is in transition as shown in figure 4. It may be noted that spatial flows deal with issues related to migration and related economic factors such as information as a service, flow of goods and services, sharing of resources. Besides this spatial flow, there is also sectoral flow which involves market oriented multi-functional agriculture relating to agri-business, agri-value chains, water resource management, and precision farming etc.

Such multi-functional, spatial and sectoral flows suggest that tremendous scope has been created by government, business and civil society for

transition of the rural community to a very urban society. This transition has provided common space for establishing continuum in steps i.e. A, B, C, D and E as shown in figure 4.

These steps can be seen as potential links in the value chain of the ecosystem in which the e-governance paradigm expects to intervene. These common spaces are very critical for assessment of the convergence of demand and services that could be captured in e-governance, and due steps are taken for innovative interventions. Many such innovations have taken place in the Indian context as part of the e-Governance Plan, though many of them are declared as successful whereas most need improvement. Such demands and services are listed in table 1 along with some of the associated interventions.

Figure 4. Rural Urban Continuum Common Elements

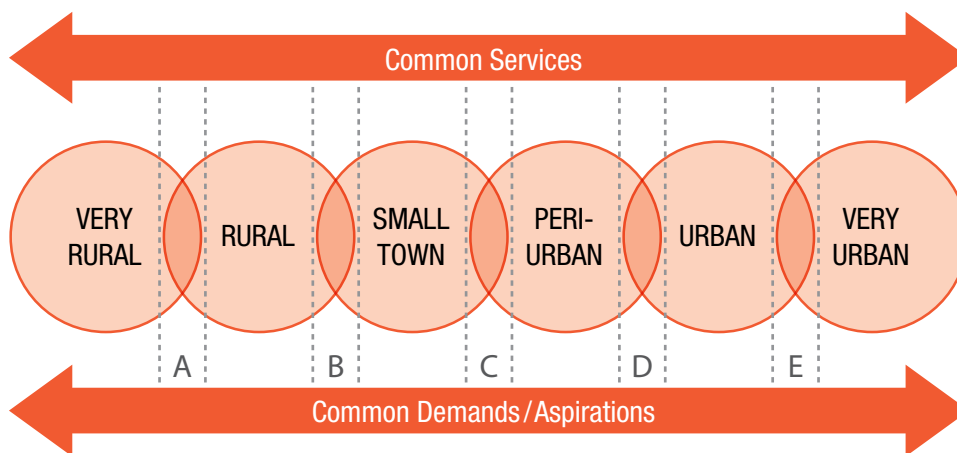

**Table 1** Common Elements in Rural-Urban Continuum (Demand and Services)

STEPS OF CONTINUUM	SECTOR		COMMON DEMANDS AND ASPIRATIONS	COMMON SERVICES
A	Very Rural	Rural	Income generation, Agriculture services, Land Records, Citizen rights, Skills and Education, Health, Infrastructure and Utilities, financial inclusion, insurance and banking services; input services with factors of production, supply chains and value chains across farm and non-farm sector	e-skill, e-education, e-utilities, e-land-records, e-transport, e-public-distribution, e-voting, e-insurance, net-banking, e-tailing, e-commerce, e-migration-information, e-supply chains, e-value chains, e-health, e-agri-services
B	Rural	Small Towns		
C	Small Towns	Peri-Urban		
D	Peri-Urban	Urban		
E	Urban	Very-Urban		

## Indian E-governance - NeGP

The Government of India embarked on implementing its National e-Government Plan in 2006. The Government recognized that ICT could be a prime mover for overall development of the nation and society through SMART government. The Government also recognized that - given the social, economic, cultural and demographic diversity in the nation - ICT could support networking among agencies involved in development, thereby rendering transparent services and reducing the need for intermediaries. Plan in its mandate focussed on rural services with the aim to reduce information asymmetry, provide citizens access to government services by reducing bureaucratic overheads, access to microcredit and financial inclusion services, and the platform to conduct business online. The Plan included 27 central, state and integrated mission mode projects. The main aim of the Plan was to establish infrastructure that could support delivery of “web-enabled anytime, anywhere access” to information and services in rural India. The Plan strategically included all components for its implementation. Its architecture is presented in figure 5. The constituents of the Plan’s architecture are the Department of Electronics and Information Technology (erstwhile DIT), the National Level Service Agency, the Special Purpose Vehicle, the State Government, the State Designated Agency, the Service Centre Agency, and Village Level Entrepreneurs. The Department of Electronics and Information Technology is a functional representative of the Government, spearheading the agenda. It guides, formulates strategies and monitors the e-Governance Plan for its overall success.

Figure 5. NeGP Architecture, DIT,(2011)

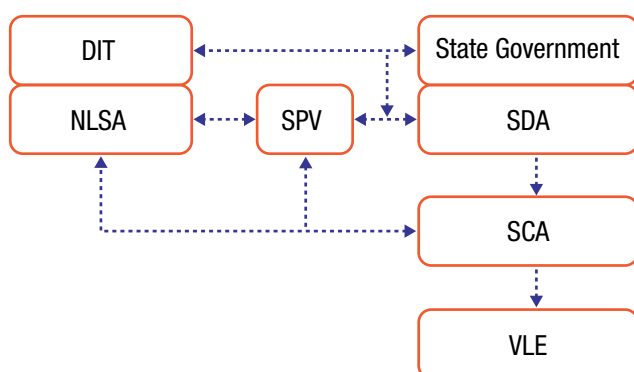

The National Level Service Agency works as an intermediating bureau to implement the project in a public-private partnership mode. The National Level Service Agency manages the project nationally and has the responsibility of aggregating best practices, networking content providers, and roll out of the plan across all states of the nation. The Special Purpose Vehicle has equity partners who would invest in this body such as Department of Electronics and Information Technology, the National Level Service Agency, and strategic investors. The equity capital of the Special Purpose Vehicle, in part, is also subscribed to by the Service Centre Agencies. The Special Purpose Vehicle is responsible for channelling Government support to National Level Service Agencies and liaises with the State Designated Agency. The Special Purpose Vehicle undertakes roles and responsibilities like (1) laying down operating and financial guidelines within the Common Service Centre system; (2) providing a framework for collaborative decision-making process; (3) catalysing and maintaining content aggregation on an ongoing basis; and (4) build a common identity. The Service Centre Agencies are expected to pay a fee to the Special Purpose Vehicle for all the above services. The State Designated Agency is an associate in the roll-out process under the public private partnership scheme and invests resources. It has three functions: (1) facilitator for policy, regulatory and other relevant changes with state governments; (2) facilitator for enabling e-government services; and (3) enabler for infrastructure and other support to the Service Centre Agency. This agency is the prime driver of the Common Service Centre ecosystem which has predefined areas of operations in a state. The Service Centre Agency undertakes activities including (1) identification of required applications and services; (2) harnessing the state network; (3) identifying and training the village level entrepreneurs; (4) establishing the Common Service Centres (either directly or through the village entrepreneurs); and (5) supplying, aggregating and updating content and services.

The Service Centre Agency is supported by the National Level Service Agency and the respective State Designated Agency to implement the Common Service Centre scheme. The Service Centre Agency is responsible for the overall profitability and sustainability of the Common Service Centre business, and facilitates implementation as well as provides policy guidelines occasionally, Government-to-citizen services, and disbursement of revenue support to the Service Centre Agencies.

The village level entrepreneur is the key to the success of Common Service Centre operations and is the last layer in the architecture. A good

**Table 2** NeGP Services

SERVICE LAYER	CONSTITUENTS OF NEGP	SERVICES RENDERED / PLANNED
<b>Network</b>	DeiTYI NLSA ISPV	MMPs (Central /Integrated); Creating networks for G2G, G2C, G2B, B2B and B2C environment
	State Government	MMPs (State   Integrated); Creating networks for G2G, G2C, G2B, B2B and B2C environment
<b>Distribution</b>	SPV	VLE Capacity building, managing web portal for orchestration of SDAs, VLEs; Liaison with NeGP stakeholders
	SDA	VLE development, Recruitment, B2C, G2C, B2B
<b>Access</b>	SCA	VLE networking, service demand aggregation, Service channelization
	VLE	Service identification, Service provisioning

village level entrepreneur is one who has good entrepreneurial skills, strong social commitment as well as respect within the community. The person is expected to manage the Common Service Centre business at the ground level. Therefore, all the constituents in the National e-Governance Plan architecture are responsible for selection of the village level entrepreneur and to train the person for the effective implementation of the Common Service Centres.

The current status of the e-Governance Plan indicates that every State Designated Agency in India has a website or web portals and they are connected to the Special Purpose Vehicle portal. These portals have the mechanism to interface with the website/portal of Service Centre Agencies to monitor performance of respective village level entrepreneurs. One such performance indicator is the "uptime" of the computer installed in Common Service Centres operated by the village level entrepreneur. This uptime is monitored through client software under client-server architecture and the Department of Information Technology monitors this software. Every SCA educates and counsels its VLEs and inculcates the value of citizen interface and one of them is to ensure that computer, internet connectivity and related infrastructure are ready for rendering services to citizens on demand. In addition, each state government compiles this information to compensate Service Centre Agency through State Designated Agencies for the services. While collaboration among agencies through web portals and synchronization of databases are available, software as a service is yet to come up for the National e-Governance Plan. As regards service orchestration, online features are yet to be implemented in the system and the Special Purpose Vehicle, the Department of Electronics and Information Technology and other agencies at state level are still struggling to acquire resources for implementing this service.

## Transformation of E-Governance Services through NeGP

Services under the National e-Governance Plan NeGP planned are presented in table 2.

As regards services, the e-Governance Plan has identified Mission Mode Projects as presented in Table 3.

Services listed in table 3 are specific to the central and state governments, while some are integrated across both. These integrated services, which

are independent of states and the centre, will be available seamlessly to all citizens. In addition to these services, efforts are being made by civil society, business organizations, and funding agencies to provide ICT enabled services. However, these services may be deployed and used with the availability of desired infrastructure. The success of these services would also depend upon adequate support by citizens who are otherwise challenged by many issues vis-à-vis Millennium Development Goals.

## Evolution of NeGP

Study on evolution of the National e-Governance Plan is based on the framework presented in figure 2. The Plan traversed the desired path as per the framework though its effectiveness is varied. They are discussed hereunder.

## Connectivity Readiness

As presented in figure 2, readiness involves awareness, infrastructure and digital divide. Awareness of the Plan is quite high because of its spread across all the states covering clusters of villages with Common Service Centres. These centres are owned and operated in the village by resident entrepreneurs. As regards infrastructure, the Plan requires all state governments to set up their state wide Area Networks; all the central ministries and state governments have operated their websites; State Designated Agencies have also provided online web services to village entrepreneurs and the Special Purpose Vehicle, which has made its portal operational to engage with the State Designated Agency and village level entrepreneurs for channelling the services. All the

**Table 3** Mission Mode Projects in India

MMP LEVEL	DESCRIPTION OF THE SERVICE
<b>Central Government</b>	Income Tax, Central Excise, Passports Visa & Immigration, MCA 21, National ID, Pensions, Banking, Insurance
<b>State Governments</b>	Agriculture, Land Records, Transport, Treasuries, Commercial Taxes, Gram Panchayats Registration, Police, Employment Exchange, e-Districts (State can add 5 MMPs as per their choice), e-Municipalities
<b>Integrated</b>	e-Business, Electronic Data Interchange, India Portal, Electronic Government Gateway, E-Courts, E-Office, E Procurement, Stock Exchanges

Figure 6. Tele-density in India - Growth

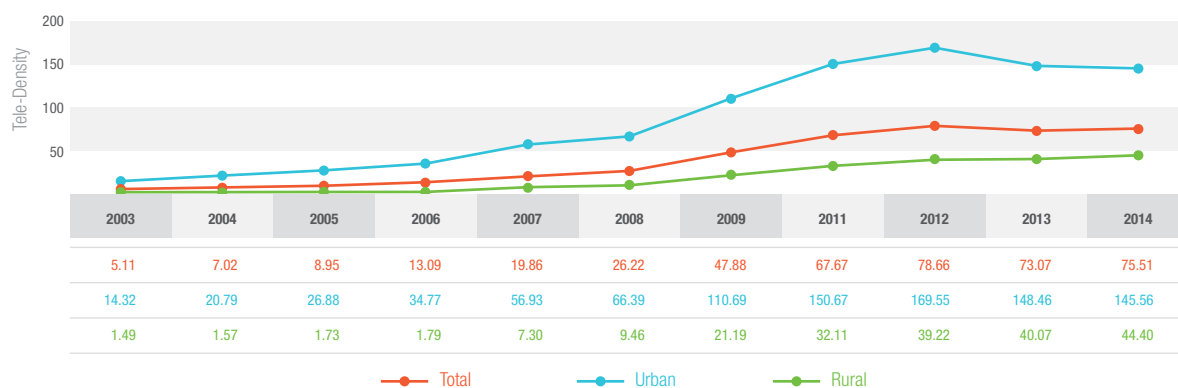

Common Service Centres are equipped with Internet connectivity, ICT infrastructure and applications as required making the centres self-reliant in providing service to citizens. Notwithstanding its progress in the area related to readiness, progress of the Plan has been critically influenced by the Indian policy. One of the critical gaps the policy has encouraged is the rural-urban tele-density as presented in figure 6. It indicates that the Indian scenario is still challenged by the rural-urban divide in the context of telecommunication infrastructure.

In figure 7, the status of network readiness in India is presented, which verifies that Indian policies are far from providing adequate ambience for citizen-centred services. Despite many shortfalls, affordability in accessing ICT enabled services has been very encouraging in India. However, the most challenging issues that hinder readiness include a poor political and regulatory environment; individual usage, infrastructure and digital content; and social impacts. Despite all these challenges India has shown encouraging impacts on government usage, skills, and business usage of ICT. Therefore, India needs to nurture an enabling political and regulatory environment to foster its e-readiness.

### Systems Deployment – Uptake and Availability

As presented, in table 3, the e-Governance Plan identified various mission mode projects for implementation. Today, almost all state governments have progressed in deploying websites for citizen-centric services, created state data centres, and automated various processes of governments including document management systems through SWANs. As regards national mode projects, the central government has also deployed web-enabled services for all ministries and implemented strategies for setting up of infrastructure for Internet, communication systems and networks (wire and wireless), application and services. While policy-level interventions like the National Telecommunication Policy - 1994, 1999 and 2012, and broadband policy 2000 are in force, various applications for G2C, G2B, and B2C categories are deployed.

### Impacts

Impacts of the Plan are multidimensional and have been mostly rural-centric. The first dimension relates to establishment of ICT infrastructure

under the public private participation model. A village level entrepreneur in a group of villages is seen as a service provider of the central government. This infrastructure is supported by the central and state governments in terms of extending Internet and providing online web-based services. The

Figure 7. Network Readiness Index- India (Bennat et al., 2014)

	Rank (out of 148)	Value (1-7)
<b>Networked Readiness Index 2014</b> .....	<b>83</b> .....	<b>3.8</b>
Networked Readiness Index 2013 (out of 144) .....	68 .....	3.9
<b>A. Environment subindex</b> .....	<b>91</b> .....	<b>3.8</b>
1st pillar: Political and regulatory environment .....	73 .....	3.6
2nd pillar: Business and innovation environment .....	103 .....	3.9
<b>B. Readiness subindex</b> .....	<b>85</b> .....	<b>4.6</b>
3rd pillar: Infrastructure and digital content .....	119 .....	2.7
4th pillar: Affordability .....	1 .....	7.0
5th pillar: Skills .....	101 .....	4.0
<b>C. Usage subindex</b> .....	<b>91</b> .....	<b>3.4</b>
6th pillar: Individual usage .....	121 .....	2.1
7th pillar: Business usage .....	51 .....	3.8
8th pillar: Government usage .....	41 .....	4.5
<b>D. Impact subindex</b> .....	<b>60</b> .....	<b>3.6</b>
9th pillar: Economic impacts .....	50 .....	3.5
10th pillar: Social impacts .....	73 .....	3.7

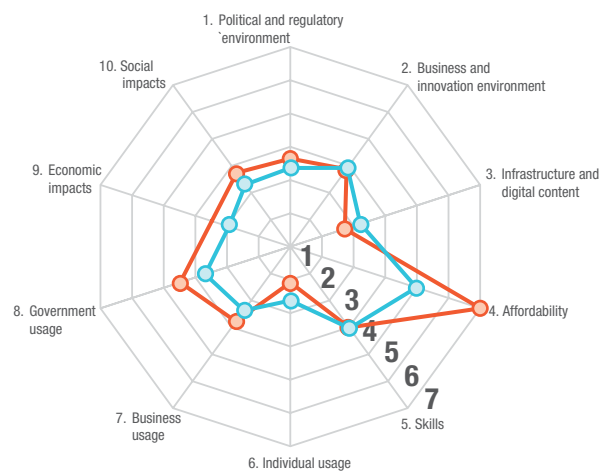



THE GOVERNMENT ALSO RECOGNIZED THAT  
- GIVEN THE SOCIAL, ECONOMIC, CULTURAL  
AND DEMOGRAPHIC DIVERSITY IN THE NATION  
- ICT COULD SUPPORT NETWORKING AMONG  
AGENCIES INVOLVED IN DEVELOPMENT, THEREBY  
RENDERING TRANSPARENT SERVICES AND  
REDUCING THE NEED FOR INTERMEDIARIES.



second dimension is the motive behind rendering e-services on demand in a village. This has led to infusion of trustworthiness of government systems among the locals who need not go too far to meet government officials for availing G2C services. Besides, many other services including B2C are being availed through this centre. The third most important dimension of this e-Governance Plan is the awareness among citizens on this transformation; that is acceptance of digital interfaces, e-collaboration and e-participation. However, outreach of this plan has been sporadic due to a strategic disconnect among ministries, state governments and channelling agencies.

### Opportunities and challenges facing NeGP

The National e-Governance Plan aimed to transform all services - including G2C, G2B, B2B and B2C - with convergence to spur growth and development, and by bringing in SMART e-governance systems. Various mission mode projects were planned for this purpose. The priority of the e-Governance Plan was to channel G2C services through Common Service Centres operated by village entrepreneurs in order to gain the trust of citizens in their government and thus the entrepreneurs would piggyback on this trust to operate the centres as a strategic business unit and make the business viable. Similarly, Service Centre Agencies which invested in the plan were expected to make their investment viable through transaction fees for revenue streams earned by village entrepreneurs. The most important premise for this viable plan was that all the citizens would transact with village entrepreneurs and receive G2C, B2C services at a fee determined by the central government. It meant that responsibility for channelling all the services through village entrepreneurs would lie with the central and state governments.

### Opportunities

By 2014, eight years after commencement of the e-Governance Plan its results were mixed. While many Service Centre Agencies withdrew from the plan citing unviable business for them, there are some like Sahaj e-Village Limited who still struggle to manage their business by making relentless efforts to network with government agencies, and deal with public and private sector channel services through village entrepreneurs. In many cases, village entrepreneurs have earned the respect and trust of citizens. Many urban centres have shown good

and viable business sense. Many state governments have channelled services and have been champions. Many mission mode projects at the central and state levels are being implemented with less attention to their integration through schemes like India Portal, the National e-Governance Services Delivery Gateway. Electronic data interchange and e-procurement are operational.

In figure 8, the status of mission mode projects are presented. All these, have created opportunities for all agencies in the e-governance supply chain to make use of this infrastructure. The scenario may change in favour of the e-Governance Plan for effective citizen engagements if all the mission mode projects are implemented as per the timelines, and with quality.

It is also pertinent to observe that while central mission mode projects are being implemented with due attention, states are yet to imbibe this strategy for extending services to citizens. In Indian, the role of state governments is important since these entities are close to the access layer of e-governance and near to the citizens. As regard municipalities, districts and other urban-centric e-governance services, the e-Governance Plan has been lagging in its schedule. Roll out of services at the central level has provided the desired learning for the state governments to carry on with their mandates and implement them in rural and urban areas for effective e-governance. The status of the

Figure 8. Implementation of MMPs in India, (INDG, 2014)

### Status of MMPs

Central-11	State-13	Integrated-7
Banking*	Land Rec./NLRMP	India Portal
Insurance*	Transport	NSDG
Income Tax	e-District	CSC
Central Excise	Commercial Taxes	e-Courts
MCA 21	Treasuries	EDI
Pensions	Municipalities	e-Procurement
Passport	Agriculture	e-Biz
e-office	Police-CCTNS	
National ID/UID	PDS	
Immigration/Visa	e-Panchayat	
e-Posts	Employment Exch.	
	Health	
	Education	

### Legend

- MMPs Delivering Services (\*Industry Initiative)
- MMPs Delivering Services partially
- Design & Development
- Under implementation
- DPR Stage

Figure 9. Implementation of MMPs in States in India, (INDG, 2014)

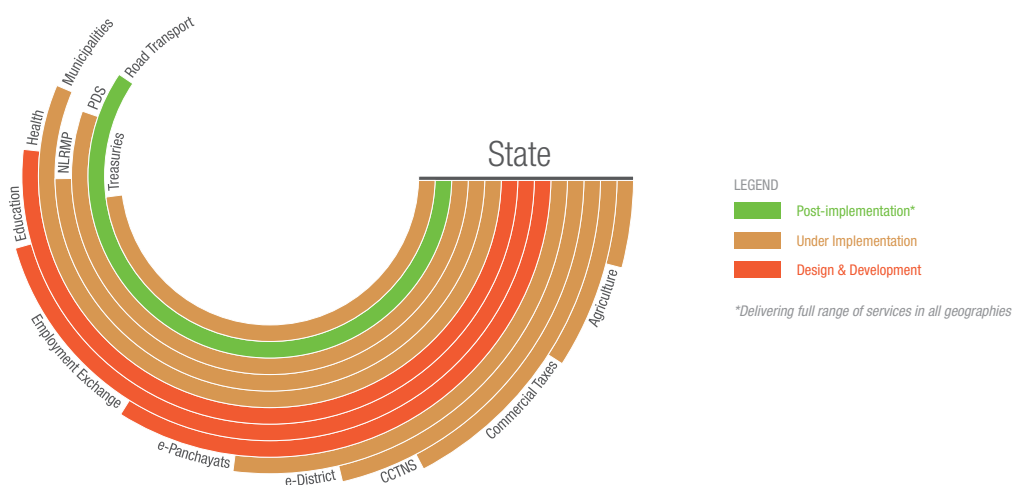

state-level plan is presented in figure 9. It may be seen that all services except road transport are at different stages of implementation by states.

It may be noted that Common Service Centres, although they are service centres with a focus on rural e-governance, have provided insights to implement urban e-governance interfaces with citizens. This is an opportunity for the planners to provide rural-urban continuum in rendering Service oriented Architecture based citizen interfaces and scale up the services through Common Service Centres.

## Challenges

Implementation of the National e-Governance Plan faced enormous challenges. Though its conceptualization and implementation have been well articulated, the Plan has been challenged by political divides of a federal nature. The political divide is part of Indian governance since every state has its own legislation and is a body of elected representatives. These representatives need not be from the same political party that governs central legislation. This divide provides scope for any national intervention to be made ineffective at the state level. Under this federal structure every state is expected to have state level Mission Mode Projects apart from the central level Mission Mode Projects. However, each state having its democratic, political and demographic priorities, it either slows down the implementation of the plan or ignores.

In figure 9 it is evident that state governments are yet to fully embrace the Plan and service deliveries. This has led to overruns in time, resource allocations and utilizations. In most of the cases, the mission mode projects have faced poor and isolated process re-engineering, leading to inadequate service orientation. However, some projects, including the Ministry of Company Affairs (MCA-21), Income Tax online, e-Passport Services, core banking solutions, online DMAT stock services and Indian Railways; online Passenger Services have showcased best practices. Yet learning from these best practices has been very limited with respect to convergence and integration.

Understanding challenges to the e-Governance Plan implementation needs careful consideration of its deliverables in three layers of governance structure that India pursues; and they are network, distribution and access as presented in table 2. The network layer of the Plan has been grossly inadequate in terms of e-readiness and its supporting policy formulation, spectrum allocation, poor coordination and networking with SWANs and central ministries, and in creating protocol and standards for the seamless integration of citizen-orientated services. Islands of web-enabled citizen interfaces exist in almost all governments, and ministries at the national and state government levels. However, there is no timescale for the deployment of mission mode projects and their integrated variety as envisaged. Performance of the e-Governance Plan in the distribution layer has been limited due to poor preparedness in the network layer.

However, the National Informatics Centre, an agency supported by central government, has been successful in liaising with state and central governments, and today online multimedia networks interfaces are available on demand for government departments. E-procurement services, though, have been available as a standard process for all national and state government departments. State Designated and Service Centre agencies, Special Purpose Vehicles, and State Data Centres are yet to be well networked for rendering online and integrated services. Access layer of the National e-Governance Plan, which is dependent on the successful deployment of services in network and distribution layers, has been seriously challenged. Inadequacy in rendering citizen services; inability to create on-demand service portfolios; and channelling orchestrated services as per Service oriented Architectures as well as information asymmetry among citizens are still prevalent in the Indian context despite the e-Governance Plan's interventions.

## NEGP and Rural-Urban Continuum

The National e-Governance Plan envisaged providing support to the rural-urban continuum for good and SMART governance. It is noted



that all the mission mode projects, categorized as state, central and integrated, are envisaged to be independent of rural urban geographic limitations. This two-pronged approach envisaged two benefits: the first was to ensure uptake in services in urban areas and the second, enhancing e-readiness in rural areas and creating opportunities for citizens to gain access to the e-Governance Plan. It envisaged that rural migrants to urban areas can pursue better quality of life, and urban entities that look for business opportunities in rural areas can also gain in the process.

The initial portfolio of e-services focussed on G2C, B2C, B2B and even C2C services, and were also mandated to roll out these services through Common Service Centres. Panchayat Raj Institutions, Peri-urban areas and municipalities also came under the jurisdiction of the e-Governance Plan because of India's matured governance and institutional frameworks. The Plan envisaged that it would be feasible for the rural sector to make use of knowledge resources, best services and processes available in the urban sectors like health and education; as well as establish linkages with urban India for an effective supply chain for augmenting local primary production and livelihood systems in rural areas. The Plan also considered user-centred design related challenges that rural e-governance services would face. The Plan also designed for institutional frameworks with village level entrepreneur-supported interfaces where each entrepreneur belongs to the local community.

The village entrepreneur in the National e-Governance Plan is expected to be the link between rural residents and the service provisioning agencies, and needs to inculcate the desired trustworthiness by initially rendering G2C services followed by B2C services, including inputs for supporting primary production systems in villages. As regards the rural continuum with the urban set up, the village entrepreneur is expected to provide information symmetry-related services to migrants, students, job seekers, citizens seeking health and medical attention, and exploring income generation opportunities. The entrepreneurs are also envisaged to support e-collaboration and e-participation services at the Common Service Centres to enable urban agencies to innovate products and services through market research inputs. Because village entrepreneur possesses local knowledge through intensive and regular engagement with residents, it is thought they are, best placed to provide services with active support of NeGP agencies.

### Role of NEGP in influencing Urban Policy Design

The National e-Governance Plan, with the focus to introduce e-services to villages, has brought in revolutionary changes in digital networks. The kiosk-driven approach has been popularized through this process. In every panchayat (rural area), small town, and even in urban area, kiosk-based services are now available. The e-Governance Plan, with its backend networks with all the states (SWANs), has provided the impetus for digital networks among all departments (centre and states), municipalities and panchayats. Overall, mission mode projects at the central and state levels have showcased the potential for urban policy designs to include kiosk-centric services with a strong backend service network.

The e-Governance Plan's unique "Hub and Spoke" service model has the potential to showcase best practices in e-governance spectrum and it has all the qualifiers for replication in other countries with a rural-urban continuum focus. The Plan's astounding contributions to digital India is its successful encouragement of rural residents to accept digital transformation and receive online services at their doorsteps.

Today, citizens interact with government and elected representatives through video conferencing and participate in the decision-making process. Such facilities are now available in rural areas and municipalities. This has been possible due to increased connectivity and better bandwidth management in the backend. Local governments like panchayat, municipalities and governing bodies in urban areas have been able to keep track of citizen demands for their livelihoods and businesses. This has enabled the planners to provide proactively designed citizen interfaces and services. The Plan today has enhanced transparency in all the local governments (like e-tendering, e-procurement, e-business). This is huge improvement in Indian context and could be benchmarked for other countries.

### Case of SAHAJ e-village limited

Sahaj e-Village Limited, as a service centre agency, contributes to the National e-Governance Plan. SeVL has been mandated to roll out 28,000 plus Common Service Centres across six states: Uttar Pradesh, Bihar, Odisha, Assam, Tamil Nadu, and West Bengal in 107 districts. So far, SeVL has rolled out 26,066 of these centres. Each is owned and managed by a village entrepreneur, who is from the same locality and is selected through a rigorous process. Common Service Centres are controlled by State teams through district regional coordination centres.

The organization manages these common service centres through a centralized data facility as presented in figure 10. Major services rendered include collection of electricity bills from consumers of various state-level electricity distribution companies, reservation services of Indian Railways, e-learning with Microsoft tools, facilitation of insurance services and many other amenities co-created with village entrepreneurs. Every Common Service Centre is connected to Sahaj e-Village Limited's Level 3 data centre in Kolkata. SeVL has been investing heavily on information technology infrastructure and connectivity. It has three portals, balanced by world class enterprise resource planning software at the backend, and well supported by Level 3 Data Centre. Village entrepreneurs are connected to the SeVL portal through broadband. SeVL has the capabilities for innovating services and deploying them online for the benefits of citizens. Such services rendered are presented in figure 11.

Sahaj e-Village Limited has identified many services that support the rural-urban continuum. Most notably, skill development and e-learning services; training on Desk Top Publishing through off-line mode, providing e-governance services as made available to the Common Service Centres, and Service Centre Agencies through State Designated Agencies, and the Special Purpose Vehicle provides the ambience that could be helpful in peri-urban and urban environments.

Figure 10. E-Governance Infrastructure of SeVL(Misra and Panigrahi, 2013)

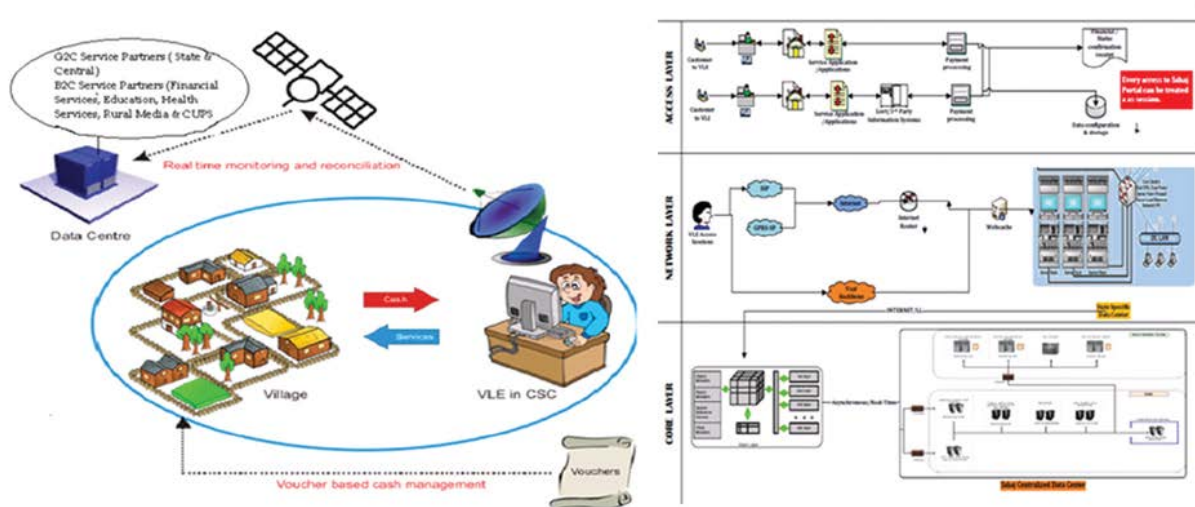

### SeVL’s Approach for Rural-Urban Continuum

Having created an environment for village entrepreneurs, channelling various services such as G2C and B2C through the e-Governance Plan and its own innovations, SeVL recognized that success in isolation and in specific areas would not provide the business viability for village entrepreneurs. Additionally, SeVL also recognized that services envisaged under the e-Governance Plan could, potentially, be replicated in urban areas. The company understood that population density in rural India was around 382 per square kilometre with around 1,300 residents concentrated in a village, whereas in the urban context population density was around 11,000 per square kilometre. Despite this disparity, common services as enumerated in table 1 are relevant for replication. Hence, SeVL looked for a market with significant numbers of people who could avail common citizen-centric services, which often contribute to the rural-urban continuum. Today, rural Common Service Centres under SeVL are equipped for extending services as presented in table 4.

**Table 4** Service Rendered by SeVL Supported Common Service Centres

CATEGORIES	SERVICES
e-Utilities	a. Electricity Bill Payment b. Telephone Bill payment c. Water Bill Payment
E-Citizen Services (G2C)	a. Birth Certificate b. Death Certificate c. Caste certificate d. PAN Card e. Driving License f. Commercial Tax Payment g. Other G2C Services
e Learning	a. Computer Education
Other B2C Services	Facilitation of premium collection for Life Insurance & General Insurance policies

Figure 11. SeVL Services (Misra and Panigrahi, 2013)

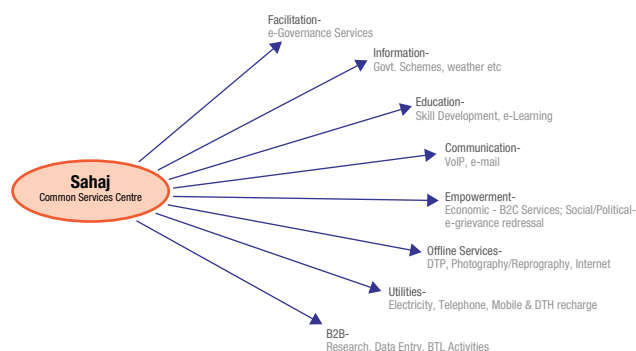

SeVL is convinced that all the stages - A through E - listed in table 1 and figure 5 have the potential to access the services in urban centres with the categories presented in table 5. With a view to expanding its presence, SeVL has few urban common services centres extending facilities as detailed in table 5. Successful replication services in urban centres include e-learning, e-utilities, Net banking, e-pension, e-public distribution, e-citizen services and some of B2C amenities like e-insurance.

### Success Factors of SeVL

Sahaj e-Village Limited has been successful in scaling up its Common Service Centre networks and enhancing its scope for channelling e-services across the e-governance spectrum. Its unique success factor is related to providing unifying services to its village entrepreneurs through its data centre that houses a centralized database and web 2.0 enabled village level entrepreneur interfaces for better online social

networks, online secured transactions and, most importantly, meeting government audit requirements online. Another success factor for SeVL is its innovative workforce that interfaces for competence enhancements of village entrepreneurs and increasing citizen interfaces. Many innovative services are channelled through the Village Level Entrepreneur network seamlessly and one of the most successful interventions is to channel e-learning services.

## Recommendations and future research directions

This chapter presented an e-governance scenario and discussed the opportunities, challenges in implementing India's National e-Governance Plan. As per the proposed frameworks, the study revealed scope for improvement in many areas and especially in supporting the rural-urban continuum. It is also discussed in the chapter that the Plan, though it is severely challenged by digital divides, provides scope for e-governance interventions to foster citizen engagements. The central government has announced the National e-Government Plan 2.0 (e-Kranti) with focus on inclusive governance, more citizen-centred services, and the importance of integrated mission mode projects with global information system interfaces. It is, therefore, imperative to recommend that all the frameworks proposed in this chapter are relevant for the National e-Governance Plan v.2.0.

The first recommendation is to note that the Plan is still grappling with digital divides and poor e-readiness, which needs proactive audits through planned performance measurements based on these frameworks. Moreover, digital divides need to be dealt with as a priority and Service Centre Agencies could play a vital role in supporting this cause. Rural e-governance provisions, through Common Service Centres, provided the insights to promote village entrepreneurs. This learning would help in institutionalizing e-governance service networks in urban, municipalities and peri-urban areas. This would ensure a better rural-urban continuum paradigm. In order to accomplish this, the third recommendation is to enforce convergence in infrastructure, services and institutions. The Common Service Centre has showcased this as a common delivery facility, which is important for the urban set up. E-participation and e-collaboration are major impediments of the National e-Governance Plan, and these two issues without information and communication technology interventions are well pursued in the rural set up through social cohesiveness. Therefore, the fourth recommendation is to promote social and institutional arrangements in the urban e-governance environment to foster e-collaboration and e-participation. The fifth recommendation is finding disruptive technologies, tools and applications for the rural-urban continuum, and these must be supported by web 2.0 features and service orientated architecture.

In the Indian context, none of the National e-Governance Plan services are totally disruptive, thus there is scope for improvement. Web 2.0 and service orientated architectural principles advocate user

centeredness. Therefore, they need to learn from the rural social set up. The sixth recommendation is for role clarity and accountability among e-Governance Plan constituents. All such constituents are yet to support each other and thereby add value in rendering e-services.

The Special Purpose Vehicle has been drifting away from its role as coordinator of Service Centre Agencies, state and central governments, and channel back-end integrated support to the Service Centre Agencies. The Special Purpose Vehicle has been ineffective in deploying mission mode projects as envisaged. Service Centre Agencies are struggling to provide assistances because of the lack of coordination that the Special Purpose Vehicle is expected to ensure so that village entrepreneurs run the Common Service Centres as a strategic business unit.

Lack of adequate G2C services in Common Service Centres has adversely affected trustworthiness in village entrepreneurs among citizens as the public consider them as a commercial entity looking for business. This has cascading effects on introducing innovative services through these entrepreneurs that Service Centre Agencies plan as per the National e-Governance Plan mandate.

The future research direction is two-fold for this study. First, the National e-Governance Plan has provided insights into policy paralyzes, poor project management and planning; and has envisaged most of the services to be supply-driven. Thus, one of the important research agendas is to benchmark the e-Governance Plan under web 2.0 and service-orientated architecture principles, and generate measurements standards for understanding the agents for a successful e-Governance Plan. The second important research direction is to relate the e-Governance Plan's interventions to sustainable development. While sustainable development and e-governance paradigms are well researched, their contributions to the rural-urban continuum need sustained research.

## Conclusion

This chapter focused on India's National e-Governance Plan, its supporting environment and the process through which it is being implemented. It also presented the digital divides with which India is still grappling, and the National e-Governance Plan v.2.0 India is trying to implement with more focus on citizen-centredness, and mission mode projects having integrated e-services.

The chapter also focused on the rural-urban continuum and suggested that any e-governance plan should ignore this phenomenon. The chapter suggested ways to create an enabling environment for better rural urban interfaces. In order to accomplish these tasks, the chapter discussed various recommendations and suggested future directions to make e-governance plans more citizen-centred.

## References

- Braun, J. V., (2007), Rural-Urban Linkages for Growth, Employment, and Poverty Reduction,
- Beñat Bilbao-Osorio, Dutta, S., and Larvin, B. (Ed.), (2014), The Global Information Technology Report 2014, Rewards and Risks of Big Data, INSEAD, France
- Chang, A., and Kannan, P. K., (2008), Leveraging Web 2.0 in Government, E-Government/technology series, IBM Center for The Business of Government. Available from <http://www.businessofgovernment.org/pdfs/ChangReport2.pdf> accessed on 20/09/2013.
- Dewey, R., (1960), The rural–urban continuum: Real but relatively unimportant, *American Journal of*
- DIT, (2011), E-district Guidelines for National Rollout, Department of Information Technology (DIT), Government of India, New Delhi.
- DIT, (2014). Available from <http://www.indg.in/e-governance/e-governance/egov-prod>
- Eggers, W. (2005), *Government 2.0: Using Technology to Improve Education, Cut Red Tape, Reduce Gridlock and Enhance Democracy*, New York: Rowman and Littlefield Publishers.
- European Union (EU), (2007), "Inclusive e-Government: Survey of status and baseline activities", European Commission, DG Information Society and Media, e-Government unit, December, Fifth International Conference on the Ethiopian Economy, June 7–9, United Nations Conference Centre, Addis Ababa
- Heeks, Richard and Alemayehu, Molla (2009) "Impact Assessment of ICT-for-Development Projects: A Compendium of Approaches", Working Paper 36, Institute for Development, Policy and Management (IDPM), University of Manchester.
- INDG, India Development Gateway. 2014. Available from <http://www.indg.in/e-governance/e-governance/egov-prod> accessed on 12 August 2014
- Mehdi, K., (2005), *Practicing E-Government -A Global Perspective*, Idea Group Publishing, London, ISBN: 1-59140-637-4.
- Misra, H. K., (2010a), Role of Information Systems Architecture in E-Governance: The Case of MGNREGS in India. The 4th International Conference on Theory and Practice of Electronic Governance (ICEGOV2010), Beijing, China, 25 - 28 October 2010. Published in the Proceedings of ACM.
- Misra, H.K., (2010b), Understanding SOA Perspective of e-Governance in Indian Context: Case Based Study, Book Chapter, Book Title "User Interfaces", ISBN no. 978-953-307-084-1, published by IN-TECH, Vienna.
- Misra, H. K., (2013), Emerging Role of Systems Thinking Oriented E-Governance for Supporting MDGs: Learning in Indian Context, The 7th International Conference on Theory and Practice of Electronic Governance (ICEGOV2013), Seoul, South Korea, 22-25 October. Published in the Proceedings of ACM.
- Misra, H. K., and Panigrahi, Sanjay, (2013), Mediating Rural Citizen Participation in e-Governance: Case of Sahaj e-Village Limited, IAMCR - 2013, Dublin City University (DCU), Dublin, Ireland, 25-29 June.
- Misra, H. K., and Panigrahi, Sanjay, (2014), Citizen Engagements and Participation in Indian e-Governance with an Architectural Perspective: Case of Sahaj e-Village, CeDEM - 2014, Krems University, Krems, Austria, 21-23 May.
- O'Reilly, T., "What Is Web 2.0," Retrieved from <http://www.oreillynet.com/pub/a/oreilly/tim/news/2005/09/30/what-is-web-20.html> accessed on 20/09/2013.
- OECD, (2003) *Promise and Problems of E-Democracy: Challenges of Online Citizen Engagement*. Accessed 24 February 2014. Available from <http://www.oecd.org/governance/public-innovation/35176328.pdf>
- Pahl, R. E., (1966). The rural-urban continuum, *SociologiaRuralis*, pp. 299–327.
- SESRIC, (2010), *E-Government Development and E-Participation the Performance of the OIC Member Countries*, Statistical, Economic and Social Research and Training Centre for Islamic Countries, (SESRIC), Ankara.
- United Nations, (2010). *The Global Partnership for Development at a Critical Juncture. MDG Gap Taskforce Report*, United Nations, New York.
- United Nations, (2011.) *Millennium Development Goals Report.*, New York.
- West, D.M., (2008), *Improving Technology Utilization in Electronic Government around the World, 2008*, Governance Studies, Brookings Institution, Washington, DC

## Endnotes

1. Up Time is defined as the time period during which the computer remains in operation for transactions with citizen. This is one of the performance indicators of the VLE and SCA.



# Part 3

## TOOLS AND METHODOLOGIES FOR COMMUNICATION, VISUALISATION AND MONITORING

A girl smiles while talking on a cell phone during a street parade celebrating the anniversary of a local street band. May 6, 2012 in Niterói, Brazil. © Shutterstock/Larissa Pereira





# Fuzzy Cognitive Maps for Urban Policy Design in Developing Countries

○ Haris Neophytou

Interfusion Services Ltd, Lemesos, Cyprus

○ Constantinos Stylianou

Department of Computer Science, University of Cyprus, Lefkosia, Cyprus

## Abstract ○

This paper presents an initial investigation of the potential of fuzzy cognitive maps as a modelling and simulation instrument for urban policy design in developing countries. Several recent approaches that use fuzzy cognitive maps modelling have been proposed aiming to help decision makers in a number of policy domains by gathering stakeholder opinions, as well as by simulating the impact of policy scenarios. Preliminary results, conducted partially in the context

of the FUPOL project in selected urban policy domains, provide positive indications that fuzzy cognitive maps have the potential to be a suitable method for preparing for urban evolution, and that developing countries are ideal candidates for embracing and benefiting from such a policy simulation approach. However, there is still a need to expose policy decision makers in developing countries to its practicality and simplicity as a policy learning and simulation tool.

### Keywords:

fuzzy cognitive maps, intelligent tools, policy modelling, policy simulation.



## Introduction

Urban policy design is one of the most challenging problems facing policy decision makers in developing countries because rapid urbanization has increased the need for better governance of towns and cities. There are a number of different policy areas that need attention – including, among others, planning, housing and slum upgrading, land, energy and climate change, reconstruction and resilience, as well as water and sanitation – all of which add to the complexities of modern-day policy decision-making.

It is critical for decision makers to be able to identify how different stakeholders view a particular problem in order to adequately collect opinions and beliefs of people and organizations involved or affected by a policy, as well as the knowledge and expertise of specialists in a particular domain. Only once these views are collected can decision makers be able to assess the impact of a policy on the stakeholders. For example, in housing policymaking, it is important for local authorities to gather the opinions of different types of stakeholders such as home owners, representatives of the homeless and construction workers whose opinions may or may not be in conflict. Following this, decision makers must evaluate how a new policy or change of an existing one will affect these different stakeholders, and then decide whether to adopt or reject the policy.

For governments and local authorities, particularly in developing countries, it is necessary for them to be equipped with the right tools in order to tackle the demands of the policymaking process and to be able to improve the quality of policies in terms of effectivity and acceptability. Support from information and communications technology has provided some progress in improving governance, especially in the form of intelligent techniques. Fuzzy cognitive maps are one such technique, which rely on the use of expert knowledge to help model the current state of a problem and simulate the interaction of the factors within the problem to predict future states. Specifically for urban policymaking, such maps can be used to represent various policy domains and predict the impact of different policies and the reaction of citizens in terms of effectiveness and acceptability. Due to their ease of use and simplicity, they are considered a powerful and reliable decision support tool capable of performing “what-if” scenario analysis and are also suitable to consolidate the opinions of stakeholders and citizens.

## Background

Axelrod (1976) introduced cognitive maps as a way to help decision makers represent complex sociopolitical problems by capturing and organizing the knowledge of experts in the form of a “mental model” depicted visually by an acyclic directed graph composed of nodes and edges. The nodes symbolize the concepts constituting a problem (possible variables, states, events or actions) as perceived by an expert. Concepts can have either a positive or negative presence in the problem, and are expressed as quantities (e.g., city population) or as qualities (e.g., satisfaction of citizens). The edges denote the cause-effect relationships between these concepts, again as recognized by an expert. A causal relationship can have either an excitatory (positive) causality, meaning that an increase in strength of the cause concept leads to an increase in

the strength of the effect concept, or an inhibitory (negative) causality, meaning that an increase in strength of the cause concept leads to a decrease in the strength of the effect concept. Figure 1 shows an example of a cognitive map representing an expert’s mental model of the factors present in the domain of public health and their relationships (Maruyama, 1963). As can be seen in the diagram, expert knowledge and beliefs have been systemized into a cognitive map consisting of quantitative and qualitative concepts that influence and are influenced by other concepts.

Figure 1. Public Health Cognitive Map (Maruyama, 1963).

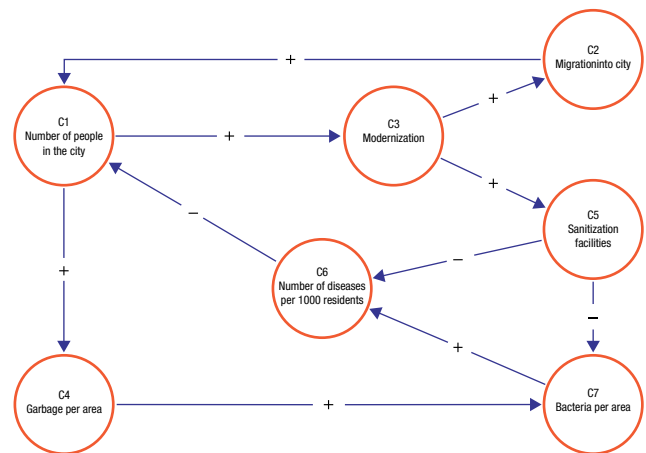

As an extension of cognitive maps, Kosko (1986) proposed fuzzy cognitive maps by combining fuzzy logic theory (Zadeh, 1965) with artificial neural networks (McCulloch and Pitts, 1943) as a way to allow decision makers to simulate the dynamic behaviour of concepts as they interact in a cognitive map. Essentially, the mental model is initialized with values to reflect the current state of the problem in fuzzy terms. Specifically, concepts in a fuzzy cognitive map are assigned an activation level that determines the degree of presence; concepts can now have either a strong or weak presence in a problem, whether



FOR GOVERNMENTS AND LOCAL AUTHORITIES, PARTICULARLY IN DEVELOPING COUNTRIES, IT IS NECESSARY FOR THEM TO BE EQUIPPED WITH THE RIGHT TOOLS IN ORDER TO TACKLE THE DEMANDS OF THE POLICYMAKING PROCESS AND TO BE ABLE TO IMPROVE THE QUALITY OF POLICIES IN TERMS OF EFFECTIVITY AND ACCEPTABILITY.



acting as either a positive or negative factor. Each concept is fuzzified by creating overlapping intervals associated with different interpretations. For example, experts may divide the concept of modernization into three overlapping intervals: below standard, basic and high, with each interval defined by a set of bounding values. If an expert determines that the current situation regarding the modernization of a city is below standard, then the activation level assigned to the concept will be within the bounds of the corresponding interval. Similarly, causal relationships are assigned a weight value that determines the strength of the connections; causal relationships can now denote either a strong or weak influence between concepts, whether the connection is excitatory or inhibitory. Figure 2 depicts a fuzzy cognitive map using the concepts and causal relationships comprising the mental model of the public health domain. With such structured representation of knowledge, decision makers can reconstruct the reasoning behind the behaviour of a specific variable in a problem (e.g., the concept of modernization) or form a workable explanation of the cause of an event or action in a problem (e.g., the concept of migration into city) or make decisions in the context of a problem (e.g., the concept of sanitization facilities).

Figure 2. Public Health Fuzzy Cognitive Map.

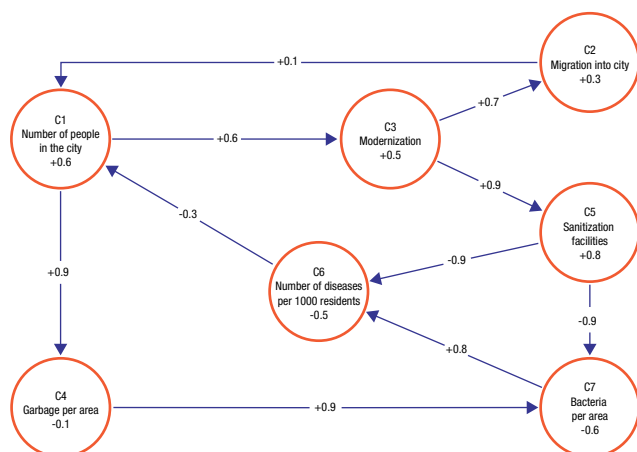

Construction of a fuzzy cognitive map relies on expert knowledge. Decision makers, therefore, can consult a number of domain experts in order to identify the concepts present in a problem domain and the connections between these concepts, and then have the experts initialize the model based on what they believe best reflects the current state of the problem. Additionally, decision makers can use existing scientific literature to extract the concepts and causal relationships. Alternatively, involved stakeholders can be called upon to construct and initialize a fuzzy cognitive map based on their own points of view. Decision makers can then consolidate individual maps into one for each group of stakeholders to get a better understanding of how different groups of people store and process knowledge, as well as to gain insight into how various actions and decisions are taken by groups of people with differing opinions.



IN GENERAL, FOR DEVELOPING CITIES AND REGIONS WHERE DROUGHT MITIGATION STRATEGIES ARE ABSENT, FUZZY COGNITIVE MAPS CAN PROVIDE VALUABLE ASSISTANCE TO DECISION MAKERS FOR FORMULATING AND EVALUATING THE IMPACT OF POLICIES, AND AVOID CONSEQUENCES SUCH AS FAMINE AND DEHYDRATION, MIGRATION (HUMAN AND WILDLIFE), AS WELL AS SOCIAL UNREST.



Simulation of a fuzzy cognitive map aims to help decision makers assess the future state of a problem by conducting scenario analyses on the current state of a problem. The process involves allowing the concepts in the model to interact. In other words, the strengths (activation levels) of the concepts are iteratively changed based on the influence (weight values) each one receives from all other concepts with which it shares a connection. As iterations execute, the activation levels of concepts are updated leading to a final equilibrium state, where each concept's activation level reaches a fixed point. Less desirably, the activation levels sometimes may not converge at a fixed point, but instead oscillate either between a fixed-length range of values (exhibiting limit-cycle behaviour) or between a random-length (non-deterministic) range of values (exhibiting chaotic behaviour). For policy makers, specifically, they are able to evaluate the impact of a policy by altering the current state of a problem to reflect the changes brought on by the adoption of the policy. Then, by allowing the map to interact, the final state of the concepts will represent the effectiveness of the policy. Furthermore, if each group of stakeholders has a corresponding fuzzy cognitive map, then simulation will be able to assess the level of acceptability of a policy by each group of stakeholder individually, thus helping policy makers reach a more informed decision.

As a result of the increased use of such maps, a number of variations have been proposed over the years. Examples include certainty neuron fuzzy cognitive maps (Tsadiras and Margaritis, 1997); rule-based fuzzy cognitive maps (Carvalho and Tomé, 2004); genetically evolved certainty neuron fuzzy cognitive maps (Andreou, Mateou and Zombanakis, 2005); multilayered fuzzy cognitive maps (Mateou, Andreou and Stylianou, 2006); and belief degree distributed fuzzy cognitive maps (Mkrtychyan and Ruan, 2012).

### Applications of fuzzy cognitive maps

FCMs have been adopted in many application domains, particularly for complex social and political systems requiring an accurate representation of knowledge in order to assess the impact of changes to the current state of a problem and to forecast future states. In this section we review several approaches, which are believed to have the potential

to be applied in various urban policy domains and, consequently, to help decision makers in developing countries formulate and assess the impact of policies. In particular the focus is on the adoption of FCMs in water/sanitation and energy urban policy domains.

## Water and Sanitation

Many developing cities are struggling to cope with issues regarding water distribution and sanitation systems, especially as more people compete for resources due to rapid urbanization. According to UN-Habitat around 11 per cent of the world's population currently still lacks access to water from a safe and clean source. For Sub-Saharan Africa alone, this figure increases to over 40 per cent of its population. Furthermore, adequate sanitation systems are severely lacking, with roughly 2.6 billion people without access to toilets and other hygiene facilities. Consequently, high levels of waterborne diseases, pollution and contamination, which are the result of poor sanitation, inevitably cause an increase in health risks. UN-Habitat is currently running several programmes that prioritize safer water and sanitation systems focusing particularly on the urban poor. These programmes aim to support governments and local authorities through policymaking, as well as technically and financially.

Fuzzy cognitive maps can help governments and local authorities deal with these issues by modelling and simulating the impact of water and sanitation policies on urban development, in addition to be used as a means to gather opinions, beliefs and attitudes of citizens and stakeholders. These policies may concern regions suffering from physical water scarcity, such as Northern and Southern Africa, Northern China and Mexico, or places with economic water scarcity, like countries in Central and South America, Southeast Asia and Central Africa (UNESCO/WWAP, 2012).

Over the last decade, fuzzy cognitive maps have been used in a number of research works in this field. For example, they have been used in drought management to analyse and solve potential conflicts between the different perceptions of stakeholders (Giordano et al. 2005; Giordano and Vurro, 2010). In this case, the goal was to use the maps in order to help regional authorities and local municipalities in the Umbria Region of Central Italy to assess the level of acceptability of a drought management action among the parties, agencies and industries immediately affected, such as agriculture workers, tourism, as well as citizens. The first step involved eliciting the drought perceptions of these groups of stakeholders and structuring them into mental models consisting of what they believed were the important elements and interactions affecting drought in their environment. Figure 3 displays the cognitive map resulting from the elicitation of the perceptions of farmers.

The second step involved simulating scenarios to determine the degree to which particular policy management actions (wastewater reuse, provision of technical support to farmers, changes to agricultural practices, emergency planning) would be accepted. In general, for developing cities and regions where drought mitigation strategies are absent, fuzzy cognitive maps can provide valuable assistance to decision makers for formulating and evaluating the impact of policies, and avoid consequences such as famine and dehydration, migration (human and wildlife), as well as social unrest. Similarly, Moratiadou and Moran (2007) employed fuzzy cognitive maps to model public participation in the European Union Water Framework Directive for assessing strategies regarding sustainable management of water resources in Europe. Specifically, the aim was to gather public and stakeholder perceptions on the current state of water resource management in the Pinios River Basin in Central Greece, and then assess the impacts of certain policies in terms of acceptability by the public. Once all stakeholder perceptions

Figure 3. Cognitive map of Farmers' Association (Giordano and Vurro, 2012).

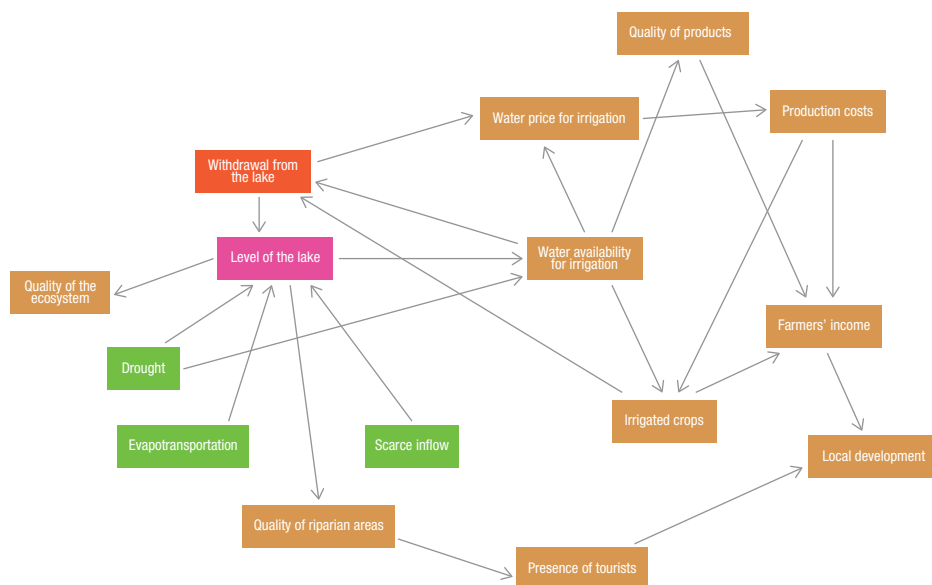
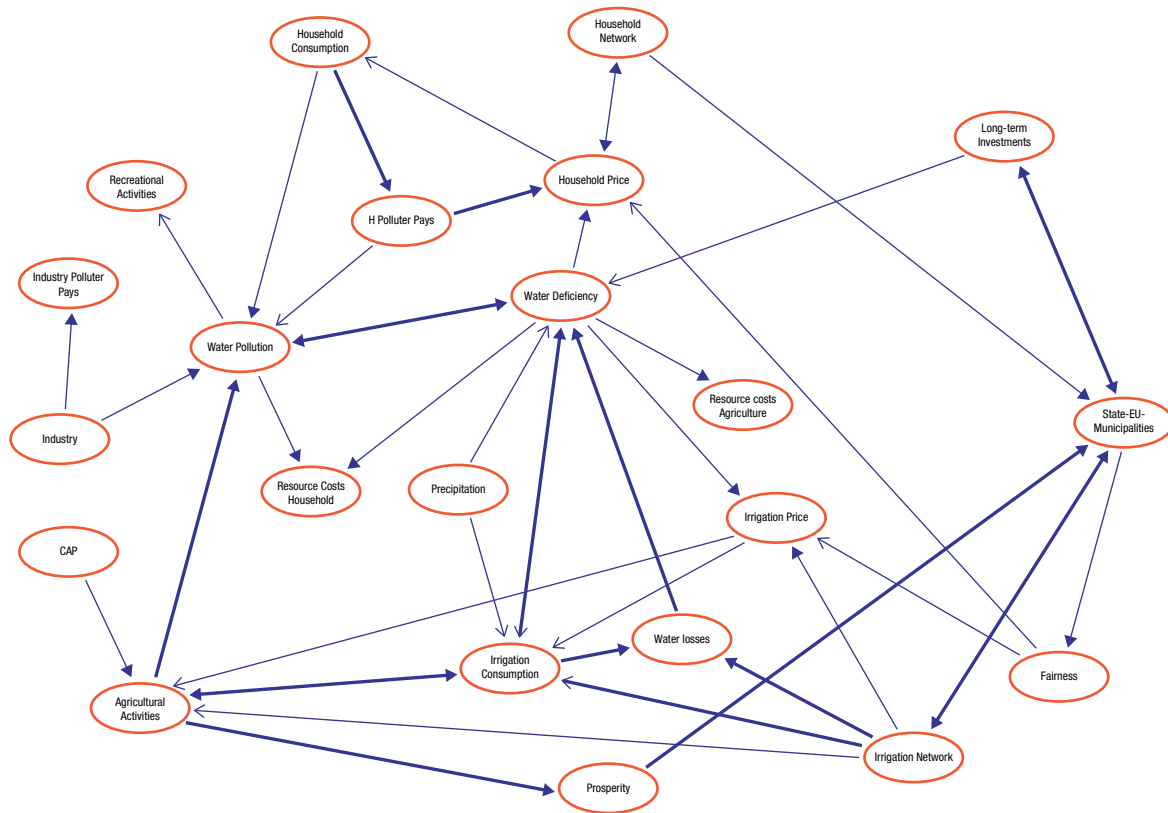

Figure 4. Social Current State Map (Mouratiadou and Moran, 2007).



were collected, they were consolidated into a unified social cognitive map (Figure 4). Using the cognitive map, several policies altering the current state were simulated in order to determine the social, economic and environmental impacts of the policies on the stakeholders. The policies concerned: (1) the increase in water supply through long-run water storage investments and expanding irrigation networks; (2) the application of full cost recovery and pollutant pays principle; and (3) the combination of different measures desirable to stakeholders.

Kafetzis, Roberts and Mouratiadou (2010) present another application of fuzzy cognitive maps for elicitation of stakeholders' perceptions, this time regarding water resource management and usage in the Maritza/Meric/Evros transboundary river between Bulgaria, Greece and Turkey. Here, the complexity of the problem being modelled increased due to the addition of political, historical and cultural issues, as well as environmental issues related to land use.

In general, developing countries can benefit from the use of fuzzy cognitive maps for water and sanitation in many ways in order to increase public participation and also to raise awareness regarding sustainable water resource management for sanitation, agriculture and food production, as well as for industries and as an energy source. Local authorities would be able to capture the perceptions of stakeholders in a model and evaluate the degree of acceptability of different policies through simulations.

## Energy

Energy is another important challenge that developing countries are currently facing. The issues regarding energy include resource generation, storage and distribution, and consumption and use. Primarily, the focus for developing countries is on planning for sustainable and renewable energy, which also links with combating climate change.

Amer, Jetter and Daim (2011) proposed using the modelling and simulation capabilities of fuzzy cognitive maps as a way to construct scenarios for wind energy deployment in Pakistan. At present, Pakistan's main source of renewable energy is generated by hydroelectricity. However, due to energy and power shortages, the government has investigated the potential of other renewable energy sources such as solar and wind. With the help of two experts, a fuzzy cognitive map was created (Figure 5) to represent the current state of the problem.

Once the model was constructed, three scenarios were examined (economic growth, economic growth and favourable government policies, growing environmental concerns) through simulation, in order to understand the effects of changes to the current situation, such as an increase in electricity demand. Using the results of simulations, the authors then prepared a technology roadmap suggesting to the policy decision makers the necessary strategic and technology planning required for the successful deployment of wind energy in Pakistan.

Figure 5. Combined Causal Map/Fuzzy Cognitive Map for Deployment of Wind Energy (Amer, Jetter and Dain, 2011).

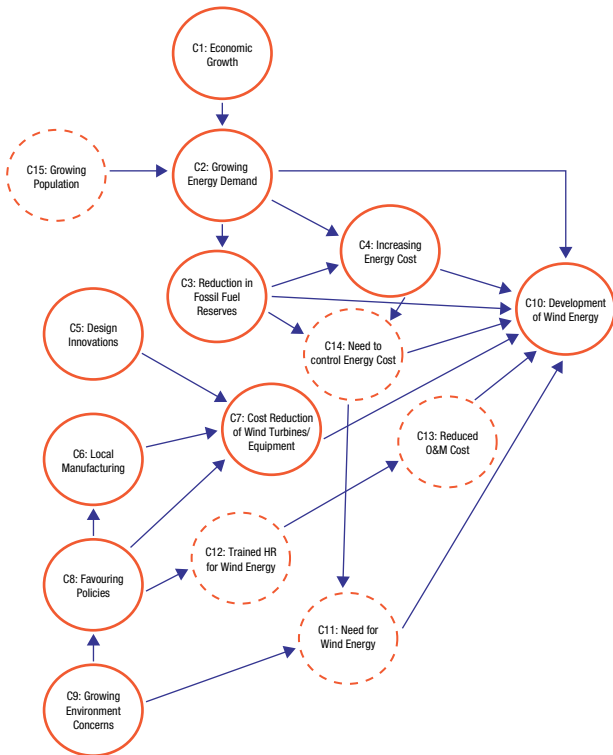

Another recent investigation was conducted by Jetter and Schweinfort (2011) concerning the use of solar photovoltaic panels for residential customers. There are many critical benefits of using photovoltaic panels for sustainable development, especially in developing countries. Already, some developing countries in Africa, as well as India, Pakistan and Indonesia have adopted the use of photovoltaic panels to generate solar power for pumping water. In South Africa, several schools use solar energy generated from photovoltaic panels while other countries, such as the Republic of Congo, have been using photovoltaic panels to run health centres. Additionally, photovoltaic panels have been successfully deployed for charging batteries. The aim of the investigation was to create scenarios with fuzzy cognitive maps to assess the attractiveness of photovoltaic systems using expert knowledge of industry manufacturers, as well as users. Specifically, two studies were carried out: The first involved the opinions of two groups of stakeholders (technologists and customers), whereas the second included six groups of stakeholders (grid experts, market specialists, forecasters, customers, photovoltaic panel users and energy consultants). Figure 6 presents the resulting map after combining the opinions of the two stakeholders involved in the first study.

In the second study, simulations were conducted to assess how the profitability and attractiveness of photovoltaic technologies is influenced by different stages of economic growth and levels of government incentives. Specifically, the current stage of economic growth was changed, first, to continual and, second, to stagnant. This approach using fuzzy cognitive maps can be helpful for local authorities of developing

Figure 6. Integrated Causal Map/Fuzzy Cognitive Map (Jetter and Schweinfort, 2011).

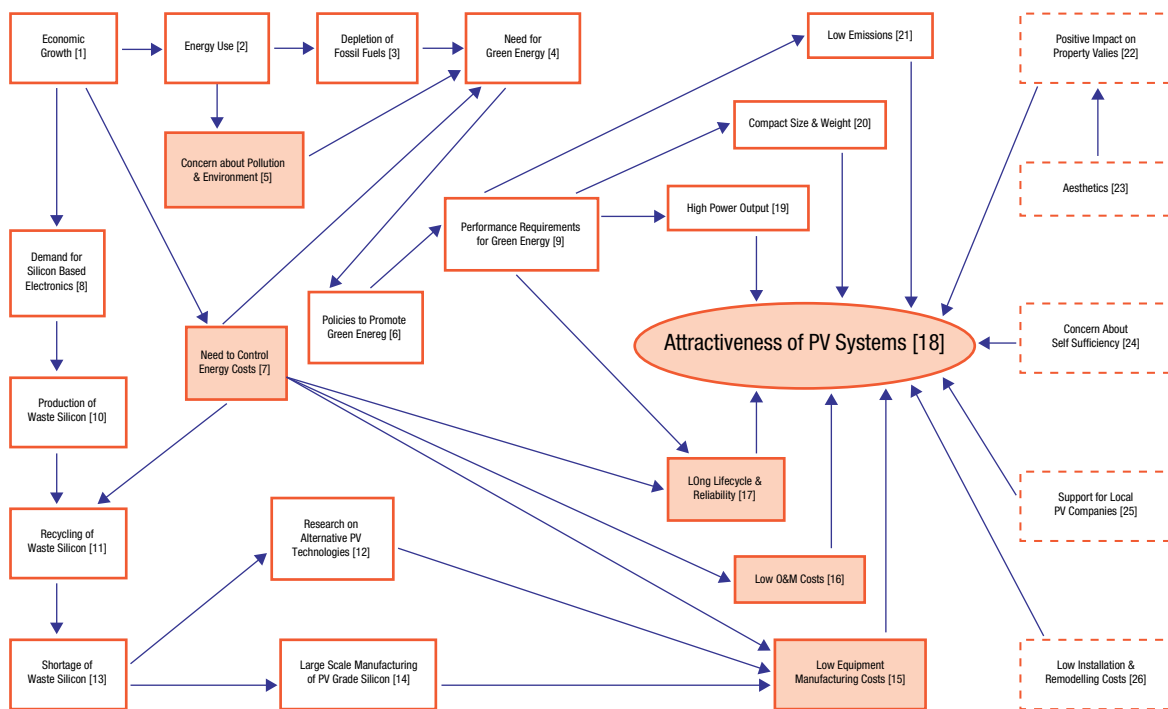

countries to assess the impact that changes to economic growth will have on the levels of residents' attractiveness of photovoltaic panels. In addition, with the necessary modifications, the maps can be used to evaluate the success of the deployment of photovoltaic panels or employed to formulate policies to make the technology more available, affordable and accessible to financially poor areas.

## Challenges

There are several challenges that need to be overcome regarding the application of fuzzy cognitive maps by developing countries. First, it is important to consider whether or not expert knowledge is readily available for governments and local authorities to take advantage of in developing countries. There may be certain domains where policy decision makers may find it difficult to locate and consult a sufficient number of domain experts to help in the construction of such a fuzzy cognitive map. One way to deal with this is to transfer expertise from other government or local authorities that share similar characteristics and need to deal with the same problems. Alternatively, they can refer to governments that have already adopted these maps as a decision-support tool in similar circumstances and make necessary modifications to the map models. However, this may prove too costly for many developing countries if other governments are unwilling to pass on knowledge and provide expertise freely. Available scientific literature can help mitigate these costs. Another challenge involves the participation of stakeholders. Although fuzzy cognitive maps are easy to understand and use, there is still some training and guidance required, particularly when using them to obtain public opinion. Therefore, it is important to provide participating stakeholders, with information, in plain language, on the exact purpose of the fuzzy cognitive maps, and what stakeholders are required to provide. In addition, policy decision makers will require training and material regarding modelling of these maps, as well as how to perform "what-if" scenario analyses in the form of fuzzy cognitive map simulation and interpretation or

defuzzification of results (that is to say, transforming the numerical values of the activation levels back into the qualitative terms defined in the fuzzification). The overall challenge, however, is the ability to find a viable and user-friendly solution that developing cities are able to afford, taking into account the cost of experts, training users, and modelling, as well as simulation software. The cost of experts can be reduced, for example, by having two or more developing cities that require the same fuzzy cognitive map solution to participate in shared consultations. Training costs can be reduced by implementing a "train the trainer" strategy, which leads to having multiple instructors training map users at the same time, thus lowering costs. Finally, software costs can be minimized by using a product that supports fuzzy cognitive map modelling and simulation within a policy decision-making support tool. One such product is the FUPOL (future policy modelling) platform, which is a powerful tool that encompasses the whole policymaking life cycle and allows cities to identify, analyse, implement and monitor policies driven by public demand. This platform also supports policy modelling and simulation with fuzzy cognitive maps and, therefore, developing cities will have the joint benefit of managing policy decisions and assessing the impact of policies in a unified environment.

## Conclusions

This paper discussed the potential of fuzzy cognitive maps as a means of helping decision makers in developing countries tackle policy issues regarding different domains. Specifically, the use of these maps for dealing with water and sanitation matters, as well as energy issues was explored. There are many problems in other policy domains, such as transport, environment, tourism and welfare that can also be overcome using these maps. The benefits of their use lie, primarily, in their simplicity to understand and use for assessing the acceptability and effectiveness of policies. Furthermore, their ability to allow for citizen and stakeholder participation in the actual construction of the maps makes them highly attractive tools for decision makers.



## References

- Amer, M., Jetter, A., & Daim, T. (2011). Development of fuzzy cognitive map (FCM)-based scenarios for wind energy. *International Journal of Energy Sector Management*, 5(4), 564-584.
- Andreou, A. S., Mateou, N. H., & Zombanakis, G.A. (2005). Soft computing for crisis management and political decision-making: the use of genetically evolved fuzzy cognitive maps. *Soft Computing*, 9(3), 194-210.
- Axelrod, R. (1976). *Structure of Decision: the cognitive map of political elites*. Princeton, NJ: Princeton University Press.
- Carvalho J. P., & Tomé, J. A. B. (2004). Qualitative modelling of an economic system using rule-based fuzzy cognitive maps. In *Proceedings of the 2004 International Conference of Fuzzy Systems (Vol.2, pp. 659-664)*. Washington, DC: IEEE.
- Giordano, R., Pasarella, G., Uricchio, V. F., & Vurro, M. (2005). Fuzzy cognitive maps for issue identification in a water resource conflict resolution system. *Physics and Chemistry of the Earth*, 30, 463-469.
- Giordano, R., & Vurro, M. (2010). Fuzzy cognitive map to support conflict analysis in drought management. In M. Glykas (Ed.), *Studies in Fuzziness and Soft Computing: Vol. 247. Fuzzy Cognitive Maps* (pp. 403-425). Berlin: Springer.
- Jetter, A., & Schweinfort, W. (2011). Building scenarios with fuzzy cognitive maps: an exploratory study of solar energy. *Futures*, 43(1), 25-66.
- Kafetzis, A., McRoberts, N., & Mouratiadou, I. (2010). Using fuzzy cognitive maps to support the analysis of stakeholders' views of water resource use and water quality policy. In M. Glykas (Ed.), *Studies in Fuzziness and Soft Computing: Vol. 247. Fuzzy Cognitive Maps* (pp. 383-402). Berlin: Springer.
- Kosko, B. (1986). Fuzzy cognitive maps. *International Journal of Man-Machine Studies*, 24(1), 65-75.
- Mateou, N. H., Andreou, A. S., & Stylianou, C. (2006). Evolutionary multilayered fuzzy cognitive maps: a hybrid system design to handle large-scale, complex, real-world problems. In *Proceedings of the 2006 International Conference on Information and Communication Technologies: From Theory to Applications* (pp. 1663-1668). Washington, DC: IEEE.
- Maruyama, M. (1963). The second cybernetics: deviation-amplifying mutual causal processes. *American Scientist*, 51(2), 164-179.
- McCulloch, W., & Pitts, W. (1943). A logical calculus of ideas immanent in nervous activity. *Bulletin of Mathematical Biophysics*, 5(4), 115-133.
- Mkrtychyan, L., & Ruan, D. (2012). Using belief degree distributed fuzzy cognitive maps for energy policy evaluation. In J. Lu, L. C. Jain & G. Zhang (Eds.), *Handbook on Decision-making: Vol. 2. Risk Management in Decision-making* (pp. 39-67). Berlin: Springer.
- Mouratiadou, M., & Moran, D. (2007). Mapping public participation in the Water Framework Directive: a case study of the Pinios River Basin, Greece. *Ecological Economics*, 52, 66-76.
- Tsadiras A. K., & Margaritis K. G. (1997). Cognitive mapping and certainty neuron fuzzy cognitive maps. *Information Sciences*, 101(1-2), 109-130.
- UNESCO/WWAP (2012). *The United Nations world water development report 4, Volume 1: Managing Water under uncertainty and risk*. Paris, France: World Water Assessment Programme.
- Zadeh, L. A. (1965). Fuzzy sets. *Information and Control*, 8(3), 338-353.



# Geofencing as a Tool for Participatory Processes

○ Dr Anthony Ijeh

Assistant Professor, University of Buraimi, Sultanate of Oman

## Abstract ○

This chapter puts forward a conceptual framework to improve citizen engagement and participation in public consultation processes through the application of location-based services (geofencing). The conceptual framework aims to strengthen the capacity of developing countries in applying technologies that can capture, store, process, communicate and display opinions from citizen engagement during public consultation. The purpose of this chapter is to present the conceptual framework that offers a perspective of geofencing in public consultation that improves access to information

as well as promotes participation in policymaking for the empowerment of the individual citizen and for the benefit of society as a whole. The chapter will, therefore, consider existing technologies and models used in the design and development of electronic governance. In addition, the chapter will consider and define the issues with the use of existing technologies and models for electronic participation. This chapter recommends a framework that mitigates existing barriers to effective citizen engagement and which cause low electronic participation during public consultation.

### Keyword:

Geofencing, E-Participation, E-governance, Public Consultation, Enumeration

## Introduction

Among the collective outcomes of Millennium Development Goals set for attainment in 2015 is global sustainable development with collaborative governance as the basis for public consultation. In order to actualize the common objective the United Nations Human Settlements Programme (UN-Habitat) and Future Policy Modelling (FUPOL) advocates citizen engagement and participation in public policymaking to enable people contribute to issues which affect their daily lives; like proper housing and growth of slums, inadequate and outdated infrastructure such as roads, public transport, water, sanitation, or electricity. Other issues include escalating poverty and unemployment, safety and crime, pollution and health issues, as well as poorly managed natural or man-made disasters and other catastrophes due to the effects of climate change. By contributing to policy and decision-making through electronic participation, citizens can govern themselves using suitable technologies to decide which public services are provided and how.

This chapter offers a perspective of geofencing in public consultation on processes that define the delivery of data and information services where the content is tailored to the location and context of a mobile device. The geofencing tool allows users to engage and participate in electronic governance of their urban area in a unique and innovative way. Using geofencing as a tool for participatory processes provides an alternative to the current models of electronic participation and governance as well as an alternative method of dealing with the barriers faced by citizens of urban areas who want to engage through electronic participation the governance of their public services. Geofencing constituents are made up of geographical information systems, spatial databases, the Internet, the World Wide Web and all information communication technologies.



ELECTRONIC PARTICIPATION (E-PARTICIPATION) IS THE TERM USED WHEN PEOPLE ENGAGE IN POLICYMAKING USING INFORMATION COMMUNICATION TECHNOLOGIES (ICT) THAT MAKE PARTICIPATION IN AND UNDERSTANDING OF THE DECISION-MAKING PROCESSES EASIER.



Electronic participation (e-participation) is the term used when people engage in policymaking using information communication technologies (ICT) that make participation in and understanding of the decision-making processes easier. E-participation has grown out of the resolve by United Nations Member States to work collectively for more inclusive political processes that allow authentic participation by all citizens and the belief in the right of the public to have access to information through participation. The resolve enables this chapter to define e-participation in the context of public consultation as the use of ICT to expand and deepen political involvement by empowering citizens to contribute to decision-making processes. By participating in decision-making processes for public consultation, citizens are empowered to influence decisions of their concern. The benefits to citizens and government alike are a transparent and open government, and a decision-making process that takes the view of all into account. These benefits are in the context of the Millennium Development Goals being pursued and more recently the Post-2015 citizen's initiative.

This chapter will explore if it is possible to use geofencing to overcome the barriers to electronic participation of citizens in decision-making. This chapter asserts that geofencing can enhance participation in electronic governance, in that citizens can participate in a decision-making process for public consultation by virtue of their location. The proposed framework is not a final solution to removing the barriers which cause low electronic participation of citizens, but it supports the debate on how best to increase the use and capacity of electronic governance. It offers an innovative approach to electronic participation, is realistic and focused on its aim, and provides mitigation to a real world problem.

Having used literary enumeration to establish and develop the innovative framework, the outcome demonstrates an improvement of electronic participation where citizens have engaged in public consultation processes using geofencing which meets best practice requirements of the International Standards Organization. The configured geofencing tool adopts human behaviour in real world scenarios and takes into consideration the instability of the surrounding environment and latency that need continual improvement in an enumeration context. The justification for developing the framework is that it is linked to three Millennium Development Goals: urban poverty reduction, environmental sustainability and global partnerships for development.



**Diverse Business People Learning About Social Media.**

© Shutterstock/Rawpixel

In summary the chapter presents geofencing as a tool for participatory processes using a practical framework to demonstrate how citizen participation can develop through the application of location-based services (geofencing). The goal of the framework is to improve access to information and public services as well as promote electronic participation in urban area policymaking for the empowerment of the individual citizen and for the benefit of society. In order to do so, existing technologies and models used in electronic governance participation are discussed. The framework's contribution to public consultation is that it provides much-needed additional capacity by removing existing barriers to the public's engagement with policymakers and participation in the decision-making process.

The objectives of this chapter are to:

- discuss the causes of low citizen e-participation in the context of public consultation
- present an adaptive framework to mitigate the causes of low citizen e-participation
- discuss the expected performance levels of the framework
- discuss the benefits of the framework to citizens and local governments
- suggest future areas for research caused by the framework's development

There have been other research studies on enhancing the participation of citizens in governance. Those presented in this chapter are just a contribution to the research portfolio that focuses on the design and development of instruments for e-participation.

## Background

The seriousness of empowering citizens to participate in policymaking relies on allowing people's voices to be part of key decision-making processes, especially on decisions that can have a direct impact on their lives. The challenge becomes how best to deploy innovative frameworks through technologies like mobile phones that empower citizens to participate meaningfully and effectively in governance, policy, service development and delivery processes.

## Glossary of Key Terms Used in This Chapter

**Electronic participation:** The engagement of citizens by participation regarding electronic governance. It expands a government's instruments for reaching out to and engaging with its people but cannot replace traditional forms of public participation such as face-to-face meetings, paper-based communications, telephone calls and physical bulletin boards (UNPAN, 2014).

**Electronic governance:** A public sector's use of information communication technology with the aim of improving information and service delivery, encouraging citizen participation in the decision-making process and making government more accountable, transparent and effective (UNESCO, 2014).

**Public consultation:** Is a regulatory process by which the public's input on matters affecting them is sought (UK GOV, 2014).

**Future policy modelling:** An integrated approach to policy modelling in which new governance models are used to engage all stakeholders in the whole policy design life cycle starting from the early automatic detection of citizens' needs (FUPOL, 2014).

**Participatory enumeration:** A data gathering process which is to a significant extent jointly designed and conducted by the people who are being surveyed (GLTN, 2010).

**Geofencing:** The application of location-based services where the site of a mobile device using positioning technology to communicate within an area is known (Ijeh, 2009, 2010 and 2011).

**Geographic Referencing:** Geographical coordinates to help identify locations all over the world. Some of these include georeferenced coordinates, such as latitude/longitude and linear referencing, such as street addresses.

Geofencing is used globally to increase the capacity of citizens to make and transform choices into desired outcomes, for example it allows a citizen to engage and participate in selecting suppliers and purchasing goods within an urban area. The geographic limitation inherent in geofencing has many benefits when harnessed and, in practice, is used in a variety of ways including public consultation (Szczytowski, 2014) and (Cirillo et al, 2014). In their study, Brimicombe and Li, (2006) described how harnessing the geographic limitation inherent in geofencing enabled the delivery of information and services tailored to the current or some projected location and context of the user. Figure 1 shows the logical components of a location-based service (LBS) system, **which** can be used to improve electronic governance in public consultation because the systems are centred on the geographical location of a user (Ijeh, 2011).

By using the location of a user as an essential process for providing services, citizens become more aware and dependent on their surroundings, and are able to contribute effectively to debates on policymaking which are dependent on their location (Brimicombe and Li, 2009). Location-based services use global positioning systems, amongst others, to track and locate devices in order to determine the position of the user as shown in figure 2.

Stoiciu (2013) maintains that the development of new technology tools is directly linked to active public and private sector involvement in the delivery of public services, and that all e-governance instruments are directly influenced by transparency, barriers, legal framework, citizenship involvement, education, evaluation tools, infrastructure and investment in technology. Geofencing as a tool for participatory processes is being proposed because it matches the needs of urban residents who wish to engage in policymaking and increases accountability and transparency. However, there are other tools that foster data gathering and communication within urban areas.

Figure 1. Logical Components of LBS Which Can Improve Electronic Governance in Cities (Ijeh, 2011)

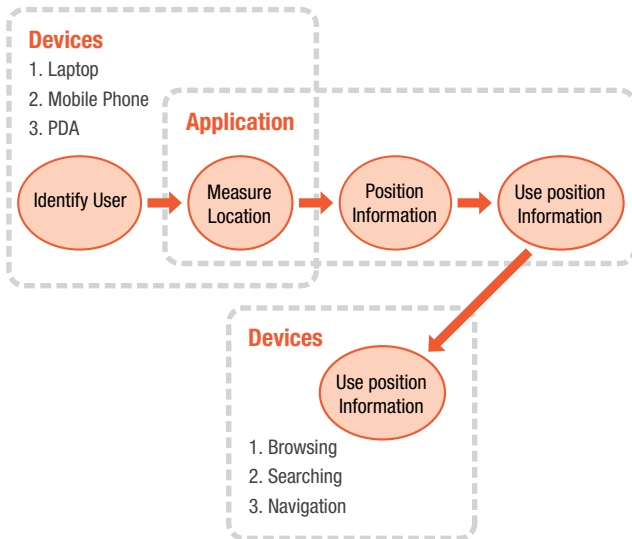
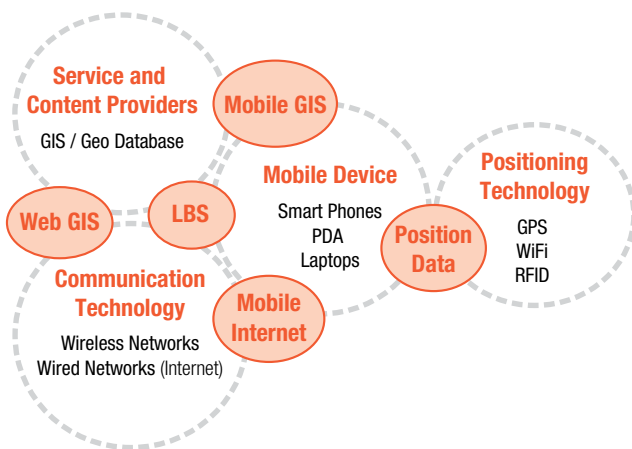

Figure 2. The Intersection of the Technological Hybrid of Geofencing Engineering (Ijeh, 2011)



## Current Technologies Used for Citizen Engagement in Urban Areas:

**Crowdsourcing:** The process of obtaining needed services, ideas, or content (e.g. data) by soliciting contributions from a large group of people, and especially from an online community, rather than from traditional employees or suppliers (IFRC and RCS, 2013)

**Big data or big data analytics:** A range of tools and methodologies that use advanced computing techniques to leverage largely passively generated data, for example those resulting from the use of mobile phones or social networks, and the active collection of observed data by satellites, such as to gain insights for decision-making purposes (IFRC and RCS, 2013)

**Crisis mapping:** Leveraging mobile web-based applications, participatory maps and crowdsourced event data, aerial satellite imagery, geospatial platforms, advanced visualization, live simulation, computational and statistical models to power effective early warning for rapid response to humanitarian emergencies (IFRC and RCS, 2013)

**Digital data collection:** The process of replacing traditional assessments conducted with pens and papers by data collection by humanitarian actors and, where possible, affected populations, supported by widely available and usable digital devices such as smartphones. This results in substantial gains in terms of speed and quality of the data (IFRC and RCS, 2013)

## Causes of Low Citizen Engagement in Public Consultation:

With all the technology and effort being placed on increasing the capacity of citizen engagement with policymakers, why is there low citizen engagement during public consultation? There are various research reports on this which all seem to point to a situation where in spite of the massive investments and advances in e-governance concepts, actual citizen participation through e-consultation and e-forums is almost non-existent. Suh (2007) reported on four causes of low e-participation. The first cause according to the report stated that if opinions proposed by citizens through government instruments were not properly reflected, citizens could feel isolated and lose interest in the effectiveness of the policy in question. This would result in the affected persons having no further role in e-participation in future. Such people, after sharing their experiences, could even cause others to become disaffected. The second cause was that the challenges facing e-governance were not solely technological. Rather, factors such as culture, citizen awareness and traditional practices caused the uptake of e-participation to remain low due to human factors. The third cause of low participation was that the digital divide prevented e-participation and that such inequalities became challenges in an information society using e-government. The fourth cause was the lack of a promotion of citizen participation using different information routes. By failing to do so, the citizenry was unaware of the service. All of the challenges reported were defined as passive participation where no consensus on specific issues were collected or used to make policy. In contrast, active participation is the formation of a consensus such as monitoring administrative activities as shown in figure 3.



GEOFENCING IS USED GLOBALLY TO INCREASE THE CAPACITY OF CITIZENS TO MAKE AND TRANSFORM CHOICES INTO DESIRED OUTCOMES, FOR EXAMPLE IT ALLOWS A CITIZEN TO ENGAGE AND PARTICIPATE IN SELECTING SUPPLIERS AND PURCHASING GOODS WITHIN AN URBAN AREA.



A study by Haratu and Radu (2010) found a different cause of low participation. They reported that even when e-governance took into account the opinions of citizens, participation was lower at the local government level than it was at the regional. The study found the decision-making process included opinions of citizens at local and regional levels, which contrasts the findings of Suh (2007). Kitsing (2010) found that valid identity could also cause low participation because the cost of an identity card reader could hinder the participation of a citizen, but this was more prevalent in the 2000's.

Figure 3. Citizen Participation Activity (Suh, 2007)

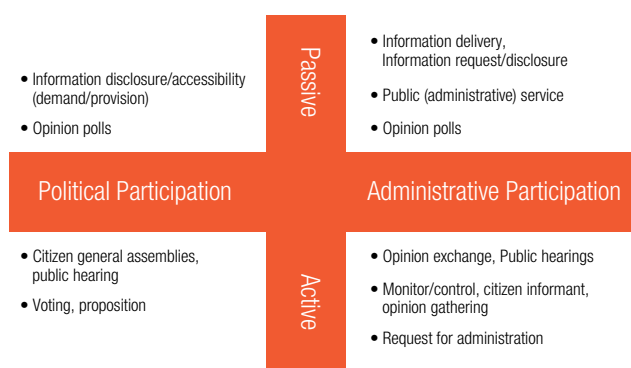

Macintosh (2004) in her study held that stakeholders were required to have certain abilities, such as communication skills, to interpret the typical legalistic terminology of documents in policy discussion and creation before commenting appropriately. In figure 3 social, political, technological, human, and emotional barriers are all identified as the root cause of low participation. These four barriers that prevent the strengthening of e-participation are shown in figure 4. This diagram will enable this chapter demonstrate that where the four barriers identified for causing low participation are mitigated using geofencing as a tool for participatory processes, the capacity for citizen engagement in public consultation is improved.

### Conceptual Framework for Improving Citizen Engagement in Public Consultation:

To design the conceptual framework, each barrier that affects electronic participation is looked at and used to map requirements that mitigate the challenge caused by the barrier. Mapping is executed based on the Organisation for Economic Co-operation and Development (OECD, 2001) framework on electronic participation and consists of classifications for "information", "consultation" and "active participation". Each classification represents how governments engage the public and the flow of information between them. Information is a one-way relationship in which government produces and delivers material for the public. Consultation is a two-way relationship in which individuals provide feedback to government. It is based on the prior definition of information. Governments define the issues for consultation, set the questions and manage the process, while the public is invited to contribute views and opinions. Active participation is a relationship based

Figure 4. There were four types of barriers identified in strengthening e-participation (Stoiciu, 2013)

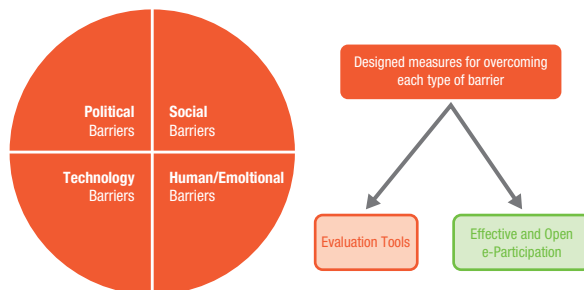

on partnership with government in which citizens actively engage in defining the process and content of policymaking. It acknowledges equal standing for citizens in setting the agenda, although the responsibility for the final decision rests with government. Other studies (Macintosh, 2004) show that there is a need to allow citizens to influence and participate in policy formulation as shown in figure 5.

The proposed geofencing tools framework is reviewed for appropriateness in contributing to policies for public consultation and adopts five high-level stages of the policy life cycle as shown in figure 6.

Geofencing, as a tool for participatory processes, allows policymakers to interact directly and in the early stages of policymaking with the electorate or service users and with those from whom input is being sought on policy. This process supports the view that people have a greater impact on policy content when they are consulted early on in the policymaking process rather than at the end (Macintosh, 2004). People, however, have a number of tasks to perform during electronic participation in order for e-governance to work.

Figure 5. Levels of Participation (Macintosh, 2004)

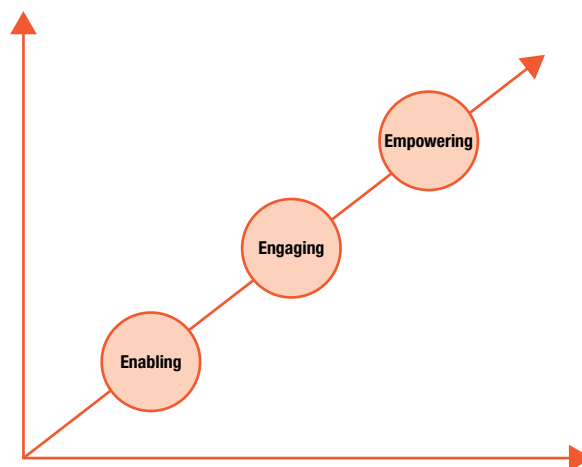
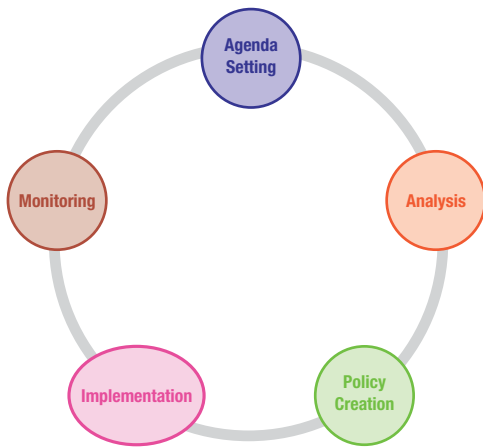



Figure 6. Policymaking Life Cycle (Macintosh, 2004)



These tasks include the following:

- Develop precise participation e-content
- Manage and control the participation process
- Provide and agree background information and or material
- Help to promote the initiative
- Analyse and evaluate the results
- Incorporate results into policy
- Disseminate results

**Main focus of the chapter**

Many relatively large and permanent slums are home to a large proportion of urban dwellers, and they are growing as fast as cities. The figures from the United Nations are stark with one in three people living in a city slum (UN-Habitat, 2008). To combat the trend, some countries have adopted strategic spatial planning, to integrate public-sector functions and include a territorial dimension and new forms of master planning that allow citizens to participate in order to enable social justice (UN-Habitat, 2009).

In practice, much more conventional forms of master planning are still used in many developing countries and fail to accommodate the way the majority of inhabitants live in rapidly growing, poor and informal cities. They have often directly contributed to further social and spatial insignificance (GLTN, 2010). As many United Nations Member States have enhanced participation amongst all their citizens, the most widely used electronic participation model is based on that of the Organisation for Economic Co-operation and Development (OECD, 2001). For the purposes of this study three existing models developed by different institutions, namely: OECD, Inform Consult Empower and the International Association for Public Participation as shown in table 1 were compared.

The key factor that determines the design, deployment and use of particular public engagement technologies for citizens’ benefit is the availability of adequate capacities on the side of governments and the

citizenry (METEP, 2013). The United Nations Department for Economic and Social Affairs Working Group on electronic participation lists three specific areas of concern in developing capacity for electronic participation, as shown in table 2, as:

- open government/data and transparency
- social media
- mobile technologies/devises/platforms

**Table 1** Comparison of E-Participation Models (METEP, 2013)

STAGE	OECD	ICE	IAPP	METHOD OF ENGAGEMENT
1	e-Information	e-Enabling	Information	ICT Channels
2	e-Consultation	e-Engaging	Consultation	Public Consultations (Website)
3	e-Decision Making	e-Empowering	Involving	e-Voting (Via Secure Portal)
4	-	-	Collaboration	Participatory decision making
5	-	-	Empowerment	Delegated Decisions

**Table 2** E-Participation Challenges and Opportunities (DESA, 2012)

SPECIFIC AREA	CHALLENGE	OPPORTUNITY
Open Government	Inaccuracy of data, data protection, privacy concerns, differing social attitudes to open data that are linked to a diversity of cultural contexts	Informed decision-making, greater service innovation and enhanced transparency
Social Media	Governments can be sidelined in online citizen-to-citizen dialogues and discussion	Cost-effective ways for governments to engage with citizens, especially since many citizens are already on popular sites. Provides platforms that enable citizens to become content creators for public services that governments can tap, providing a wealth of information. Strategy for utilising citizen generated content for policymaking and service enhancement processes.
Mobility and Wireless Technology	Traditional e-Government frameworks not covering the potential for convergence with existing channels and multi-channels	New emerging trends that provide opportunities for overcoming the digital divide in terms of geography and uneven infrastructure. Targeting and customisation of information for citizens and also potential to garner very specific data from individuals. Encourages mobile and wireless strategies, making sure there are commensurate data and privacy protection in place.

### Barriers to Engagement in Public Consultation:

This section presents a solution to mitigate the barriers that cause low electronic participation in e-governance using geofencing as a tool for participatory processes. The solution development is directly linked to the active involvement of citizens in the delivery of public services (Stoiciu, 2013).

The solution will, therefore, use the existing barriers to citizen engagement in public consultation to develop robust instruments which take into account transparency, legal framework, citizenship involvement, education, evaluation tools, infrastructure and investment in technologies (Ijeh et al, 2014).

The barriers listed as root causes of low electronic participation are social, political, technological, human and emotional variables. All the causes of low electronic participation shown in table 3 and identified by Suh, 2007; Haratu and Radu, 2010; Kitsing, 2010; Stoiciu, 2013; Macintosh, 2004 were not being addressed because the technologies being used for citizen engagement did not cater for the barriers.

**Table 3** Addressing Barriers to E-Participation Using Geofencing

ENGAGEMENT TECHNOLOGY	POLITICAL BARRIER	SOCIAL BARRIER	TECHNICAL BARRIER	HUMAN BARRIER
Geofencing	✓	✓	✓	✓
Social Media	✓			
Website	✓			
Database	✓			
Blogs	✓			

### Addressing Barriers to Citizen Engagement in Public Consultation:

Geofencing as a tool for participatory processes deals with the barriers discussed in the literature and shown in table 3, by enhancing the engagement of citizens in electronic governance through participation in policymaking. Addressed by the solution are the technical, human and emotional and social barriers faced by citizens in the local government areas Haratu and Radu, (2010). Also addressed is the need for valid identity, Kitsing (2010). Geofencing as a tool for participatory processes has addressed the educational barrier as discussed by Macintosh (2004) and the digital divide caused by new technologies like the smart phone as discussed by Stoiciu (2013). In addressing these barriers and the causes of low participation as shown in table 4, geofencing is now part of the new technologies used in electronic governance as shown in figure 7.

One unique feature of geofencing as a tool for participatory processes is its ability to provide a service that suits every citizen regardless of their background. So, for instance, a citizen's level of education or

Figure 7. Role of Digital Technologies for Electronic Participation

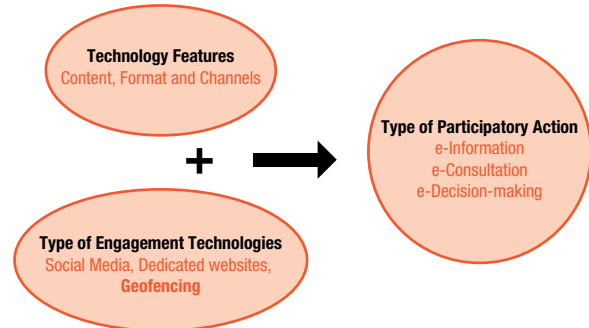

digital literacy cannot be an issue because geofencing as a tool for participatory processes provides a service that enables citizens with both enumerations. This key ability is what replenishes trust and faith in the political process and encourages citizens to participate in the decision-making affecting their communities. The lack of trust usually causes low participation. However, this trend can be changed if the governments are willing to invest in geofencing as a tool for participatory processes so as to enable all their citizens to participate.

Features of Geofencing as a Tool for Participatory Processes Applied to Barriers in Context of Developing Countries

**Component 1:** SMS cell broadcasting – Sends message - Point to Area (Government)

**Features**

- Authorities can broadcast messages to anyone in a given geographical area without needing any pre-registered numbers or infringing on privacy.
- Messages can be tailored to different geographical areas and use dedicated communication channels thus eliminating congestion.
- There is also no way for an outsider to generate a cell broadcast message, so false emergency alerts are considered unlikely.
- While mobile phones have to be switched on to receive the alerts, cell broadcasting allows for repeat messages to be broadcast periodically.
- Simultaneous multilingual broadcasting is also possible.
- The messages flash automatically on the screen of mobile phone sets, instead of going to message boxes. This way, a user does not even need to push a button.

**Component 2:** SMS Software Platform - Allows Two-Way Communication (Government & Citizen)

**Features**

- It allows users to send text messages to groups of people and to receive messages on their mobile phones and computers.
- The software platform does not require an Internet connection. It can work with any plan on all GSM phones, modems and networks. It has been designed to operate from a laptop so that it can be used during power outages or while travelling.

**Table 4** Requirements Mapping for Geofencing as a Tool for Participatory Processes

BARRIER	CHALLENGES CAUSED BY BARRIER	GEOFENCING SOLUTION TO BARRIER
<b>Political</b>	Legislation	
	Transparency	✓
	Active Citizenship	✓
	Top down engagement of Citizens	✓
	Measuring and Evaluating Participation	✓
	Local, National and International Cooperation	
<b>Social</b>	Poverty	
	Bottom up engagement of citizens	✓
	Public responsiveness	✓
	Receiving Information	✓
	Local, National and International Cooperation	
	Digital divide and inclusiveness	✓
<b>Technical</b>	Infrastructure	✓
	Implementation of engagement technologies	✓
	Open Government Data	✓
	Affordable ITC tools and technical assistance	✓
	Access to quality ICT content	✓
<b>Human</b>	Lack of education	✓
	Lack of digital literacy	✓
	Lack of trust in government accountability	✓
	Lack of communication between stakeholders	✓
	Lack of trust caused by past political problems	✓

- The software becomes a communications hub where the numbers of incoming or outgoing SMS messages are saved.
- It is scalable and can be used to reach large groups.
- It can be used worldwide by switching the SIM card.
- It can be used for human rights monitoring, emergency alerts, field data collection, healthcare information requests, and public surveys, among many others.
- In short, the software can be used for almost anything that requires two-way communication between two parties, or between a central party and a crowd.

**Component 3:** Location-based Services – Pinpoint targeting of devices in an area (Government)

**Features**

- A simple service that restricts correspondence via short message service (SMS) to devices in a selected area determined by a ubiquitous interface for telecommunication.
- It meets the requirement that the service should be accessible to all without handset modifications, as SMS is available on all wireless handsets and requires no user provisioning.

- Location information would be provided in the form of a simple text message, returned to the user in response to a request, also generated by SMS. This eliminates the need to display maps to pinpoint the location of targets, and does not require the use of Global Positioning Service (GPS) as a means of providing location information.
- Functionality of geofencing as a tool for participatory processes in developing countries:
  - overcomes the barrier faced by most citizens in developing countries who do not use smart phones by not using GPS
  - overcomes the barrier of complex mapping data in the user interface by sending a text message of the location of the respondent on request
  - overcomes the need for network infrastructure by not using Internet connection
  - overcomes the possibility of false emergency alerts by sending messages from an authoritative source using SMS cell broadcasting
  - overcomes the barrier caused by language, by simultaneously broadcasting in many languages
  - overcomes the power outage problem by not requiring direct current to work
  - overcomes the need to change SIM cards or mobile phones not configured for a particular network by not being designed for any particular network

Geofencing as a tool for participatory processes can be used without modification to mobile phones, so that it is accessible to a large pool of potential users, regardless of the mobile device they are using. Following the requirements, analysis and design of the solution in table 4; the high-level view of the framework is shown in figure 8. The key area of the conceptual framework is the solution development. The logical components form the core components of the security solution. The development is not new technology but rather the application of the logical components in a different way than to what exists. The aim of the solution is to demonstrate that in applying a user’s location as a holistic control mechanism it is possible to enhance citizen engagement in policymaking through electronic participation.

**Figure 8.** High-Level View of the Conceptual Framework

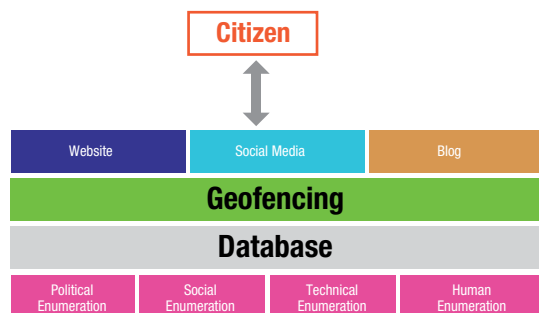

Within the limits of this chapter, the evaluation criteria is based on the ability of the solution to mitigate the identified barriers, successfully, so as to remove the challenges faced by citizens in participating. The

solutions architecture for the framework is made up of the Location-Based Service technology as shown in figure 8. It does, however, adopt pre-set enumerations for consistency. A request for access is sent automatically to the user services and profile server once the citizen's mobile device enters a location. The submitted request is then sent as a signal to the database server to authenticate the user's profile. If the authentication is successful, the positioning technology server is sent a signal, which is passed to the citizen's mobile device being used to participate so as to monitor the mobile device's current position at set time intervals.

How does geofencing mitigate the barriers? It does so by configuring them as algorithms that are then removed from challenging the citizen.

## Practical Examples of Web Page Geographic Referencing by Direct Participation

The versatility of location-based services is demonstrated by the type of crisis and location where it has and can be used. As shown in table 5, web page geographic referencing has been used for human mobility and crisis monitoring. Archival literature shows that this type of humanitarian technology was first used in 2005 by the British Broadcasting Corporation and can be repurposed for public consultation.

**Table 5** Practical Examples of Web Page Geographic Referencing by Direct Participation

ORGANIZATION	LOCATION	TYPE OF CRISIS	TECHNOLOGY	YEAR
Ushahidi	Kenya	Electoral violence	Web page geographic references	2008
Sinsai.info	Haiti	Earthquake	Web page geographic references	2010
OCHA	Libya	Logistics	Web page geographic references	2011
QCRI	Philippines	Flooding	Web page geographic references	2012
Red Cross	America	Flooding	Web page geographic references	2013

**Ushahidi:** In response to the needs of civil society during the 2008 post-electoral violence in Kenya, Ushahidi was developed to enable messages from multiple sources - such as SMS, e-mail, Twitter and the web - containing geographic references to be mapped and serve as a source of information.

**Sinsai.info:** This open-source crowdsourcing platform launched four hours after the 2010 Haiti earthquake enabled survivors to send text messages for help, which were in turn translated, organized and mapped by a team of volunteers in Boston, the United States

**STBF:** Created by the United Nations Office for the Coordination of Humanitarian Affairs (OCHA), the Standby Task Force is a live crisis map of Libya sourced from relevant social media content, such as Twitter, Facebook, Flickr and You Tube. It enables OCHA to provide a full list of indicators such as movements of people, health, logistics and security threat.

**QCRI:** Shortly after Typhoon Pablo struck the Philippines, social innovators at the Qatar Computing Research Institute launched MicroMappers, which is a collection of microtasking apps for crisis mapping. This enabled OCHA in the Philippines to achieve an unprecedented 12-hour turnaround in sharing a crisis map entirely made of crowdsourced, user-generated multimedia content treated on a microtasking platform in support of official humanitarian operations that would normally take weeks.

**Red Cross:** In the early 1990s, the American Red Cross started developing web pages for monitoring emergencies. These have since been repurposed for geographic referencing. In the aftermath of Hurricane Sandy in 2012, the American Red Cross used maps to summarize damage assessment survey results from more than 90,000 respondents to help the Red Cross and government services to coordinate and target service delivery.

## Lessons Learned and Benefits of Using Geofencing as a Tool for Participatory Processes

Although many social innovators work on web pages with geographic referencing there are no standards for implementing or adopting them with mobile technologies such as smartphones. This inability is the reason behind the colossal volume of data produced by affected communities. For this reason, in order to encourage citizen participation in public consultation, appropriate legislation that supports all its processes including the mobile technologies and devices used for participating in public consultation need to be in place. For trust and transparency, workshops explaining how the public consultation processes work, including how electronic participation tools (hardware and software), will enable each citizen to participate in a reliable and transparent public consultation process that decides the future of the community based on consensus. Geofencing as a tool for participatory processes enables the profiling of citizens during public consultation. It does this by restricting the participation of citizens to areas relevant to the public consultation.

Using the Future Policy Modelling (FUPOL, Anon) life cycle as a guide has linkable benefits to citizens, politicians, civil servants, enterprises and local governments, which include outcomes that support governments in:

- gaining a better understanding of the citizen's needs and businesses activities
- getting direct feedback from all political stakeholders through multichannel social network analysis based on the communication between politicians and citizens
- predicting the impacts of policy measures leading to a more efficient implementation of government policies
- taking better decisions based on forecasts regarding the potential impact of political decisions
- achieving a high-level engagement of citizens and a wider use of new information and communications technology tools, resulting in a higher innovation potential related to the interaction of citizens with their respective governments

Some of the benefits of the conceptual framework to citizens and

local governments include the removal of barriers that cause low e-participation. It does so by engaging its citizens: governments can explain legislation using geofencing as a tool for participatory processes, which enables citizens to listen in different languages the legislation being enacted or discussed. This promotes transparency and demonstrates government's commitment to involve all citizens, which promotes active citizenship. This is because citizens feel obliged to partake when all the necessary support for them to do so is provided. Geofencing as a tool for participatory processes promotes top-down engagement by allowing government to talk directly to its citizens. This brings all stakeholders closer because no barriers exist to keep them apart. A special feature of the geofencing solution is that it has an analytics function and remits real-time data on surveys and decision to all participants. This allows the government to evaluate its efforts and the impact of the survey or discussion being held. Whilst the geofencing solution allow governments to interact with each other as an interface cooperation between countries, this can only become a reality if governments want to participate in the same discussion. For this reason the enumeration indicator has been left unticked in table 4.

Another benefit of the geofencing solution is that it takes into account the individuality of citizens, which includes providing and given access to different modes of interface such as websites, portals, blogs and forums. This enables citizens to become better informed about the discussion or issues affecting their communities. Whilst the level of poverty cannot be changed by the geofencing solution, it can be used as a resource that enables citizens to provide for themselves. Geofencing also provides a means for allowing bottom-up engagement between citizens and their government representatives so they can engage in the decision-making process. This allows the public to respond to government surveys because they feel they have a voice and can use geofencing to communicate that voice. This also allows the citizen to obtain information from appropriate sources like designated government portals. Announcements can also be made via geofencing as targeted participants are sent information relating to their location. Cooperation between governments using the geofencing solution is dependent on the will of each government to participate. Geofencing as a tool for participatory processes removes the digital divide between citizens because it is designed in a way that the technical features remain behind the interface so that each citizen can use the keypad regardless of their educational background, exposure or language preference.

Geofencing is appropriately designed to be future proof and allows Internet access at a speed, which is internationally acceptable. As an engagement technology, geofencing is produced at minimum cost so that citizens the world over can enjoy the e-participation barrier-breaking technology. Open government data, social media, mobile and wireless communications, including websites and portals are all accessible with geofencing. Service level agreements will be put in place to ensure that citizens are not denied access to quality national information and communications technology content.

## Design of Geofencing as a Tool for Participatory Processes

Public consultation through geofenced electronic participation tools such as SMS texts allow citizens of an area to contribute through consultation in openly transparent processes to their communities. Concerned citizens are activated using situations affecting them directly thereby enabling the consultation to be focused and meaningful. Archival literature reports that citizen activism such as geofenced electronic participation will enable municipalities and governorates in developing countries to communicate their public consultation processes, which will lead to greater participation with their citizens as shown in figure 9.

Figure 9. Applying Geofenced Electronic Participation in Public Consultation

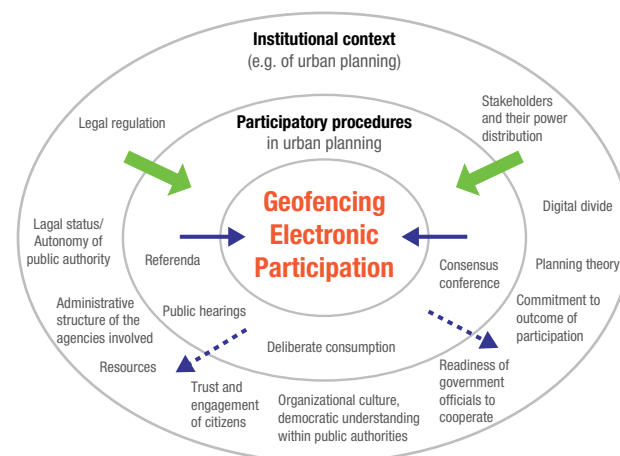

## Future Research or Operational Directions

In the future, universal standards must be put in place so that communication across boundaries is done in a structured and standardized way. In addition, a dedicated radio frequency is to be allocated to geofencing solution so that downtimes can be reduced. Geofencing creates opportunities for e-participation by ensuring that all citizens partake in the decision-making and democratic systems. Funding is being sort to provide proof of concept for the geofencing solution, which enhances the capacity of government and citizens in e-participation and e-governance.

## Conclusion

This chapter has presented a conceptual framework that enables citizen participation to develop through the application of location-based services (geofencing). The chapter's aim of strengthening the capacity of developing countries in applying new information and communications technologies for citizen engagement has been demonstrated. The conceptual framework offered a perspective of geofencing in public consultation that improves access to information and public services as

well promoting e-participation in policymaking for the empowerment of the individual citizen and for the benefit of society. This chapter considered existing technologies and models used in the design and development of e-governance. The chapter also discussed e-participation and the use of these existing technologies and models in order to present a conceptual framework to mitigate the barriers in using existing technologies and models, which cause low e-participation.

## References

- Ali, M. (2005). Advanced Location Based Service. IEEE/IEE Applied Electronics 2005 International. Conference., The Department of Applied Electronics and Telecommunications, University of West Bohemia, Pilsen, Czech Republic, 7 - 8 Sept., 2005, pp.13-16
- Brimicombe, A.J. and Li, Y. (2006). Mobile Space-Time Envelopes for Location-Based Services; Transactions in GIS, 10: (1), pp5–23.
- Brimicombe, A.J., and Li, C. (2009). Location-based services and Geo-Information Engineering. Chichester, UK: Wiley-Blackwell, pp1-392.
- Cirillo, F., Jacobs, T., Martin, M., Szczytowski, P. (2014) Large Scale Indexing of Geofences. In: The Fifth International Conference on Computing for Geospatial Research and Application, pp 1- 12. Retrieved 30 July 2014. Available from <http://semanticcommunity.info/@api/deki/files/30392/4321a001.pdf> ISBN: 978-1-4799-4321-0/14
- FUPOL (Anon) An Integrated Approach to E-Governance, E-Participation and Policy Modelling. Available from [http://www.fupol.eu/pdf/public\\_deliverables/fupol\\_brochure\\_modules.pdf](http://www.fupol.eu/pdf/public_deliverables/fupol_brochure_modules.pdf)
- GLTN (2010). Global Land Tool Network Brief 1: Tackling tenure security in slums through participatory Enumerations, pp1-2. Retrieved 3 May 2014. Available from [http://www.glt.net/downloads/GLTN%20Documents/2992\\_alt.pdf](http://www.glt.net/downloads/GLTN%20Documents/2992_alt.pdf)
- GLTN (2010). Global Land Tool Network Brief 2: Improving data collection for urban planning through participatory Enumerations, pp1-2. Retrieved 3 May 2014. Available from [http://www.glt.net/downloads/GLTN%20Documents/2993\\_alt.pdf](http://www.glt.net/downloads/GLTN%20Documents/2993_alt.pdf)
- GOV.UK (2014). Publications on all consultations, In the Government Digital Service (GDS) is leading the digital transformation of government. Available from [https://www.gov.uk/government/publications?publication\\_type=consultations](https://www.gov.uk/government/publications?publication_type=consultations)
- Haruta, C., and Radu, B. (2010). Citizen Participation in the Decision-making Process at Local and County Levels in the Romanian Public Institutions. Transylvanian Review of Administrative Sciences 31: pp76-92.
- IFRC and RCS (2013). World Disaster Report: Focus on technology and the future of humanitarian action. Retrieved 6 June 2014. Available from <http://www.ifrc.org/PageFiles/134658/WDR%202013%20complete.pdf>
- IFRC and RCS (2013). World Disaster Report: Focus on technology and the future of humanitarian action. Retrieved 6 June 2014. Available from <http://www.ifrc.org/PageFiles/134658/WDR%202013%20complete.pdf>
- Ijeh A.C., Brimicombe A.J., Preston D.S., Imafidon C.O. (2009a). Geofencing in a security strategy model. In: Jahankhani H, Hassami A, Hsu F (eds) Global security, safety and sustainability, vol 45, 1. Springer, New York, pp 104–111
- Ijeh A.C. (2010). Wireless Security Model. Lodged with the Intellectual Property Office UK: Date Lodged: 27 Oct 2010. Applicant: Ijeh AC (Journal 6342) Patent GB1018091.7, Journal No. 6342, 1–13
- Ijeh A.C. (2011). Geofencing as a Security Strategy Model. Professional Doctorate Thesis, University of East London.
- Ijeh, A.C., Brown, J., Haleeb, A.L., (2014). Education and Sustainable Development in Oman: The Contribution from Higher Education IN W. Leal Filho (ed.), Transformative Approaches to Sustainable Development at Universities, World Sustainability Series, Springer International Publishing Switzerland, pp1-18.
- Kitsing, M. (2010). An Evaluation of E-Government in Estonia. Paper presented at the conference "Internet, Politics and Policy 2010: An Impact Assessment conference", Oxford University.
- Macintosh, (2004). Characterizing E-Participation in Policymaking. In Proceedings of the 37th Hawaii International Conference on System Sciences, pp1-10. IEEE Press
- METEP (2013). Measuring and Evaluating E-Participation: Assessment of Readiness at the Country Level, pp1-24.
- OECD, (2001). Citizens as Partners: Information, Consultation and Public Participation in Policymaking: OECD.
- Szczytowski, P. (2014). Geofencing-based Disaster Management Service. In: The 2014 ASE BIGDATA/SOCIALCOM/CYBERSECURITY Conference, pp 1 – 12. Retrieved 30 July 2014. Available from [http://www.ase360.org/bitstream/handle/123456789/144/smartlife2014\\_submission\\_1.pdf?sequence=1&isAllowed=y](http://www.ase360.org/bitstream/handle/123456789/144/smartlife2014_submission_1.pdf?sequence=1&isAllowed=y)
- Stoiciu, A. (2013). Strengthening E-Participation: Overcoming Obstacles for Better Consultation Mechanisms. Case studies, IN E-Participation: Empowering People through ICTs Geneva, Switzerland, pp1-17. Retrieved 3 May 2014. Available from <http://workspace.unpan.org/sites/Internet/Documents/UNPAN90477.pdf>
- Suh, S.Y. (2007). Promoting Citizen Participation e-Government: From the Korean Experience in e-Participation. Retrieved 5 May 2014. Available from <http://unpan1.un.org/intradoc/groups/public/documents/un/unpan020076.pdf>
- UNESCO (2014). E-Governance Capacity-building. Retrieved 13 May 2014. Available from [http://portal.unesco.org/ci/en/ev.php-URL\\_ID=3038&URL\\_DO=DO\\_TOPIC&URL\\_SECTION=201.html](http://portal.unesco.org/ci/en/ev.php-URL_ID=3038&URL_DO=DO_TOPIC&URL_SECTION=201.html)
- United Nations, Department of Economic and Social Affairs, Division for Public Administration and Development Management (2012). United Nations e-Government Survey 2012. E-Government for the People. February 2012. Department of Economic and Social Affairs. New York. Working Paper No. ST/ESA/PAS/SER.E/150
- United Nations, Department of Economic and Social Affairs, Division for Public Administration and Development Management (2014). United Nations e-Government Survey 2014. E-Government for the future we want. May 2014. Department of Economic and Social Affairs. New York. Working Paper No. ST/ESA/PAD/SER.E/188
- UN-Habitat (2008). State of the World's Cities Report 2008/9: Harmonious Cities. London. Retrieved 6 May 2014. Available from <http://tinyurl.com/yhhh68v>
- UN-Habitat (2009). Global Report on Human Settlements 2009: Planning Sustainable Cities: Policy Directions.







# Technology Democratizes Information and Promotes Transparency in Public Management

Our São Paulo Network – Sustainable Cities Programme  
Brazil

## Abstract

The Sustainable Cities Programme is the first initiative in Brazil that submitted an integrated set of tools for discussion and intervention in cities, including diagnosis, planning, monitoring and responsibility by means of guidelines and indicators.

The Programme provides an agenda for the cities' sustainability that handles different areas of public administration, based on 12 thematic foundations, and counts on basic and general indicators. Aiming at building a successful public administration, capable

of improving the quality of life of their residents, cities need to use the platform, which has been developed to hold the indicators and to adopt planning methods such as the Plan of Goals. The indicators allow for follow-up of the evolution of cities and their achievements, in addition to embarking on comparative analyses of them. Currently, there are 273 Brazilian signatory cities making a diagnosis of their needs and undertaking to fulfil the Programme's goals. The final objective is to make the updated and accurate information powerful administration instruments.

### Keyword:

Sustainability, participation, transparency, governance

## Introduction

Increasingly, city officials, must exercise public administration efficiently, transparently and sustainably. As half of humanity lives in cities, this is one among several reasons which, at present, makes their reality more complex. According to United Nations data, 60 per cent of the world's population will be urban in 2030 and 70 per cent in 2050 (UN-Habitat, 2012). Today, Brazil's urban population is at 85 per cent; and to the extent that the cities expand in size and population, the difficulty in maintaining urban space, social and environment balance is also greater.

In the 1990s, Brazil adopted a new format for the public policy administration, which is now part of the new institutional process implemented and backed by the 1988 Federal Constitution. This format established decentralization and participation as the main foundations of a democratic public administration at the federal, state and municipal levels. "However for this administrative format to succeed, civil society, businesses which uphold social and environmental responsibility, as well as universities and community leaders, must be involved in the establishment of ethics in governance. This would give local residents greater say in the running of public affairs at all three governmental levels. The involvement of such groups is particularly applicable where public officials have expressed their desire to adopt innovative and participatory policies in order to achieve the sustainable development of their cities.

Adoption of this administrative model requires the training of the involved actors and development of local instruments and practices

so that the evolution of the quality of life, public policies and budget execution can be evaluated. This task can be achieved by surveying and monitoring indicators that are easily accessible online so that interested citizens can know of local policies, their impacts and results, as well as develop their own evaluation capacity. Thus, building information, monitoring and having a social control network in local civil society becomes very important, in the implementation of public policy.

Within this context, the Sustainable Cities Programme, one of the undertakings of "Our São Paulo Network", provides the necessary tools and suggests an agenda for sustainability where the local governments undertake to survey, organize and provide information on their respective cities. Additionally, based on these organized data, the programme guides administrators in formalizing planning of their activities in a transparent manner so that the public can follow developments made by their municipalities.

The innovative initiative of the Sustainable Cities Programme strengthens when tied to the City of São Paulo Executive Plan, pursuant to Amendment No. 30<sup>1</sup> to the city's organic law sponsored by "Our São Paulo Network". The law obliges the chief administrators of cities to make public, within the first 90 days of office, a "Plan of Goals" for their cities. The plan allows for public administration officials to govern guided by indicators that spell out specific goals; and for the administration to promote issues such as sustainable development, social inclusion, human rights and urban mobility.

Figure 1. The Website São Paulo Citizen Observatory

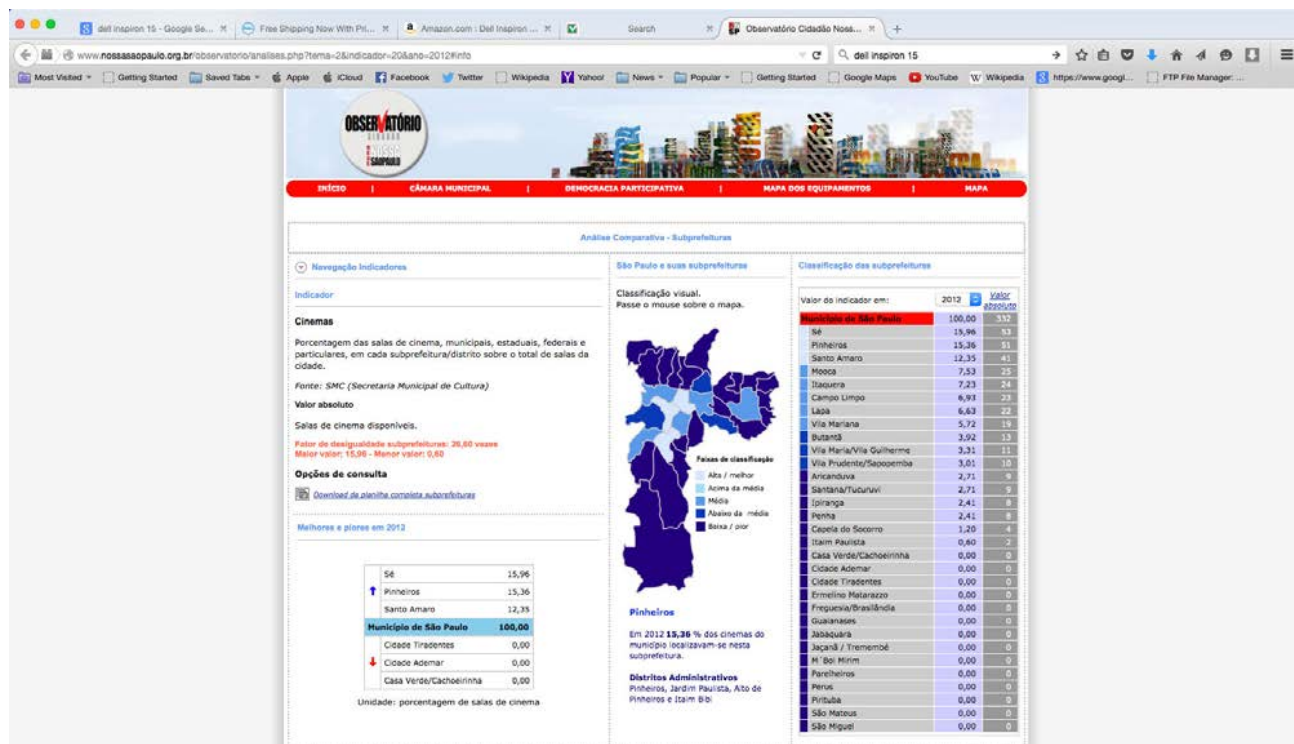



**Training Session of the Sustainable Cities Programme in the city of Rio Branco, Acre**

Following São Paulo's example, other Brazilian cities adopted the legislation and currently do submit the Plan of Goals; the cities of Córdoba and Mendonça in Argentina have followed suit. Some Brazilian cities though, such as Porto Alegre and Recife, do not have the specific legislation but have prepared the Plan of Goals at the initiative of the Sustainable Cities Programme. In this regard, the Bill of Amendment to the Constitution (PEC 52/11), which would oblige all tiers of government to prepare the Plan of Goals, is at its final reading at the National Congress.

Therefore, the purpose of this article is to analyse the urban reality; report and evaluate e-governance mechanisms used for the improvement of city administration as well as for the upgrade in the quality of life of residents. The evaluation is conducted transparently through exchange of information, data access and comparison, as well as progress in the adoption of participative and democratic governance.

## Background

In Brazil, the complexity of its cities is even more contradictory. This is noticeable with the country's rapid urbanization. Most cities have been expanding spatially while there are transition areas and significant rural agricultural expanses where the country's entire natural wealth is preserved.

Thus, we can think about using instruments that can enable public administrations to exercise democratic governance, with a comprehensive view of the future of the city. These instruments such as urban planning, Plan of Goals and evaluation of the indicators can help solve the great challenge of effectuating ample participatory government.

In this regard, the Sustainable Cities Programme recommends greater social and environmental equity where society is involved in the decision-making processes. For success in municipal administration, the Programme suggests the adoption of planning methods which are

liable to provide positive results. The proposal is that the city examines the territory, after which public debates would be held. Then, the results of examination, planning methods and indicators would be circulated and collective interests considered. An efficient examination of the reading and the due circulation of the information are the path for a democratic government and the construction of a fair, democratic and sustainable city.

The Sustainable Cities Programme suggests measures to stimulate participatory governance, planning and greater agility in city administration. One proposal is that signatory cities take an inventory of their social, economic, political, environmental and cultural sphere indicators based on 12 thematic foundations. The purpose of this action is to provide the cities instruments with which to prepare a detailed diagnosis and improve their administrators' knowledge of the activities and realities of their cities. This action is designed to enable administrators identify priorities in activities so that they could draw up their Plans of Goals. The Sustainable Cities Programme provides several national and international examples of participatory governance, planning and flexible administrations that can be replicated.

These examples are available on the website of the Good Practices Programme<sup>2</sup> and are always presented during team training carried out in the cities by the Sustainable Cities Programme.

## E-governance: a path for more sustainable cities

### Focus on the Sustainable Cities Programme

The Sustainable Cities Programme started in 2011, when mayoral candidates and political parties undertook, in a written statement, to implement the Programme if elected. In practice, this meant that municipal governments agreed to implement administration priorities which take into consideration local economic, social, environmental and cultural sustainability needs. Currently, this undertaking continues to be the instrument binding the cities to the Programme, whereby the administrators assume real commitment and the cities ensure these are honoured.

In order to meet such demand in the search for a fairer society, the Programme submits an integrated set of tools for administration and intervention in the city, including diagnosis, planning, monitoring and rendering of accounts by means of guidelines and indicators approaching different areas of public administration, via 12 thematic foundations.

Since the start of the Programme, organized information has proven to be essential to the application of all aspects of governance. In this regard, the Programme considers new management and rights guarantee instruments established by recent laws. The Law on Access to Information No. 12.527/2011, a tool for exercising a transparent administration of national scope, regulates the right to public information, for which there is already provision in the 1988 Federal Constitution.

Anyone should be able to access information of public interest using technology. Thus, the law envisages, among other things, reducing the

Figure 2. Information from a Signatory City

**Indicadores Cidades Sustentáveis**

### Curitiba, PR

**Cidade:** Curitiba  
**Estado:** Paraná  
**País:** Brasil

**População total:** 1.848.946 habitantes (2013)  
**População rural:** 0 habitantes (2010)  
**População urbana:** 1.776.761 habitantes (2012)  
**População mulheres:** 916.792 habitantes (2010)  
**População homens:** 835.115 habitantes (2010)

**Número de pessoas por quilômetro quadrado:** 4.030,00 hab/km<sup>2</sup> (2010)  
**Área total do município em quilômetros quadrados (km<sup>2</sup>):** 43.467,00 km<sup>2</sup> (2012)

Curitiba é uma palavra indígena que significa "muito pinhão", semente da árvore dominante na região. Curitiba é a capital do Estado do Paraná, um dos três estados da Região Sul do Brasil. Foi fundada em 1693 e, de acordo com Último Censo Demográfico do IBGE, apresenta 434,67 km<sup>2</sup> e 1.751.907 habitantes. De norte a sul, seu território possui 35 km e de leste a oeste 20 km. A cidade está a 934 m acima do nível do mar, sendo seu ponto mais elevado ao norte, no bairro Lamenha Pequena, com 1.021 m de altitude. Curitiba, além de sinônimo de planejamento urbano eficiente e de elevados níveis de qualidade de vida, é um dos mais importantes centros de negócios do Brasil, em boa medida devido às primeiras características ou qualidades citadas. O planejamento urbano que resultou numa cidade bem estruturada, com boa mobilidade para as pessoas, pelo transporte público eficiente, as vias estruturais de tráfego, a extensa rede

Indicadores separados por eixos

Indicadores separados por região

Figure 3. Signatory Cities

**Indicadores Cidades Sustentáveis**

Institucional | Notícias | Cidades Participantes | Eixos | Indicadores | Boas Práticas | Biblioteca | Prêmio PCS

Inicio > Cidades Participantes

### Cidades Participantes

O mapa apresenta a lista completa dos prefeitos(as) eleito(as) nas eleições municipais de 2012 e partidos políticos que assinaram a carta-compromisso (de prefeitos e de partidos políticos), do Programa Cidades Sustentáveis.

Pesquise selecionando os pontos do mapa ou utilizando os filtros abaixo, que permitem o acesso aos signatários por estado, cidade e partido político. Os dados estão disponíveis para download em formatos abertos: csv, xls e txt.

Listar Prefeitos  Listar Partidos Políticos

Filtro





 GOVERNANCE	 EDUCATION FOR SUSTAINABILITY AND QUALITY OF LIFE
 COMMON NATURAL RESOURCES	 VIBRANT, CREATIVE AND SUSTAINABLE LOCAL ECONOMY
 EQUITY, SOCIAL JUSTICE AND CULTURE OF PEACE	 RESPONSIBLE CONSUMPTION AND LIFESTYLE OPTIONS
 LOCAL MANAGEMENT FOR SUSTAINABILITY	 BETTER MOBILITY, LESS TRAFFIC
 URBAN PLANNING AND DESIGN	 LOCAL ACTION FOR HEALTH
 CULTURE FOR SUSTAINABILITY	 FROM LOCAL TO GLOBAL

cases of misuse of resources by making available public administration data. Another proper tool for generating information and analysing social needs is the survey and evaluation of indicators. Such instruments help in consolidating a more active and participant society in public administration.

The construction of indicators suggested by the Sustainable Cities Programme allows for classifying the data obtained, evaluating the challenges, and knowing the problems and potential of each place's real conditions. The indicators allow for monitoring the evolution of the cities over time and making comparative analyses between cities and the cities' subdivisions (districts or neighbourhoods). By examining the 12 thematic foundations of the Programme (that submits the proposal to the cities for filling in the data regarding 100 basic indicators and more than 300 general indicators) the administrators are able to provide an overall view of the territory, and thus make easier the drafting of integrated public policies to solve problems. For example, the common natural goods theme, among several indicators, recommends that information is surveyed about public drinking water supply in the urban area, the sewage system and untreated sewerage. Those indicators are linked to that of the theme on local action for health that suggests surveying waterborne diseases. By comparing all such information it is possible to evaluate a city's difficulties and suggest environmental policies that would improve quality of life. Another example refers to the Urban Planning and Design theme. It suggests raising indicators relative to deforested areas and protected reserves. Again, the environmental aspect of city planning would improve quality of life.

Experiences of participative democracy worldwide have shown that when civil society is involved in the city administration decision-making process, residents are able to monitor government actions and act in their collective interest.

In this regard, the indicators constitute a valuable instrument so that civil society is able to evaluate the strengths and the weaknesses of cities

and thus exercise social control. Contributing to construct an effective governance participation regime improves the public administration quality, significantly and correspondingly living conditions. In the Sustainable Cities Programme, the indicators should be inserted in the indicators management platform (Iota) that enables data to be reviewed and reused through open technology standards. The quality of life of city residents, social policies and municipal public administration could be monitored in stages and yearly so that civil society and public administrators would have the tools needed to prioritize, jointly, public policy goals and the resources needed to achieve them to have a fair and sustainable city.

After evaluating the importance of the indicators, finding out how to build them, and examination of the city's reality, the next step is to prepare a Plan of Goals. The goals should be established according to the city's reality, with a vision to overcome challenges and identify ways leading to a desired future. A well-prepared Plan should always consider execution time, the benefiting or impacted territory, the Plan's formulation and impact on several administration areas, its cost and budget forecasting, its permanence and validity also within medium and long terms.

Therefore, the Sustainable Cities Programme suggests the creation of Municipal Observatories<sup>3</sup> to think of a process for following up and evaluating the performance of the Plan. On the other hand, the indicators from each city and from the Municipal Observatories support the technical and political actions of those involved and thus contribute to the democratic advancements. Formally, an observatory may be a government body, part of a university's structure or a non-governmental organization. Alternatively, it may be constituted in a mixed form or by an independent association or a set of associations with collective interests. Nevertheless, city governments will, thereafter, organize their own observatories, preferably managed by a council in which sectors of civil society, universities and public bodies participate.

Brazil's southern city of Porto Alegre is a good example of a well-functioning observatory, known as ObservaPOA. Porto Alegre is a signatory to the Sustainable Cities Programme. ObservaPOA was created in 2006 and hosts an ample georeferenced database on the city, which helps to consolidate the citizen participation in the city's administration. ObservaPOA also makes available indicators capable of qualifying the participative administration (municipal councils and local solidarity governance) under three perspectives: (1) social – impacts on the improvement of the quality of life and coexistence among people; (2) administration – impacts on efficacy, transparency and decentralization of the municipal administration; (3) politics – impacts on the democratic development and citizenship, increase in the capital and recovery of the local identity.

The Sustainable Cities Programme is a proposal assuming a change in Brazil's political culture once it considers an agenda where sustainability appears as a transversal axis of actions and initiatives, creating a systemic approach able to verify the interactions existing in the economic, social, cultural, technological fields, among others. The Programme provides



the local government with the tools necessary for consolidating its planning in an open and participatory manner. This includes searching for information and building the city's indicators, the consummation of open observatories composed by these indicators and the availability of successful national and international experiences and could be replicated in other cities.

Systematically, the Sustainable Cities Programme makes the following tools available:

- Sustainable Cities Platform - agenda for sustainability of the cities that attends to the different public administration areas, in 12 thematic foundations and includes, the social, environmental, economic, political and cultural dimensions, in an integrated manner
- Basic and general indicators associated with the platform foundations
- Good Practices – Exemplary cases and national and international references of excellence in public policies reflecting on the status of the cities' indicators
- Sustainable Public Administration Guide - 12 videos and one publication to support the implementation of the Sustainable Cities Programme
- Guide for the Use of the Indicators System for Building the Observatories – publication used in the qualification of the technicians and public administrators
- Currently, there are 273 signatory cities, making diagnosis of its cities and undertaking goals based on a minimum set of basic indicators.

## Issues, Controversies, Problems

On evaluation of the initiative, noticeable progress has been registered in the way cities involved in the Programme have organized available information. However, more time is needed to implement the work more broadly. With a little more than three years in existence, the Programme is still relatively new, mainly with regard to the change in the political administration model so firmly established in Brazilian culture.

There are several examples of cities worldwide that have undergone such change. One is Angers, in France. This city of 150,000 inhabitants boasts one of the most important mechanisms of public participation in and control of city government. The city has more than 1,500 non-governmental organizations working to improve residents' control of public policies and the rendering of accounts in the so-called shared administration. In this process, a document defining the relation between public municipal authorities and city residents, as well as their mutual commitments, was developed.

Among the Brazilian cities some stand out for embarking on this change. One of these is Canoas, in the State of Rio Grande do Sul. The city launched the *Ágora em Rede*, which is a virtual<sup>4</sup> tool enabling online dialogue between residents and administrators. *Ágora* also allows for discussion forums, chat spaces, accesses to video, among other multimedia facilities for interaction on issues concerning the city.

In view of these examples of open, participative and transparent governance, it is important to compare that with the setbacks of cities

which have failed to honour their commitments to the Sustainable Cities Programme. The fulfilment of commitment to the Programme is particularly difficult, especially in Brazil where the tradition of a representative political system is significantly less laborious than that of the participative type. However, the need for change in behaviour and the obligations for all residents to assume joint responsibilities make for ready acceptance of the Programme by public officials and city residents.

The Programme is also an initiative of civil society and does not depend on financial support from public authorities. Rather, it seeks private financing to develop and maintain its projects. There are companies that are now aware of the importance of being involved in the stimulation of sustainable development of their cities. This realization is due to social movements and other organizations supporting the cause. Currently, 53 social movements of Brazilian and other Latin America networks partake in the survey of indicators and in society's control of city administration.

There is the understanding that it is essential to expand such an initiative to other Brazilian cities that have not committed themselves to the Programme. The expansion of this programme would require its constant adaptation, as well as that of the team, which would make the effort more expensive. Efforts so far to present, mobilize and popularize the initiative and provide 5,564 cities with tools needed to implement the Programme has been a huge challenge.

## Solutions and Recommendations

With regard to the survey of indicators, the systematization and insertion of basic information into the Sustainable Cities Platform by city governments emphasizes a new work routine for public administrators. Usually, Brazilian local public administrators do not plan, systemize and analyse data generated by past and present administrations. Yet strengthening the planning and using data, goals and indexes in public administration is precisely the objective of the Sustainable Cities Programme's Indicators System. The concept of the Programme is that in order to develop any planning process and suggest changes, modifications and alternatives to local public policies, the territory, the population profile, as well as the qualitative and quantitative indicators of the developed policies must be known.



EXPERIENCES OF PARTICIPATIVE DEMOCRACY WORLDWIDE HAVE SHOWN THAT WHEN CIVIL SOCIETY IS INVOLVED IN THE CITY ADMINISTRATION DECISION-MAKING PROCESS, RESIDENTS ARE ABLE TO MONITOR GOVERNMENT ACTIONS AND ACT IN THEIR COLLECTIVE INTEREST.



Thus, the Programme is an important tool with which to strengthen the “new culture” of public administration, once information and public data are consolidated and systematized for upload into the Programme’s Indicator System. Besides the benefits that local administrators derive from information systematization fed into the Platform, the System also enables analysis of the indicators within and among cities, and with the reference indicators – established by international agencies or federal departments as values to distinguish local indicators.

Additionally, the System also enables the public administrator to make comparisons and analyses over years, once the System enables the insertion of an historical series of data and indicators. As a result, when a term of office elapses at City Hall, which in Brazil lasts four years in the case of executive offices, the administrators and the public can review the achievements and failings of that period of local government and reset priorities for the incoming administration.

In analysing comparative data among cities and within a particular city, guidelines should be determined to enable the administrator to set priorities and for the public to demand action in the spheres needing attention. In view of the aforementioned, the team has tried to get local administrators and technicians to make good their commitments to the Programme. Once the city government understands how the data feed method works and becomes familiarized; then the government’s team would understand the importance of the information that could be gathered and how this would help in decision-making. According to Ladislau Dowbor, what counts “is not only to produce significant indicators for the population, but also to provide ourselves with communications instruments of these indicators that actually allow the appropriation” (PNUD/UNDP, 2013). The training relies on pedagogic and informative materials developed as videos and booklets, about each one of the 12 Thematic Foundations and for the Programme in general, divided into theoretical and technical training phases

However, no local articulation is possible unless there is sufficient knowledge of the city’s reality; thus, the insistence on generating open information based on society’s wishes. Participatory decision-making will only be feasible in such a manner.

Therefore, initially, the city administration needs to be committed to the Programme and to be accountable to the public. The Programme encourages civil society participation in decision-making and in following up and evaluating public policies and the commitments of mayors. This is one of the reasons for making available the Sustainable Cities Platform in open data format. Even if public participation is not ensured, there are mobilization and disclosure measures aimed at expanding the involvement of the cities participating in the Programme proposal. In addition, the growing number of cities committed to the initiative expressed satisfaction with the results obtained with implementation of the Programme.

This means that the tools and instruments developed so far have been reliable for monitoring and inspection by civil society as well as for significantly improving the capacity and the quality of public



**Training Session of the Sustainable Cities Programme in the City of Colatina, Espírito Santo.**

administration. Thus, the cooperation for transparent administration, as spelled out under the Federal Law on Access to Information No. 12.527/2011, is feasible.

## Future Research and Operational Directions

Due to growing computerization and increase in Internet connectivity, a large number of persons have been motivated to seek information through this medium. The agility and possibility of interaction provided, as well the data availability, are among the advantages of this medium. Certainly, people have become more aware of their rights and duties, and have started to pressure governments to keep their promises. On the other hand, computerization and communications information technology helps governments to respond to public demand in a prompt and transparent manner.

Along these lines, the Our São Paulo Network is producing new tools to encourage transparency and democracy in the administration of public policies and for citizens’ participation.

One of the tools for citizen participation is the website “Keeping an Eye on the Goals”. It is one more instrument with which to monitor application of public policies and budget execution so that a significant part of the population becomes aware, interacts and evaluates the municipal policies, their impacts and results during an administration’s four-year cycle. The Plan of Goals should be monitored. This website will have a “Goal Monitoring and Follow-up System” so that civil society and individuals can keep track of local government’s goals and actions. The Follow up System will also have a facility to help civil society run its campaigns based on data obtained and stored in the Follow-up System. The project has already been replicated in the countries associated with the Latin American Network for Fair, Democratic and Sustainable Cities and Territories.

Figure 4. The Website “Keeping an Eye on the Goals”

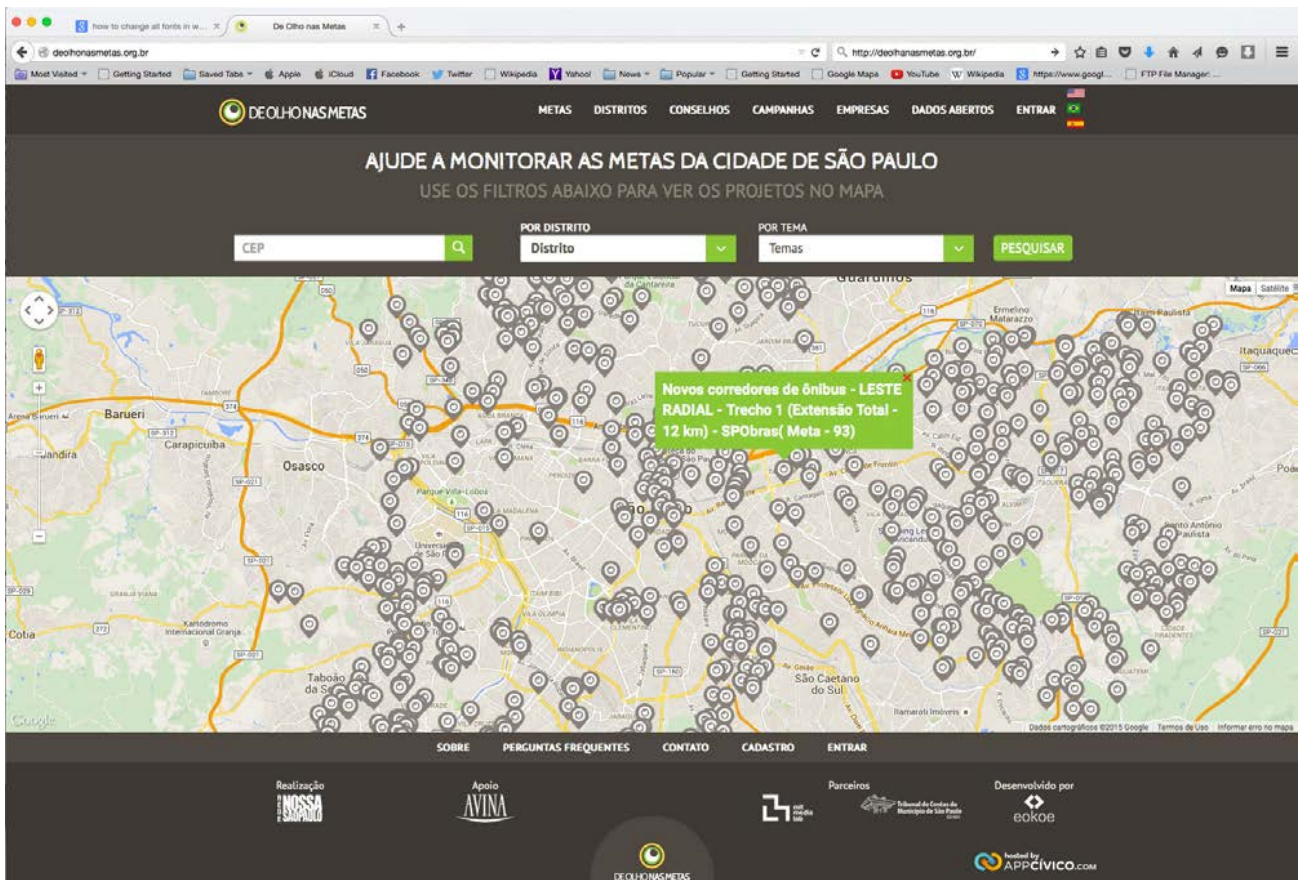

Follow-up Systems as mentioned above attempt to overcome the challenges associated with providing transparent data and its control by society. One of these challenges is sharing information with that part of the public that may be unaware of goals set by public administrators. Another challenge is to inform the public that does not understand the impact of political actions or, even if aware, may not know how to question or contribute to the actual implementation of the goals and promises made. Another challenge is to find ways to enable civil society organizations contribute to the dissemination and encourage active public commitment to relevant themes and issues. However, the greatest challenge is to discover ways to use new technologies and social media to create public awareness, inclusion and participation, since low-income people have less access to the digital world and grassroots organizations lack the tools to do their job in a more comprehensive and effective manner.

### First Changes - Initial Impact

The Sustainable Cities Programme has created positive change which has ensured its potential to impact cities, positively. In view of this, 57 cities will be participating in the Sustainable Cities Award, which will recognize the best observatories. Before the Programme was launched,

only Porto Alegre had an observatory whose data was available to the public. So far, 44 cities have loaded their Plan of Goals into the Programme's data platform; and the cities of Barueri and Campinas have set up committees to monitor commitments made by their mayors. Another important achievement is that the city of Petrópolis has created its local indicators, due to the Programme.

Currently, the 273 signatory cities that have signed the Letter of Commitment to the Programme account for 45 per cent of Brazil's gross domestic product and 34 per cent of the country's population. In addition, the Programme has spread beyond Brazil's borders. Recently, it was launched in Asunción, the capital of Paraguay.

### Conclusion

Our São Paulo Network was created because Brazilian politicians, public institutions and democratic ideals lost credibility with citizens. So, in order to restore sustainable development, ethics and participative democratic values for society, Our São Paulo Network consolidated itself as an organization, among others, with a proposal to strengthen the voice of a broad field of social actors in order to attain common objectives.

Now, many Brazilian cities have submitted civil society initiatives to fight corruption, control public spending and evaluate the quality of government programmes. Thus, the relationship between democracy and economic efficiency, as well as technical and political decisions, are drawing closer in Brazil. This is due to the recent social and political progress derived from the understanding that the country's political culture can only be changed and social justice achieved by empowering civil society, social organizations and city councils with the technology to exercise a watchdog role in city government, and intervene in public policy administration. Viewed as such, the development of tools able to make available indicators, disseminate information, map, qualify and strengthen the participatory bodies on an accessible basis becomes essential to social networks and non-governmental organizations seeking to increase their participation in the decision-making processes for political and social changes, as well as on sustainable development.

The Sustainable Cities Programme has been created out of huge social, political and reputational capital obtained by RNSP. Such capital is composed of a large social, business and academic network; the Brazilian Social Network for Fair and Sustainable Cities; as well as a substantial relationship with all political parties and the media. In order to complete this social and political capital, the Sustainable Cities Programme developed huge technical capital and knowledge in the Good Practices Database, News Portal, and the Contents and Indicators Library. This has made the Programme a source of information for the media, society and governments in the formulation and implementation of public policies.

Within this context, what is important is creation of the platform and its software geared to the collection, systematization and dissemination of information in several Brazilian cities. Aiming at gathering all such qualified information and implementing the creation of an observatory, the Sustainable Cities Programme (makes open software free to the public through a website, and thus supports the technical and political action of those involved. For the first time, in 2014, the Network launched the Sustainable Cities Award, nationally. The objective was to encourage public administrators to create, maintain and update observatories in their respective cities. These observatories were to

contain indicators, programmes of goals and relevant information on public policies on the quality of life and sustainable development, as well as recognizing and valuing positive experiences. The award categories will be for small, medium and large cities as well as metropolises.

Democracy recommends values such as equality, human dignity, participation and representation. Brazil is completing its redemocratization cycle, although much progress still needs to be made in social participation. "The city is the most constant attempt, and as a whole the most successful one already made by man, to renew the world where man lives according to their wishes, but if the city is the world that man created; it is also the world where man is condemned to live from now on. Thus, indirectly and without clearly noticing the nature of his venture, when man constructed the city he renewed himself". (Park, 1972, Page 3)

The purpose of the Sustainable Cities Programme is to contribute, with public municipal administrations, to the improvement in the quality of life and to modernize public administration by adopting planning methods able to generate good results within the short, medium and long terms.

Civil society in dozens of Brazilian and Latin American cities has been trying to provide cities with modern and efficient planning, administration and instruments for the execution of more transparent, democratic and participative public policies. The Programme is the sum of such efforts and acquired knowledge. Ideally, all these instruments should be appropriated by public authorities due to the importance of the indicators and Plans of Goals gathered in municipal observatories. These observatories are capable of providing the public with information that shows, qualifies and makes one aware of reality, problems and progress.

Cities are societal trendsetters, so actions to improve quality of life begin in them. Therefore, it is in cities that the political and social vision provided for in the Federal Constitution to achieve sustainable development and governance can be consolidated. Co-responsibility in coding ethics for public administrators can help this process.

## References

- India - Central Government. (2008). e-Governance: Conceptual Framework. Available from [http://arc.gov.in/11threp/ARC\\_11thReport\\_Ch2.pdf](http://arc.gov.in/11threp/ARC_11thReport_Ch2.pdf).
- Park, Robert (1972). *On Social Control and Collective Behavior*. Chicago: Chicago University Press.
- PNUD (Program das Nações Unidas para o Desenvolvimento) (2013). Atlas Brasil 2013 – Desenvolvimento Humano em debate. Series: Ladislau Dowbor. Available from <http://www.pnud.org.br/Noticia.aspx?id=3771>.
- UN-Habitat (2012). State of the World's Cities 2012/2013. Prosperity of cities. Available from <http://mirror.unhabitat.org/pmss/listItemDetails.aspx?publicationID=3387>

## Footnotes

1. For reading the whole Amendment, access <http://www.nossasaopaulo.org.br/porta/arquivos/programasdemetas/lei-plano-de-metas-sao-paulo.pdf> >.
2. PCS's Good Practices Database: <http://www.cidadessustentaveis.org.br/boas-praticas>.
3. In order to understand better the functionalities of the platform regarding indicators and creation of Observatories, access: <http://www.cidadessustentaveis.org.br/downloads/arquivos/guia-uso-sistema-indicadores.pdf>
4. The website is available at <http://www.canoas.rs.gov.br/site/noticia/visualizar/id/118245>.







# E-Participation Readiness in Developing Countries

○ Susanne Sonntagbauer  
Cellent AG, Active Solution Ingenieurbüro AG, Austria

○ Peter Sonntagbauer  
Cellent AG, Austria

## Abstract ○

The FUPOL research project has implemented a number of pilots in Europe, Asia and Africa. Its success has raised a lot of interest from countries around the world and it was considered necessary to elaborate a methodology, which provides a first assessment of success factors in a country for the implementation of e-participation. Urban indices, the e-government indices of the United Nations, the Human Development Index and the Democracy Index have been analysed to evaluate their capabilities to provide such a forecast.

It is argued that a success indicator has to bear in mind two aspects, namely the general readiness of a political system to take citizen opinion into account and the technical capabilities. The United Nations E-Participation Index does not fully allow forecast of the potential success of an E-Participation project. The main reason is that it measures mainly technical sophistication of the participation tools and not the political readiness. Therefore additional parameters need to be considered.

### Keywords:

E-participation, e-governance, e-government, FUPOL (Future Policy Modelling), E-Participation-Index, EIU Democracy Index, Human Development Index.



## Introduction

Within the FUPOL project a number of pilots in Europe, Asia and Africa have been implemented successfully, which has raised worldwide interest. Hence a new approach, which provides success factors in a country for the implementation of e-participation has to be designed to predict the outcome in advance. Ideally, these indices must be measured on an annual basis by an international organization. They should provide a first insight into the extent a country fulfils the necessary preconditions to successfully implement the FUPOL software and methodology.

The focus of the book is urban e-governance. This is why urban indices and data have been examined at the beginning to check their suitability.

The underlying assumptions are that in order to implement e-participation successfully the following is required:

- Technical capabilities and “e-infrastructure”,
- Freedom of expression and the Internet
- Democratic processes, which allow for the opinions of citizens to be taken into consideration when making political decisions

Therefore, the first group of potential success factors to be evaluated include the technical capabilities and the e-infrastructure of a country. In this context, the ranking of e-government and e-participation by the United Nations is an important measurement to describe the “E”-efforts of a government.

The second and probably more important group of indicators measure the maturity of the democracy, citizen centricity, political ambition and the human resources of a country. In addition, the overall development level of countries plays an important role because it somehow drives the citizens’ priorities. A well-known index in this domain is the Democracy Index of the Economist Intelligence Unit. The assessment of the Freedom House describing the freedom status of a country, its Internet and press, have also been considered.

This article contains the following structure, namely the:

- FUPOL project,
  - because it provides all relevant processes and ICT features for the implementation of e-governance and e-participations and
  - because it illustrates that technical readiness and political willingness, are essential for the success of an e-governance and an e-participation project
- Focus group developing countries,
  - because the regional scope has to be identified
- Urban indices,
  - because they are required to underline the urban focus of the book
- Indices of the United Nations, the Human Development Index, the EIU Democracy Index and the Freedom House Assessment,
  - because the urban indices are not suitable
  - because they offer convergence for a specific country although they are on a national level
- Potential usage of the indicators,
  - because the assessment of the success factors has to be further explained

STRUCTURE OF THE CHAPTER	REASON
FUPOL Project	it provides all relevant processes and ICT features for the implementation of E-Governance and E-Participation and it illustrates, that technical readiness and political willingness are essential for the success of an E-Governance and an E-participation project.
Focus Group Developing Countries	to identify the regional scope.
Urban Indices	to underline the urban focus of the book.
E-Government Indices of the United Nations, the Human Development Index, The EIU Democracy Index and the Freedom House Assessment	they provide the best approximation for a country as the urban indices are not suitable.
Potential Usage of Indices	to further outline and explain the assessment of the success factors

This chapter primarily targets policymakers, politicians, civil servants, interest groups and associations involved in influencing policy decisions, researchers dealing with e-governance, e-government, e-democracy and e-participation, experts in international organizations and development banks dealing with policy design, non-governmental organizations and consulting companies involved in governance, citizen participation, policy design and project implementation, and private sector companies.

## Scope of the topic

Before explaining and discussing the prosperity and success of e-participation in developing countries, it has to be first explained what e-government, e-governance and e-participation in this specific context means, and which nations and regions are considered. The FUPOL project will be described next to explain the generic e-governance process and technical features proposed. This is important to understand the subsequent section on potential success factors.

## E-Government and E-Governance

E-governance is synonymous with “electronic” or technology driven government. E-governance is the application of information and communication technology to provide government services in a convenient and transparent manner. The target groups are citizens, the business sector and governments itself (COMESA, E-Government Portal).

E-governance should not be mixed up with e-government. E-government is actually a narrower concept focusing on the development of specific services such as e-procurement, e-health, e-tax and e-participation. E-government is a one-way protocol whereas e-governance is a two-way-communication protocol. The essence of e-governance is to reach the beneficiary and ensure that the services intended to reach the desired individual have been delivered. The United Nations Educational, Scientific and Cultural Organization (UNESCO) defines e-governance as, “the public sector’s use of information and communication technologies with the aim of improving information and service delivery, encouraging citizen participation in the decision-making process and making government more accountable, transparent and effective” (UNESCO, 2014).

The FUPOL project encompasses the whole policy life cycle combined with ICT features to support the e-governance processes in a country, which will be described afterwards.

## E-participation

E-participation is the generally accepted term referring to “ICT-supported participation in processes involved in government and governance”. The processes may refer to all types of public services and policy decision-making. For the United Nations Public Administration Network (UNPAN), the promotion of the citizen participation is the cornerstone of socially inclusive governance. The aim of all e-participation activities should be the improvement of the citizen’s access to information and public services and the promotion of citizen’s participation in policy decision-making, which impacts the well-being of the society and the individual” (United Nations e-Government Survey 2012. E-Government for People, 2012). A more detailed definition from Macintosh sees e-participation as “the use of information and communication technologies to broaden and deepen political participation by enabling citizens to connect with one another and with their elected representatives” (Macintosh, 2004). This definition includes, as well as those of the United Nations Public Administration Network, all stakeholders in democratic decision-making processes as, for instance, citizens, civil servants, political parties, and interest groups.

E-participation processes may concern administration, public services, decision-making and policymaking. It is deemed important that the whole policy life cycle - beginning from the identification of a policy issue up to the monitoring and evaluation of the implementation of the measure - has to be accompanied by e-participation. By this means all relevant stakeholders, for example citizens, companies and civil servants are enabled to comment during the individual steps of the policymaking process to improve policy acceptance. This methodology is supported in the FUPOL project being described in the subsequent chapter.

## FUPOL-supported E-Governance and E-Participation in the Urban Context

The FUPOL project and its ICT features are described to create an understanding of ICT-supported e-governance and e-Participation. FUPOL is a research project funded by the seventh framework programme of the European Union with a budget of EUR 9 million. Its main research focus is concentrated on new technologies and methods for e-governance, e-participation and policy modelling in the urban context. The outstanding characteristic of FUPOL is the advanced policy life cycle, which is divided into main and subtasks. This detailed breakdown allows linkage of each task to various technical features.

### The FUPOL Policy Life Cycle

The FUPOL policy life cycle supports all levels of participation, such as

- “information”, which is a one-way communication process where the government or the policy distributes information to the stakeholders
- “consultation”, which is a two-way communications process that allows feedback from the citizens and other stakeholders based on issues previously defined by the government

- “active participation”, which is a partnership cooperation between the government and all relevant stakeholders (citizens, companies). The stakeholders are involved in the decision-making process, respectively in the design of the policy document, and in the implementation and evaluation of the policy measures
- “passive participation”, to find out the citizens opinions about specific topics by trawling of media, social media, blogs etc.

The FUPOL policy process can be divided into the following generic stages: agenda setting, analysis, policy formulation and policy creation, decision-making, policy implementation, as well as policy monitoring and evaluation.

Figure 1 shows the overall process and the link between each stage of the policy life cycle and its subdivision into single elements in relation to the main tasks and subtasks.

## Major Phases of the Policy Life Cycle

A brief overview of the main stages of the FUPOL Policy Life Cycle is provided below. Those are important, because they are required to understand the impact on e-participation, if certain conditions are not fulfilled.

### Agenda Setting

Policy issues can be divided into two categories: those that are already on the public policy agenda, and those that are not. If an issue is already on the public policy agenda, it has a sufficiently high profile, and a formal process to elaborate further on it is likely to be in place. If an issue is not on this agenda, electronic tools (among other channels) can be used to identify them quickly.

### Analyse

The analysis stage is determined to identify the challenges and opportunities as well as the solution approaches linked to the identified policy problem. In the analysis phase, knowledge and evidence has to be collected from a broad variety of sources.



E-GOVERNANCE SHOULD NOT BE MIXED UP WITH E-GOVERNMENT. E-GOVERNMENT IS ACTUALLY A NARROWER CONCEPT FOCUSING ON THE DEVELOPMENT OF SPECIFIC SERVICES SUCH AS E-PROCUREMENT, E-HEALTH, E-TAX AND E-PARTICIPATION. E-GOVERNMENT IS A ONE-WAY PROTOCOL WHEREAS E-GOVERNANCE IS A TWO-WAY-COMMUNICATION PROTOCOL.



Figure 1. Overview FUPOL Policy Life Cycle

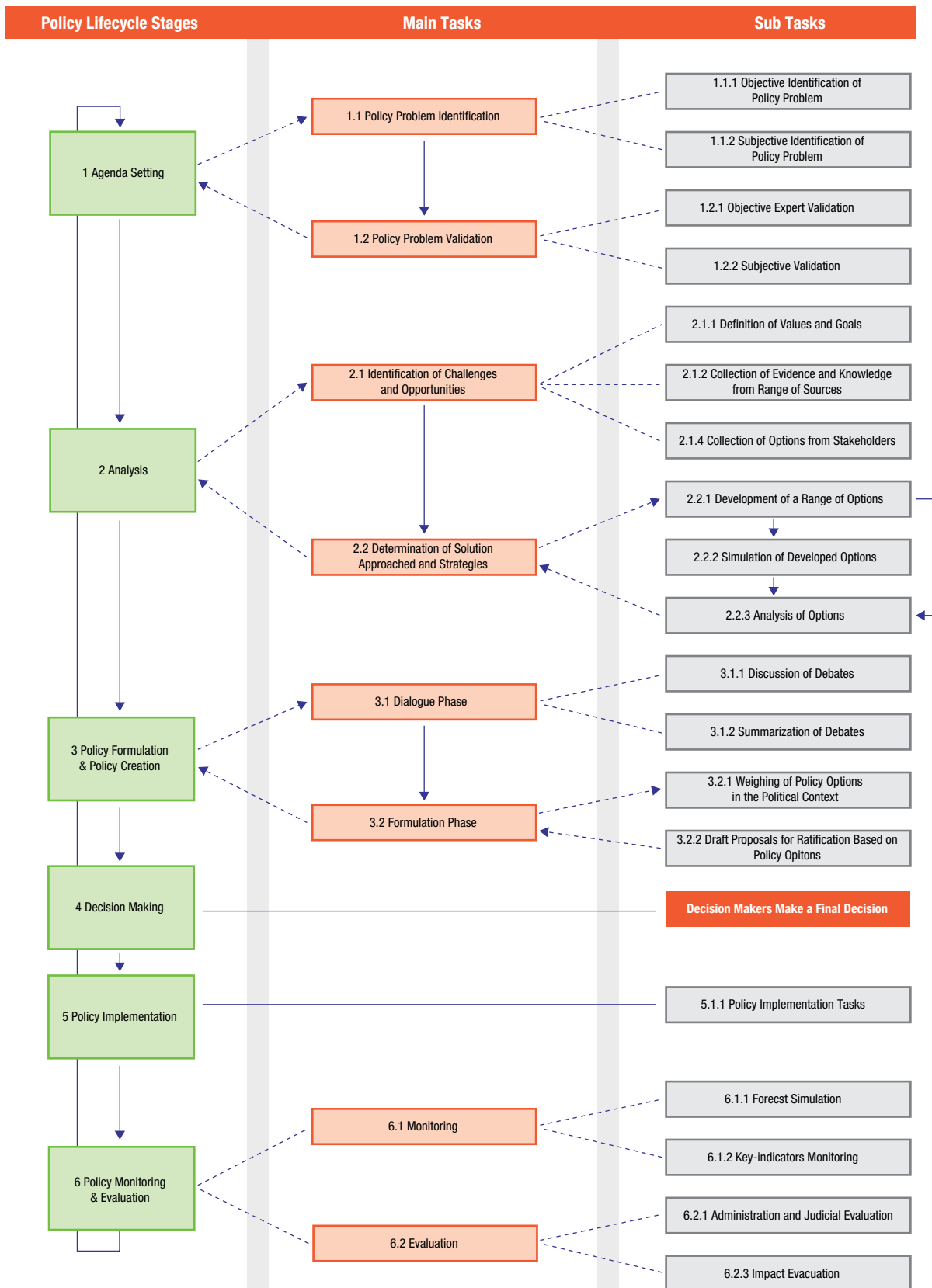

## Policy Formulation and Policy Creation

Policy formulation and creation aims at drafting proposals for ratification based on policy options. This phase establishes a stakeholder dialogue for reaching a consensus based on the analysis of the options and finally chose among the various alternatives. In addition to formal consultations, risk analysis and pilot studies, fine-tuning and evaluation of the intended policy in the current legal, organizational and political should guarantee a good workable policy document.

## Decision-making

It is the domain of the policy decision maker.

## Policy Implementation

Policy implementation inspires little interest among the general public, unless it fails. That is why the implementation process should be accompanied by citizen participation to guarantee a transparent, cooperative and successful effort.

The implementation tasks comprise all activities required to implement the policy. These tasks include the creation or provision of organization and the establishment of regulatory and legal frameworks to support the actions. Hence implementation has many facets and, therefore, cannot be described extensively. It includes tasks such as budgetary measures, public relation actions, organization changes and staff recruiting.

## Policy Monitoring and Evaluation

This phase encompasses evaluation and review of the policy in action, research evidence and views of users. Afterwards there is the possibility to loop back to stage one.

## Technology Features and their Assignment to Subtasks

The various FUPOL features and technologies, namely data integration and storage, unified integrated user interface, policy indicator dashboard, social network aggregation and single window display, hot topic sensing and topic summarization, community feedback platform, visualization of statistical data, visual social data analysis, knowledge database and visualization, outgoing multichannel social media single window messaging, opinion maps, simulation and impact visualization, and visual fuzzy cognitive maps can be used in several subtasks of the policy life cycle process.

These set of FUPOL software features represent a toolkit that support the integration and implementation of the overall policy life cycle.

Table 1 below contains an overview of the FUPOL features and their linkage to the whole FUPOL policy life cycle. It is important to integrate e-participation in the whole policy life cycle to enable stakeholder supported urban policy design.

## Basic Conditions for Successful E-participation

The FUPOL e-governance process described requires the following framework conditions to guarantee successful e-participation implementation, namely:

- Freedom of expression and the Internet
- Democratic processes, which allow that opinions expressed by citizens are taken into consideration in political decisions
- Technical capabilities and "e-infrastructure"

Examples of why the above mentioned conditions are important are explained in the following section.

The FUPOL ICT-features social network aggregation and single window display, hot topic sensing and topic summarization, opinion maps, community feedback platform and outgoing multichannel social media single window messaging are entirely dependent on the freedom of Internet.

Social network aggregation, for instance, is the process of collecting content from multiple services such as Facebook, Twitter, Blogspot or the FUPOL opinion map and pulling them together into a single location. This also includes the same channel with different accounts (e.g. Facebook pages). The postings are displayed "single window", which means postings from various sources are displayed on the same screen. This feature is mainly used in the "agenda setting" phase for the policy problem identification and verification, in the analysis phase and in the policy formulation and creation phase for discussions and debates.

Hot Topic Sensing and Topic Summarization is a web and social network analytics tool that evaluates data from social networks, identifies relevant topics and supports the FUPOL Policy Life Cycle in the agenda setting phase, in the policy formulation and creation phase to summarize debates, and during the policy implementation phase.



Asian Businesspeople working outdoor - they are sitting with a laptop in a cafe and brainstorming. © Shutterstock/Kzenon

**Table 1** Policy Life Cycle, Subtasks and Assigned Technologies

POLICY LIFE CYCLE	POLICY INDICATOR DASHBOARD	SOCIAL NETWORK AGGREGATION AND SINGLE WINDOW DISPLAY	HOT TOPIC SENSING & TOPIC SUMMARIZATION	OPINION MAPS	KNOWLEDGE DATABASE AND VISUALIZATION	VISUAL SOCIAL DATA ANALYSIS	VISUAL FUZZY COGNITIVE MAPS	VISUALIZATION OF STATISTICAL DATA	COMMUNITY FEEDBACK PLATFORM	OUTGOING MULTICHANNEL SOCIAL MEDIA SINGLE WINDOW MESSAGING	SIMULATION AND IMPACT VISUALIZATION
<b>Agenda Setting (1)</b>											
<i>Policy Problem Identification (1.1)</i>											
Objective Identification of Policy Problem (1.1.1)	X							X			
Subjective Identification of Policy Problem (1.1.2)		X	X	X		X					
<i>Policy Problem Validation (1.2)</i>											
Objective Expert Validation (1.2.1)					X			X			
Subjective Validation (1.2.2)		X	X			X					
<b>Analysis (2)</b>											
<i>Identification of Challenges and Opportunities (2.1)</i>											
Definition of Values and Goals (2.1.1)					X						
Collection of Evidence and Knowledge from a Range of Sources (2.1.2)					X			X			
Collection of Opinions from Stakeholders (2.1.3)		X		X		X					
<i>Determination of Solution Approaches and Strategies (2.2)</i>											
Development of a Range of Options (2.2.1)					X		X		X		
Simulation of Developed Options (2.2.2)											X
Analysis of Options (2.2.3)					X						
<b>Policy Formulation &amp; Policy Creation (3)</b>											
<i>Dialogue Phase (3.1)</i>											
Discussions and Debates (3.1.1)		X		X		X			X	X	
Summarization of Debates (3.1.2)			X							X	
<i>Formulation Phase (3.2)</i>											
Weiing of Policy Options in the Political Conext (3.2.1)											
Draft Proposals for RatificationStage Based on Policy Options (3.2.2)											
<b>Decision Making (4)</b>											
<b>Policy Implementation (5)</b>											
Policy Implementation (5.1.1)		X	X	X					X	X	
<b>Policy Monitoring &amp; Evaluation (6)</b>											
<i>Monitoring (6.1)</i>											
Forecast Simulation (6.1.1)											X
Key Indicators Monitoring (6.1.2)	X							X			
<i>Evaluation (6.2)</i>											
Administrative and Judicial Evaluation (6.2.1)											
Impact Evaluation (6.2.2)								X			

Opinion maps are interactive electronic charts that can be integrated into almost any internal or external website and allow citizen to give their opinions georeferenced. The maps support the agenda setting, analyse, policy formulation and creation, as well as policy implementation phases.

The Community Feedback Platform is inspired by crowdsourcing platforms and is designed to enhance cognitive processes in a similar vein as traditional idea management systems. The purpose of the system is to facilitate the idea analysis and selection processes. It supports the analyses phase to develop a range of options, the policy creation and formulation phase, and the implementation phase.

Outgoing multichannel social media single window messaging is the capability of posting messages to various channels (social media targets) at the same time without the need to manually post to each site separately. The facility is used in FUPOL's policy creation and formulation and in the policy implementation phase.

The ICT tools demonstrated above imply at least freedom of the Internet to implement an e-participation project, successfully.

Democratic processes to allow opinion expression and technical readiness are also required. As a consequence, all countries that lack these three parameters are not considered to implement prosperous e-participation projects. Technical readiness means that the required technical infrastructure is available.

## Focus on Developing Countries

The whole chapter is focused on developing countries worldwide. These countries are broadly classified into categories based on their economic development. These categories are connected to a number of criteria ranging from per capita income to life expectancy and literacy rates. There is also some criticism regarding the term "developing country", which implies inferiority to developed ones - which many countries reject. The United Nations has produced the Human Development Index, comprising the above mentions criteria, namely life expectancy, income and literacy rate for the ranking, and comparison of all countries worldwide. Countries with an HDI below 0.8 are generally considered as developing countries.

However, according to the United Nations Statistics Division "The designations 'developed' and 'developing' are intended for statistical convenience and do not necessarily express a judgement about the stage reached by a particular country or area in the development process" (United Nations Statistics Division).

In addition in the composition of macro geographical (continental) regions, geographical subregions, selected economic and other grouping say: "There is no established convention for the designation of 'developed' and 'developing' countries or areas in the United Nations system. In common practice, Japan in Asia, Canada and the United States in northern America, Australia and New Zealand in Oceania, and Europe are considered 'developed' regions or areas. In international trade statistics, the Southern African Customs Union is also treated as a developed region

and Israel as a developed country; countries emerging from the former Yugoslavia are treated as developing countries; and countries of Eastern Europe and of the Commonwealth of Independent States (code 172) in Europe are not included under either developed or developing regions". (Composition of macro geographical (continental) regions, geographical subregions, and selected economic and other groupings, 2013).

The United Nations has 193 Member States of which 53 are classified "developed" countries and 140 are "developing" countries at varying levels of advancement. Hence about three-quarters of all Member States are developing countries. The developing world comprises all countries in Africa, in Asia (except Japan, South Korea, Hong Kong, Singapore, Qatar, Brunei and Bahrein), in South America (except Chile and Argentine). Developing countries in Europe are Albania, Bosnia and Herzegovina, Serbia and the Republic of Macedonia, a successor State of the former Yugoslav.

## Indices to be considered

### Urban Indices and Data

The scope of the book is urban e-governance in developing countries. Hence we have examined the suitability of the following indices and statistical data for e-governance in cities.

UN-Habitat created the City Prosperity Index, which is a composed indicator of the Productivity Index, the Quality of Life Index, the Infrastructure Index, the Environment Index and the Equity Index (UN-Habitat, 2013).

In the State of African Cities 2014 (UN-Habitat, The State of African Cities 2014. Re-imagining sustainable urban transitions, 2014), statistics about the trends of African cities are provided, but they are unrelated to e-governance.

The United Nations Department of Economic and Social Affairs (UNDESA) allocates specific data about urban population trends (United Nations. Department of Economic and Social Affairs).

UN-Habitat has started developing and testing an Urban Governance Index. It aims to measure the progress in urban governance. The indices are not suitable, as they do not refer to urban e-governance. Hence the following indices have been examined further. Despite the fact that they are on the national level, they provide the best approximation for a specific country.

### E-Government Indices of the United Nations

Since 2003, the United Nations Public Administration Programme has been conducting annual surveys on e-government in Member States. They are particularly useful for comparison because of their worldwide coverage. They are, however, based on self-assessment of Member States (a questionnaire).

The Global E-Government Development Report and Survey presents an assessment of how governments use information and communications



technology to provide access and inclusion for all. The survey aims to inform and improve the understanding of policymakers' choices in their e-government programme undertakings. It is a useful tool for government officials, researchers, the representatives of civil society, and the private sector to gain a deeper understanding of the relative position of a country vis-à-vis the rest of the world economies (United Nations E-Government Survey 2012. E-Government for People, 2012).

### **E-Government Development Index**

The E-Government Development Index is "a composite measure of the capacity and willingness of countries to use e-government for ICT-led development. The index has been updated annually by the United Nations Public Administration Programme since its creation in 2003. The index covers all United Nations Member States and focusses on the scope and quality of online services, on telecommunication connectivity, and on human capacity (United Nations E-Government Survey 2012. E-Government for People, 2012).

### **Human Capital Index**

The Human Capital Index seeks to raise awareness of the factors that contribute to the development of a healthy and productive labour force. It is based on education, health and wellness, workforce and employment and enabling environment (United Nations E-Government Survey 2012. E-Government for People, 2012).

### **Telecommunication Infrastructure Index**

According to the United Nations, the telecommunication infrastructure index is based on six primary indices which represent the ICT infrastructure of a country as, for instance, personal computers/1,000 persons, Internet users/1,000 persons, telephone lines/1,000 persons, online population, mobile phones/1,000 persons and televisions/1,000 persons. Data are collected from the United Nations International Telecommunication Union and the United Nations Statistics Division, supplemented by the World Bank (United Nations E-Government Survey 2012. E-Government for People, 2012).

### **Online Service Index**

The Online Service Index takes into consideration the country's websites, including the nation portal, e-services and e-participation portals, as well as the websites of the related ministries of education, labour, social services, health, financial and environment (United Nations E-Government Survey 2012. E-Government for People, 2012).

### **E-Participation Index**

For United Nations Public Administration Network the E-Participation Index is a measure which focuses on "the use of online services to facilitate provision of information by government to citizens (e-information sharing), interaction with stakeholders (e-consultation) and engagement in decision-making processes (e-decision-making) (United Nations E-Government Survey 2012. E-Government for People, 2012). As such, it includes the capacity and the willingness of the government to encourage its citizen to participate in the decision-making process. A country's E-Participation Index value totally reflects how useful these features are and how well they have been deployed

by the government compared with all other countries. The purpose of this measure is not to prescribe any particular practice, but to offer insight into how different countries are using online tools to promote interaction between citizen and government, as well as among citizens, for the benefit of all (United Nations E-Government Survey 2012. E-Government for People, 2012).

### **Human Development Index (HDI)**

The United Nations developed the Human Development Index together with the Human Development Report in 1990. The index is used by the United Nations by combining indicators of life expectancy, educational attainment and income into a composite human development index (Human Development Report 2013. The Rise of the South: Human Progress in a Diverse World, 2013).

Health or life expectancy at birth is measured in the index using a minimum of 20 years and a maximum value of 83.57. In a country where the life expectancy at birth is 55 years, the longevity component will be 0.551 (Human Development Report 2013. The Rise of the South: Human Progress in a Diverse World, 2013).

The education component of the index is measured by mean years of schooling for adults aged 25 years, and expected years of schooling for children of school entering age.

The standard of living is measured by gross national income per capita, per capita purchasing power parity; instead of gross domestic product per capita (Human Development Report 2013. The Rise of the South: Human Progress in a Diverse World, 2013).

Other "soft" development factors such as political freedom and personal security are deemed important, too. However, they are not included in the Human Development Index; they are considered in the Economic Intelligence Unit's (EIU) Democracy Index.

The latest Human Development Index was released in 2013 and covers the period up to 2012. In it, 47 countries have an index – which is ranked from 0 to 1. Measures above 0.8 are classified as developed countries.

### **EIU Democracy Index**

The Democracy Index measures the state of democracy in 167 countries, of which 166 are sovereign States and 165 members of the United Nations. The index is based on 60 indicators grouped in five different categories: electoral process and pluralism, civil liberties, functioning of government, political participation, and political culture. In addition to a numeric score and a ranking, the index is earmarked by four different levels for the categorization of countries. It ranges from Level 1, comprising countries with high citizen participation in policy decision-making to Level 4 containing countries with weak political participation. The index was first produced for 2006, with updates for 2008, 2010, 2011 and 2012 (Kekic, 2012).

The index values are used to place countries within one of the four participation levels.

Most answers are “experts’ assessments”. The report neither indicates the kinds of experts nor their number, nationalities; whether they are employees of the Economist Intelligence Unit or independent scholars. Some answers are provided by public-opinion surveys from the respective countries. In the case of countries for which survey results are missing, those for similar countries and expert assessments are used in order to fill in gaps. However, this index has been selected as it has worldwide coverage regarding civil liberties and democracy, which is the cornerstone of a successful implementation of e-governance and e-participation.

## Freedom House Assessment

Freedom House is an independent organization dedicated to the expansion of freedom around the world. It was founded in 1941 by a group of prominent individuals, including journalists, scholars and politicians. Eleonore Roosevelt (wife of 32nd United States President Franklin D. Roosevelt) served as honorary co-chairperson. Freedom House “supports non-violent civic initiatives in societies where freedom is denied or under threat and promotes the right of all people to be free” (Freedom House).

Freedom House publishes a yearly survey and report, called Freedom in the World that attempts to measure the degree of democracy and political freedom worldwide. The survey ratings and narrative reports on 195 nations and 14 related and disputed territories are used by policymakers, civic activists, international organizations and the media to monitor the developments on an international basis (Puddington, 2014). The Freedom House Assessment has been chosen as it has a worldwide coverage and it is the only one focusing on freedom of the Internet.

Freedom of the World distinguishes three levels of liberty, ranging from Level 1, involving countries providing comprehensive political rights and civil liberties to Level 3, which encompasses countries where these rights and liberties are not fully implemented. The number of countries allocated by Freedom in the World in 2013 to “Level 1” stood at 88 (marked in green); to “Level 2” at 59 countries (marked in yellow); and to “Level 3” at 48 countries (marked in purple) in the Figure below (Puddington, 2014).

Figure 2. Status of Freedom Worldwide

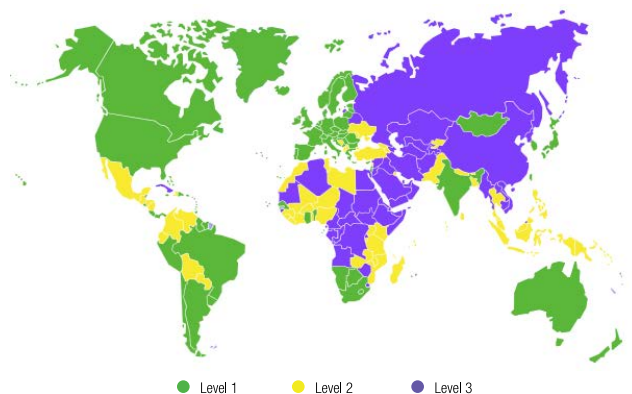

## Potential usage of indices as e-participation success factors

In this chapter at hand the potential suitability of indicators and combinations thereof will be outlined to predict a successful worldwide implementation of e-participation.

The first assumption is that the EIU participation index (Democracy Index) measures the overall maturity of political participation processes in a country, regardless of their support through electronic or conventional means.

The second assumption is that the United Nations E-Participation Index somehow measures the successful implementation of e-participation in a country and, therefore, could be used as a first indication, whether the FUPOL software and methodology can be successfully implemented.

## Indices in the Developing Countries and Worldwide Average

The tables below, one based on the United Nations E-Government Survey 2012 and another on the 2014 survey (United Nations E-Government Survey 2014. E-Government for the Future we want, 2014), show a comparison of the United Nations E-Government Indices between the developing countries (140 countries) with the world (193 countries).

Significant differences between the developing countries and the world regard infrastructure and e-participation, for which the indices differ by 62 per cent in the year 2012. In 2014, both indexes have increased. The average E-Participation Index for the developing countries shows a crucial improvement, especially compared to the worldwide index. The difference has been reduced from 62 to 26 per cent, although the index is quite low for worldwide and developing country-based levels.

The most significant shortcoming of the developing countries is the infrastructure, which is expressed by a difference of 52 per cent.

The other indices differ between 11 and 27 per cent in 2012; and between 12 and 34 per cent in 2014.

The figures show very high indices regarding human capital and human development for development countries and the whole world.

The democracy indicators show a similar picture. The overall difference between the developing countries and all United Nations Member States is significant and amounts between 13 and 21 per cent, with the highest difference regarding Functioning of government.

**Table 2** Difference Developing Countries and World for United Nations E-Government Indices 2012

	E-GOVERNMENT DEVELOPMENT	ONLINE SERVICE	HUMAN CAPITAL	INFRASTRUCTURE	E-PARTICIPATION	AVERAGE UN E-GOVERN. INDICES	HDI
Average Developing Countries	0.39	0.35	0.64	0.20	0.14	0.34	0.59
Average World	0.49	0.44	0.71	0.32	0.22	0.44	0.67
Difference	-25%	-27%	-11%	-62%	-62%	-27%	-14%

**Figure 4.** E-Government Development Index 2014

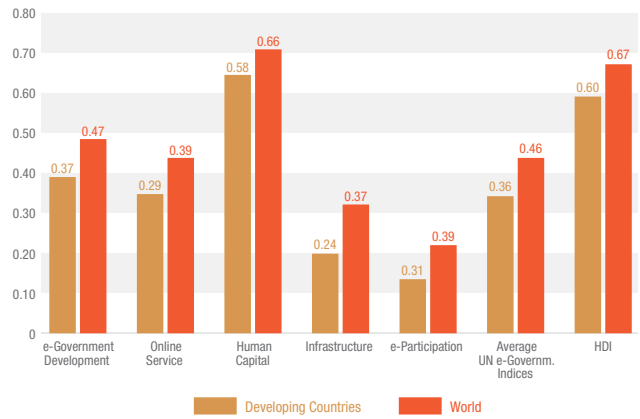

**Table 3** Difference Developing Countries and World for United Nations E-Government Indices 2014

	E-GOVERNMENT DEVELOPMENT	ONLINE SERVICE	HUMAN CAPITAL	INFRASTRUCTURE	E-PARTICIPATION	AVERAGE UN E-GOVERN. INDICES	HDI
Average Developing Countries	0.37	0.29	0.58	0.24	0.31	0.36	0.60
Average World	0.47	0.39	0.66	0.37	0.39	0.46	0.67
Difference	-27%	-34%	-12%	-52%	-26%	-26%	-12%

**Table 4** Difference Developing Countries and World for EIU Democracy Index

	ELECTORAL PROCESS	FUNCTIONING OF GOVERNMENT	PARTICIPATION	POLITICAL CULTURE	CIVIL LIBERTIES	DEMOCRACY INDEX (OVERALL EIU RANKING)
Average Developing Countries	4.99	4.08	4.24	4.86	5.30	4.69
Average World	5.96	4.95	4.78	5.48	6.15	5.46
Difference	-19%	-21%	-13%	-13%	-16%	-16%

**Figure 3.** E-Government Development Index 2012

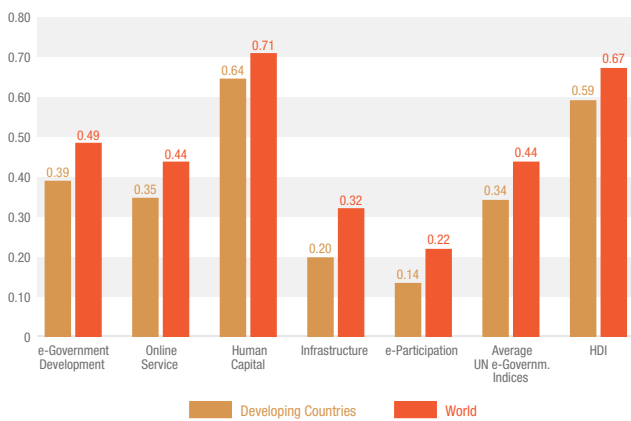

**Figure 5.** Democracy Index 2012

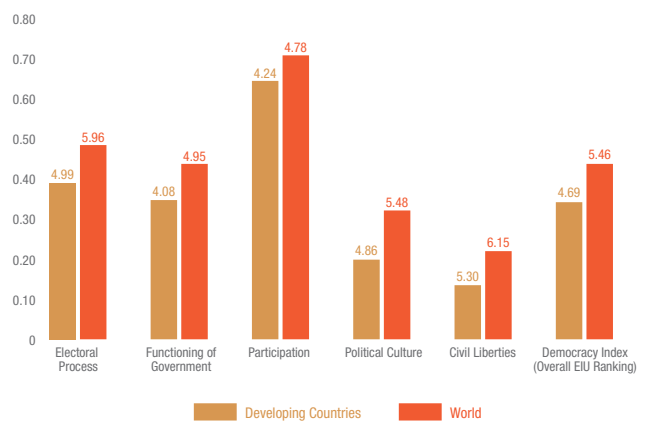

One insight reveals the average of both indicator groups. The difference in Table 5.

**Table 5** Comparison Developing Countries - World

	2012		2014	
	OVERALL EIU RANKING	UN E-GOVERNMENT INDICES AVERAGE	OVERALL EIU RANKING	UN E-GOVERNMENT INDICES AVERAGE
Developing Countries	4.69	0.34	4.69	0.36
World	5.46	0.44	5.46	0.46
	-16.40%	-27.14%	-16.40%	-26.48%

**Table 6** EIU Democracy Index and Freedom House Assessment-24 first Ranked Countries Worldwide

COUNTRY	EIU-Index 2012		Freedom House Index 2014	
	INTERNET	RANK	PRESS	INTERNET
Norway	9.930	1	1	1
Sweden	9.730	2	1	1
Iceland	9.650	3	1	1
Denmark	9.520	4	1	1
New Zealand	9.260	5	1	1
Australia	9.220	6	1	1
Switzerland	9.090	7	1	1
Canada	9.080	8	1	1
Finland	9.060	9	1	1
Netherlands	8.990	10	1	1
Luxembourg	8.880	11	1	1
Austria	8.620	12	1	1
Ireland	8.560	13	1	1
Germany	8.340	14	1	1
Malta	8.280	15	1	1
United Kingdom	8.210	16	1	1
Czech Republic	8.190	17	1	1
Mauritius	8.170	18	1	1
Uruguay	8.170	19	1	1
Republic of Korea	8.130	20	2	2
USA	8.110	21	1	1
Costa Rica	8.100	22	1	1
Japan	8.080	23	1	1
Belgium	8.050	24	1	1

Freedom House Assessment 1=Level 1, 2=Level 2, 3=Level 3

**Table 7** Democracy Index and Freedom House Assessment - 24 First Ranked Developing Countries

COUNTRY	EIU-Index 2012		Freedom House Index 2014	
	INTERNET	RANK	PRESS	INTERNET
Uruguay	8.170	18	1	1
Costa Rica	8.100	21	1	1
Cape Verde	7.920	25	1	1
Botswana	7.850	27	2	1
South Africa	7.790	28	2	1
Chile	7.540	32	2	1
India	7.520	35	2	2
Timor-Leste	7.160	39	no data	no data
Brazil	7.120	40	2	2
Panama	7.080	41	2	1
Trinidad and Tobago	6.990	43	1	1
Mexico	6.900	46	3	2
Indonesia	6.760	48	2	2
Lesotho	6.660	50	2	1
Suriname	6.650	51	1	1
Columbia	6.630	52	2	2
Thailand	6.550	53	3	2
Dominican Republic	6.490	55	2	1
El Salvador	6.470	56	2	1
Peru	6.470	56	2	1
Malaysia	6.410	57	3	2
Mongolia	6.350	58	1	1
Serbia	6.330	59	1	1
Papua New Guinea	6.320	60	1	1

Freedom House Assessment 1=Level 1, 2=Level 2, 3=Level 3

The UN "e-indicators" is much higher than in the EIU Democracy Index between the developing countries and the world. This is mainly based on the lack of infrastructure in the developing countries in 2012 and 2014. But the difference between the developing countries and the world in 2012 and 2014 is nearly the same.

## The EIU Democracy Index and Freedom House Assessment

### 24 Top Ranked Countries Worldwide

The top 24 countries ranked by the index are listed in table 6 below. The data are derived from the Democracy Index 2012 (Democracy Index 2012. Democracy at a Stillstand, 2012). The assessment of the Freedom House regarding the freedom of the press and the Internet are specified, also. (Freedom House Regions).

The ranking appears reasonable as a starting point to evaluate the potential success of FUPOL in a country. However, there are a few shortcomings of the Democracy Index. The major shortcoming is that

the methodology is based on experts and surveys. While it is relatively easy to verify whether a specific e-government component is really available, this is more difficult in the case of actual citizen participation in decision-making, democracy or civil rights. In some countries, laws describing processes and regulations could provide a good governance framework in theory, but in reality may be quite different. Consequently indices must rely partly on expert assessments, which could be biased, or on the surveys measuring the public perception. Again the latter could be wrong because typically it is not based on hard facts.

In 2012, only the developing countries of Costa Rica and Uruguay were ranked in the top 24; the majority of developing countries are allocated to Levels 3 and 4 (countries with low public participation in policy decision-making) of the Democracy Index, with weak media and Internet freedom.

The developing countries are ranked from 18 to 60 in the Democracy Index. Only eight of the 24 top ranked developing countries have unlimited Internet access and media freedom, which is a crucial barrier for a successful e-participation project.

## The United Nations E-Participation Index and the Freedom House Assessment

### Top Ranked Countries Worldwide

Table 8 shows the top 24 countries ranked by the E-Participation Index from the United Nations E-Government Survey 2012 (United Nations E-Government Survey 2012. E-Government for People, 2012), and its 2014 survey (United Nations E-Government Survey 2014. E-Government for the Future We Want, 2014). The countries are linked with the media and Internet freedom as outlined in the data pool of the Freedom House (Freedom House Regions).

The ranking in both tables contains a number of countries with partially developed and implemented democratic processes (marked in yellow and in orange): they are Kazakhstan, United Arab Emirates, Saudi Arabia, Russian Federation, Bahrain, Qatar, Morocco and Egypt. Likewise, in some countries, media and Internet freedoms are not fully ensured.

Therefore the ranking of the United Nations e-participation does not fully allow for a forecast of the potential success of an e-participation project, since the project's success would imply that:

- citizens as well as media can freely express their opinion
- Internet as the main channel of e-participation is not restricted in any way
- democratic processes are in place, which allow opinions expressed by
- citizens to be taken into consideration in political decisions

The United Nations indices and the EIU Index (up to 2010) are measuring mainly technical sophistication and availability of government online services: the greater the technical sophistication, the higher the score. The actual impact on government processes, methods, and policies is not taken into account. This means that in the case of e-participation it is not considered, whether:

**Table 8** United Nations E-Participation Index 2012 and Freedom House Assessment – 24 Top Ranked Countries Worldwide

COUNTRY	EIU-Index 2012		EIU	Freedom House Index 2014	
	INTERNET	RANK	RANK	PRESS	INTERNET
Netherlands	1.000	1	10	1	1
Republic of Korea	1.000	1	19	2	2
Singapore	0.947	2	71	2	2
Kazakhstan	0.947	2	124	3	3
United Kingdom	0.921	3	16	1	1
United States of America	0.921	3	20	1	1
Israel	0.895	4	33	1	1
Australia	0.763	5	6	1	1
Germany	0.763	5	14	1	1
Estonia	0.763	5	31	1	1
Finland	0.737	6	9	1	1
Japan	0.737	6	22	1	1
Colombia	0.737	6	52	2	2
United Arab Emirates	0.737	6	130	3	3
Norway	0.684	7	1	1	1
Sweden	0.684	7	2	1	1
Canada	0.684	7	8	1	1
Egypt	0.684	7	93	3	2
Chile	0.658	8	32	2	2
Russian Federation	0.658	8	105	3	3
Bahrain	0.658	8	131	3	3
Qatar	0.632	9	119	3	3
Saudi Arabia	0.632	9	143	3	3
Mongolia	0.605	10	58	1	1
New Zealand	0.579	11	5	1	1
France	0.579	11	26	1	1

Freedom House Assessment 1=Level 1, 2=Level 2, 3=Level 3

- the results obtained by the “e” tools are really being used in the policy design process; or
- the participation of citizens in the decision-making process has really improved after certain “e” tools have been introduced

While the practical impact of some benchmarks to push investment in countries that are lagging, the scientific value of e-government benchmarking in general and, specifically, e-participation indices is questionable. Do they really provide an accurate measurement?

Apart from the weaknesses already mentioned, the actual “take-up” by citizens is not adequately measured. In the case of e-participation this would mean, for example, a standard definition and comparable figures for the percentage of the population that has been actively

**Table 9** United Nations E-Participation Index 2014 and Freedom House Assessment – 24 Top Ranked Countries Worldwide

COUNTRY	EIU-Index 2012		EIU	Freedom House Index 2014	
	INTERNET	RANK	RANK	PRESS	INTERNET
Netherlands	1.000	1	10	1	1
Republic of Korea	1.000	1	19	2	2
Uruguay	0.980	2	18	1	1
France	0.961	3	26	1	1
Japan	0.961	3	22	1	1
UK	0.961	3	16	1	1
Australia	0.941	4	6	1	1
Chile	0.941	4	32	2	2
USA	0.922	5	20	1	1
Singapore	0.902	6	71	2	2
Colombia	0.882	7	52	2	2
Israel	0.863	8	33	1	1
United Arab Emirates	0.843	8	130	3	3
Bahrain	0.824	10	131	3	3
Canada	0.824	10	8	1	1
Costa Rica	0.824	10	21	1	1
Greece	0.804	11	30	1	1
Morocco	0.804	11	89	3	2
Italy	0.784	12	29	1	1
New Zealand	0.784	12	5	1	1
Spain	0.784	12	23	1	1
Estonia	0.765	13	41	1	1
Kazakhstan	0.765	13	124	3	3
Brazil	0.706	14	40	2	2
Finland	0.706	14	9	1	1
Germany	0.706	14	14	1	1

Freedom House Assessment 1=Level 1, 2=Level 2, 3=Level 3

engaged through “e” means in policy design and decisions. Likewise, another weakness of many e-government benchmarks is their major focus on national government. Specifically for participative processes, this is a major shortcoming since many initiatives take place in a city or municipality. The national government may not even be aware of them. Consequently, information provided by national governments may be incomplete.

### Top Ranked Developing Countries

Table 10 shows the top 24 developing countries ranked by the E-Participation Index from the United Nations E-Government Survey 2012 (United Nations E-Government Survey 2012. E-Government for People, 2012) and the 2014 survey. The countries are linked too with the Freedom House assessment regarding press and Internet freedom. (Freedom House Regions).

**Table 10** United Nations E-Participation Index 2012 and Freedom House Assessment - 24 Top Ranked Developing Countries

COUNTRY	EIU-Index 2012		EIU	Freedom House Index 2014	
	INTERNET	RANK	RANK	PRESS	INTERNET
Kazakhstan	0.947	2	124	3	3
Colombia	0.737	6	52	2	2
Egypt	0.684	7	93	3	2
Russian Federation	0.658	8	105	3	3
Saudi Arabia	0.632	10	144	3	3
Mongolia	0.605	11	58	1	1
Mexico	0.579	12	46	3	2
El Salvador	0.553	13	56	2	1
Brazil	0.500	15	40	2	2
Malaysia	0.500	15	57	3	2
Dominican Republic	0.474	16	55	2	1
Morocco	0.395	18	98	3	2
Peru	0.395	18	56	2	1
Republic of Moldova	0.395	18	60	3	3
Tunisia	0.368	19	77	2	2
Ethiopia	0.342	20	106	3	3
Costa Rica	0.316	21	21	1	1
Lebanon	0.316	21	84	2	2
Panama	0.316	21	41	2	1
Thailand	0.316	21	53	3	2
Kyrgyzstan	0.290	22	90	3	2
Venezuela	0.263	23	81	3	2
Cape Verde	0.237	24	25	1	1
Ecuador	0.237	24	74	3	2
Guatemala	0.237	24	71	2	2
Serbia	0.237	24	59	1	1

Freedom House Assessment 1=Level 1, 2=Level 2, 3=Level 3

The developing countries are ranked high in both tables – the ranking of the E-Participation Index is between 2 and 24, although the majority of these countries have weak citizen rights, Internet and media freedom. These restrictions are also reflected in the EIU Index. Of the 24 top ranked developing countries, 5 are allocated to “Level 3” regarding Internet access. This is a major barrier in the e-participation process, since a successful project of its kind requires unlimited Internet access.

### Dependencies between Components of the UN E-Participation Index, the HDI and the EIU Democracy Index – Global view

In order to further analyse the dependencies between the various indicators, cross correlations have been calculated. Orange means a correlation higher than 0.60, light orange between 0.50 and 0.60 and blue less than 0.50.



**Table 11** United Nations E-Participation Index 2014 and Freedom House Assessment - 24 Top Ranked Developing Countries

COUNTRY	EIU-Index 2012		EIU	Freedom House Index 2014	
	INTERNET	RANK	RANK	PRESS	INTERNET
Uruguay	0.980	2	18	1	1
Colombia	0.882	7	52	2	2
Costa Rica	0.824	10	21	1	1
Morocco	0.804	11	98	3	2
Kazakhstan	0.765	13	124	3	3
Brazil	0.706	14	40	2	2
Peru	0.706	14	56	2	1
Mongolia	0.686	15	58	1	1
Russian Federation	0.686	15	105	3	3
China	0.647	16	123	3	3
Sri Lanka	0.647	16	76	3	2
Tunisia	0.647	16	77	2	2
India	0.628	17	35	2	2
Republic of Moldova	0.628	17	60	3	3
El Salvador	0.608	18	56	2	1
Mexico	0.608	18	46	3	2
Georgia	0.588	20	79	2	1
Philippines	0.569	21	61	2	1
Saudi Arabia	0.569	21	144	3	3
Venezuela	0.569	21	81	3	2
Egypt	0.549	22	93	3	2
Thailand	0.549	22	53	3	2
Albania	0.529	23	77	PF	2
Armenia	0.529	23	97	3	1
Malaysia	0.529	23	57	3	2
Antigua and Barbuda	0.510	24	152	2	1

Freedom House Assessment 1=Level 1, 2=Level 2, 3=Level 3

There is a significant correlation between all indicators, well above the required significance level at 1 per cent (0.18). The highest correlation is between the Human Development Index and the United Nations "e"-indices infrastructure and various indicators of the Democracy Index. In 2012, e-participation had a correlation below 0.50 to all democracy indicators, except the Development Index. In 2014, this correlation has improved, but up to now the indicator does not measure how an offered e-participation infrastructure is actually used by the population and how it is linked to the actual policy design and decision process.

## Future Research or Operational Directions

Future research should focus on the development and further improvement of the existing UN-Habitat Urban Governance Index. This index aims to measure the extent and progress in urban governance and urban e-participation.

**Table 12** Dependencies United Nations E-Participation Index, HDI and EIU Democracy Index 2012

	E-GOVERNMENT DEVELOPMENT	ONLINE SERVICE	HUMAN CAPITAL	INFRA-STRUCTURE	E-PARTICIPATION	HDI
Overall EIU Ranking	0.66	0.60	0.51	0.69	0.44	0.59
Electoral Process	0.52	0.46	0.41	0.55	0.31	0.45
Functioning of government	0.68	0.66	0.52	0.68	0.49	0.60
Participation	0.61	0.52	0.51	0.62	0.39	0.55
Political Culture	0.59	0.54	0.42	0.65	0.43	0.53
Civil Liberties	0.57	0.52	0.45	0.59	0.36	0.52
HDI	0.80	0.71	0.71	0.73	0.56	1.00

**Table 13** Dependencies United Nations E-Participation Index, HDI and EIU Democracy Index 2014

	E-GOVERNMENT DEVELOPMENT	ONLINE SERVICE	HUMAN CAPITAL	INFRA-STRUCTURE	E-PARTICIPATION	HDI
Overall EIU Ranking	0.64	0.55	0.57	0.66	0.54	0.59
Electoral Process	0.50	0.41	0.46	0.51	0.43	0.45
Functioning of government	0.67	0.61	0.58	0.66	0.59	0.60
Participation	0.59	0.48	0.55	0.60	0.45	0.55
Political Culture	0.59	0.50	0.50	0.64	0.46	0.53
Civil Liberties	0.56	0.47	0.51	0.57	0.48	0.52
HDI	0.81	0.68	0.77	0.73	0.76	1.00

This enhanced urban index should be tested in bigger and smaller cities on a sample basis. To determine e-readiness and especially e-participation readiness for the whole policy process, the whole FUPOL policy life cycle and its ICT features could be integrated in the city questionnaire.

Future research should consider actual projects implemented in a country and their success because this is the only real evidence that an indicator or a set of indicators are a good measurement for the outcome of an e-participation project. Field research is essential to improve and validate, further, the e-participation indices.

The following principles are suggested to collect indicators about "e-participation" at the local level:

### a. Evidence based

Only indicators for which supporting evidence could be provided and checked easily should be taken into consideration.

Examples:

- social media presence of local government and politicians
- published laws and regulations

Evidence-based indicators allow for the collection of data without relying on survey questionnaires. Data derived from surveys should be minimized, because they are always a burden to respondents in local governments and hence the response rate is typically low.

#### b. Automatic data collection

It is proposed to monitor online indicators automatically. This means that software should scan predefined government websites, blogs or the social media presence of local government and politicians and logs the indicators (for example, statistics on the number of postings, updates, number of likes and fans.)

#### c. Actual Take-Up

Indicators should be included, which measure the actual take-up. This refers to the actual usage of electronic media by citizens and stakeholders. In many cases the measurement of the actual take-up could also be evidence-based and collected automatically.

## Conclusion

The objective of this paper was to identify indicators at the urban level, which provide a first assessment of success factors in a country for the implementation of e-participation to predict the potential of its application in developing countries. The discussion suggests that a success indicator must take into account the general readiness of a political system to take citizen opinion into account, freedom of expression, and the technical capabilities.

Unfortunately the examined urban data and indices are unsuitable as they do not refer to urban e-governance and e-participation. Consequently, the e-government indices of the United Nations and of Freedom House, as well as the EIU Democracy Index have been analysed to evaluate their capabilities to provide such a forecast. They provide the best approximation for a specific country, despite their being at the national level.

The E-Participation Index has been found to be quite low in developing countries and on a worldwide basis. This means it is the least developed domain of e-government. The democracy indicators show a similar picture.

The ranking of the United Nations E-Participation Index does not fully allow for forecast of the potential success of an e-participation project. The main reason is that the indices of this index measure mainly technical sophistication and availability of government online services, and not political readiness. For an assessment of the potential success, a combined set of indices consisting of the E-Participation Index and other indices such as that of the EIU and the Freedom House assessment are required. Additionally, the actual e-participation projects implemented should be involved in the United Nations survey and considered in the calculation of the E-Participation Index.

Figure 6. Principles of Indicator Collection



## References

- Head count rate (CBN). (2005). Von Bangladesh Bureau of Statistics: [http://www.bbs.gov.bd/RptHIES6\\_2.aspx?page=/PageReportLists.aspx?PARENTKEY=67](http://www.bbs.gov.bd/RptHIES6_2.aspx?page=/PageReportLists.aspx?PARENTKEY=67) abgerufen
- (2007). e-Governance Horizon Scan report, an assesment study of e-Governance in Bangladesh. Access to Information (A2I) programme.
- BANBEIS. (2012). Von Bangladesh Bureau of Educational Information and Statistics: [http://www.banbeis.gov.bd/webnew/index.php?option=com\\_content&view=article&id=316&Itemid=171](http://www.banbeis.gov.bd/webnew/index.php?option=com_content&view=article&id=316&Itemid=171) abgerufen
- (2012). Democracy Index 2012. Democracy at a Stillstand. Economist Intelligence Unit.
- (2012). United Nations E-Government Survey 2012. E-Government for People. New York: United Nations.
- BTRC. (April 2013). Von Bangladesh Telecommunication Regulatory Commission : <http://www.btrc.gov.bd/content/mobile-phone-subscribers-bangladesh-april-2013> abgerufen
- Composition of macro geographical (continental) regions, geographical sub-regions, and selected economic and other groupings. (2013, 10 31). Retrieved 07 03, 2014, from United Nations Statistics Division: <http://unstats.un.org/unsd/methods/m49/m49regin.htm#ftnc>
- (2013). Human Development Report 2013. The Rise of the South: Human Progress in a Diverse World. New York: United Nations Development Programme.
- (2013). Worldwide Governance Indicators, Country data report for Bangladesh, 1996-2013. The World Bank. Von <http://info.worldbank.org/governance/wgi/pdf/c20.pdf> abgerufen
- Bangladesh National Portal Launched, Milestone to Achieve Vision 2021. (23. June 2014). Von Access to Information (a2i) Programme: <http://a2i.pmo.gov.bd/content/bangladesh-national-portal-launched-milestone-achieve-vision-2021> abgerufen
- BTRC. (April 2014). Von Bangladesh Telecommunication Regulatory Commission: <http://www.btrc.gov.bd/content/mobile-phone-subscribers-bangladesh-april-2014> abgerufen
- Childonline. (13. September 2014). Von <http://www.childlineindia.org/> abgerufen
- Failed States Index 2013. (2014, 06 22). Retrieved from <http://fp.statesindex.org/rankings-2013-sortable>

- Krishi call centre. (June 2014). Von Practical actions: <http://practicalaction.org/krishi-call-centre-bangladesh> abgerufen
- MSCI. (2014, 07 03). Retrieved from MSCI Emerging Markets Indexes.
- Newly Industrialized Countries. (04. 07 2014). Von Wikipedia: [http://en.wikipedia.org/wiki/Newly\\_industrialized\\_country](http://en.wikipedia.org/wiki/Newly_industrialized_country) abgerufen
- Power sector updates. (22. May 2014). Von Ministry of Power, Energy and Mineral resources: <http://www.powerdivision.gov.bd/user/brec/85/85> abgerufen
- UNESCO. (20. 06 2014). Von [http://portal.unesco.org/ci/en/ev.php-URL\\_ID=3038&URL\\_DO=DO\\_TOPIC&URL\\_SECTION=201.html](http://portal.unesco.org/ci/en/ev.php-URL_ID=3038&URL_DO=DO_TOPIC&URL_SECTION=201.html) abgerufen
- (2014). United Nations e-Government Survey 2014. E-Government for the Future we want. New York: United Nations.
- Access to information (a2i) programme. (kein Datum). Von Access to information (a2i) programme: <http://a2i.pmo.gov.bd/> abgerufen
- Ahmed Imran, S. G. (2010). Uncovering the Hidden issues in e-Government adoption in a least Developed Country:the Case of Bangladesh. *Journal of Global Information Management*, 18(2) (April-June ), 30-56.
- Bodiroži , M. (2013). System 48 in Indjija, Serbia. ECA Sustainable Cities Regional Dissemination Workshop. Skopje. Abgerufen am 10. July 2014 von [http://i2ud.org/wp-content/uploads/2013/03/Indjija\\_Sistem48\\_HolidayInn\\_Skopje.pdf](http://i2ud.org/wp-content/uploads/2013/03/Indjija_Sistem48_HolidayInn_Skopje.pdf)
- Charru Malhotra, V. C. (2011). Citizen-centricity for e-Governance initiatives in Rural Areas. Indian Institute of Public Administration. Von <http://www.unapcict.org/ecohub/citizen-centricity-for-e-governance-initiatives-in-rural-areas> abgerufen
- COMESA, E-Government Portal. (n.d.). Retrieved from <http://egov.comesa.int/index.php/e-government-resouces/31>.
- Demir, E., & Mehmedbaši , D. (2013). Sarajevo Social Accountability City Note. ECA Sustainable Cities Regional Dissemination Workshop. Skopje. Abgerufen am 10. July 2014 von <http://i2ud.org/wp-content/uploads/2013/03/Presentation-Sarajevo.pdf>
- Developing Countries. (n.d.). Retrieved 07 03, 2014, from Wikipedia: [http://en.wikipedia.org/wiki/Developing\\_country](http://en.wikipedia.org/wiki/Developing_country)
- Freedom House. (n.d.). Retrieved 06 24, 2014, from <http://freedomhouse.org/about-us#.U6lyjE2KcPo>
- Freedom House Regions. (n.d.). Retrieved 06 21, 2014, from <http://www.freedomhouse.org/regions#.U6qy302KAmc>.
- Fung, A., Gilman, H., & Shkabatur, J. (2010). Impact case studies from middle income and developing countries: New Technologies. Open Society Foundation, Transparency & Accountability Initiative, London. Abgerufen am 10. July 2014 von [http://www.transparency-initiative.org/wp-content/uploads/2011/05/impact\\_case\\_studies\\_final1.pdf](http://www.transparency-initiative.org/wp-content/uploads/2011/05/impact_case_studies_final1.pdf).
- Gali , N., & Predojevic, N. (2013). Banja Luka City Note. ECA Sustainable Cities Regional Dissemination Workshop. Skopje. Abgerufen am 10. July 2014 von <http://i2ud.org/wp-content/uploads/2013/03/Banja-Luka-City-Note.pdf>
- Halil Dundar, T. B. (2014). Student Learning in South Asia, Challenges, Opportunities and Policy Priorities. Washington DC: The World Bank.
- I2UD & Co-PLAN. (2013). Final Reflections. Social Sustainability Assessment. ECA Sustainable Cities Initiative. Abgerufen am 27. June 2014 von <http://i2ud.org/wp-content/uploads/2013/10/ECA-final-project-brief.pdf>
- Islam, G. Z. (2009). E-Governance Implementation in Metropolitan and Rural Areas of Bangladesh: An Illustrative Prototype. *International Technology Management Review*, 2 Number 1 (October), 33-49.
- Kekic, L. (2012). The Economist Intelligence Unit's Index of Democracy. *The World in 2007*. 2007: The Economist Intelligence Unit.
- Macintosh, A. (2004). Characterizing e-participation in Policy Making. Proceedings of the Thirty-Seventh annual Hawaii International Conference on System Sciences (HICSS-37). Hawaii.
- Macintosh, A. (2004). Using Information and Communication Technologies to Enhance Citizen Engagement in the Policy Process. OECD Publishing.
- Malik, K. (2013). Human Development Report 2013. The Rise of the South. Human Progress in a Diverse World. New York: United Nations Development Programme.
- Md. Zohurul Islam, R. K. (2012). Preparation of E-Government in Bangladesh:An Exploratory Analysis. *JU Journal of Information Technology (JIT)*, 1(June), 19-26. Von [www.juniv.edu/jujit/files/2012/09/4.pdf](http://www.juniv.edu/jujit/files/2012/09/4.pdf) abgerufen
- Morgan, C. (2013). ICTs and Social Inclusion. ECA Sustainable Cities Regional Dissemination Workshop. Skopje. Abgerufen am 10. July 2014 von <http://i2ud.org/wp-content/uploads/2013/03/ICTs-and-Social-Inclusion-cm-i2ud.pdf>
- Puddington, A. (2014). Freedom House. Von Freedom in the World: <http://freedomhouse.org/sites/default/files/Freedom%20in%20the%20World%202014%20Booklet.pdf> abgerufen
- Rajanish Dass, A. B. (2011). Status of Common Service Center Program in India:Issues, Challenges and Emerging Practices for Rollout. INDIAN INSTITUTE OF MANAGEMENT, W.P. No. 2011-02-03. Von <http://www.iimahd.ernet.in/assets/snippets/workingpaperpdf/2011-02-03RajanishDass.pdf> abgerufen
- Raúl Zambrano, R. K. (2013). From Connectivity to Service Delivery: Case studies in e-governance. New York: United Nations Development Programme. Von <http://www.undp.org/content/dam/undp/library/Democratic%20Governance/Access%20to%20Information%20and%20E-governance/From%20Connectivity%20to%20Service%20Delivery%20-%20Case%20Studies%20in%20E-Governance.pdf> abgerufen
- Rohit Prasad, R. S. (2012). Critique of the Common Service Centre Scheme. *Economic & Political Weekly*, xlvi (6), 18-23. Von <http://dspace.md.ac.in/dspace/bitstream/123456789/636/1/Critique+of+the+common+service+centre+scheme.pdf> abgerufen
- Saxena, K. (2005). Towards excellence in e-governance. *International Journal of Public Sector Management*, 18(6), 498-513.
- Slovak Governance Institute. (2014). Statistiky. Abgerufen am 10. July 2014 von <http://www.odkazprestarostu.sk/>
- The World Bank. (26. May 2014). Youth Unemployment in South East Europe: Averting a Lost Generation. Abgerufen am 10. July 2014 von World Bank News: <http://www.worldbank.org/en/news/feature/2014/05/26/youth-unemployment-southeast-europe-averting-lost-generation>
- UNDP. (2011). Governance Principles, Institutional Capacity and Quality. In B. f. Policy, Towards Human Resilience: Sustaining MDG Progress in an Age of Economic Uncertainty. New York: United Nations.
- UN-Habitat. (2013). State of the World's Cities 2012/2013. Prosperity of Cities. New York: Rothledge.
- UN-Habitat. (2014). The State of African Cities 2014. Re-imagining sustainable urban transitions. Nairobi: UN-Habitat.
- United Nations Statistics Division. (n.d.). Retrieved 07 03, 2014, from Standard Country or Area Codes for Statistical Use: <http://unstats.un.org/unsd/methods/m49/m49.htm>
- United Nations. Department of Economic and social Affairs. (n.d.). Retrieved 07 24, 2014, from <http://esa.un.org/unpd/wup/CD-ROM/Default.aspx>





# E-GOVERNANCE AND URBAN POLICY DESIGN IN DEVELOPING COUNTRIES

Governance is about the processes by which public policy decisions are made and implemented. ICT can become a catalyst to improve governance in towns and cities and help increase the levels of participation, efficiency and accountability in public urban policies, provided that the tools are appropriately used, accessible and affordable. This book examines how ICT enabled governance is applied to urban policy design and highlights case studies, tools, methodologies, all reflecting current challenges and potential for the use of ICT in governance processes in cities.

UN-Habitat coordinated this publication to bring the developing countries and the urban policy design perspectives in the framework of a global research of the Future Policy Modeling research project (FUPOL <http://www.fupol.eu/>) that aims to create a comprehensive information communication technology model to support public policy design and implementation.

This publication was made possible thanks to the support of the European Union Seventh Framework Programme for research, technological development and demonstration.

HS Number: HS/054/15E  
ISBN Number: (Volume) 978-92-1-132673-4

Local Government and Decentralization Unit  
Urban Legislation Land and Governance Branch  
UN-Habitat  
E-mail: [governance@unhabitat.org](mailto:governance@unhabitat.org)

United Nations Human Settlements Programme (UN-Habitat)  
P.O.Box 30030, 00100 Nairobi GPO KENYA  
Tel: +254-20-7623120 (Central Office)  
[infohabitat@unhabitat.org](mailto:infohabitat@unhabitat.org)



**UN HABITAT**

[www.unhabitat.org](http://www.unhabitat.org)